



PN25 Brass Gate Valve

Features

- Screwed BSP Taper
- Full Bore
- BS5154
- Kite Marked KM553179

Pressure / Temperature

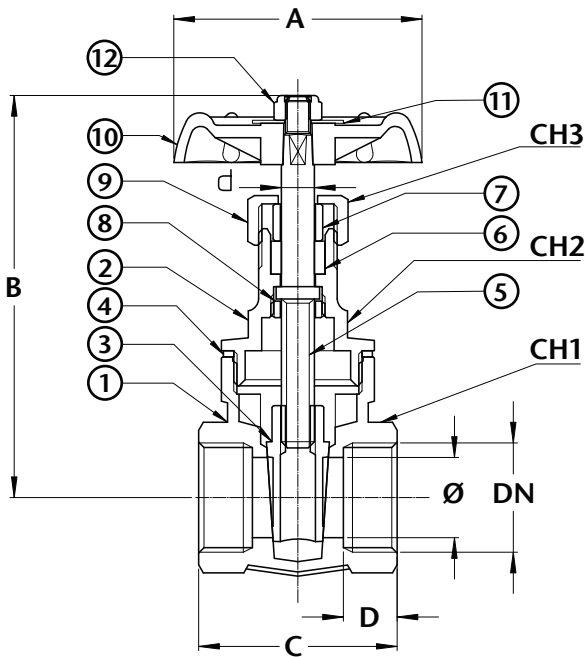
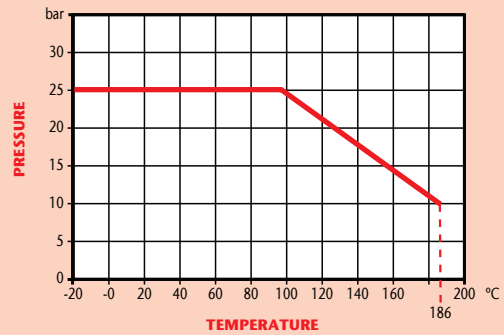

DN	1/2"	3/4"	1"	1 1/4"	1 1/2"	2"	2 1/2"	3"	4"
ø	13	19.4	26	32	38.5	50.4	64	77	102
A	55	60	65	75	80	90	120	140	175
B	80	97	108	122	142	166	212	248	297
C	44	48	55	61	65	71	92	98	107
D	12	13	15.5	16.5	18	19	24	26	28
CH1	27	33	40	50	56	69	85	100	130
CH2	22	24	26	32	42	52	60	80	110
CH3	19	21	21	25	25	29	33	37	45
d	8	8	9	10	11	12	16	17	19
Kgs	0.26	0.39	0.53	0.81	1.15	1.80	3.52	5.33	8.96

N.	Part Name	Materials
1	Body	Brass
2	Bonnet	Brass
3	Wedge	Brass
4	Packing	Graphite
5	Stem	Brass
6	Gasket	PTFE
7	Gland Screw	Brass
8	Cap	Brass
9	Nut	Brass
10	Handwheel	Steel
11	Plate	Aluminium
12	Self-Locking Nut	Steel

Technical Data

Max Pressure	25 Bar
Working Temperature	-10°C to +186°C

Dimensions in mm

This data sheet is designed as a guide and should not be regarded as wholly accurate in every detail. We reserve the right to amend the specification of any product without notice.