

GAS FLANGIATA - IVR 82-83



Valvola a sfera per gas flangiata PN 16. Corpo in ghisa GJS400.
Flangetta ISO 5211.

Vanne à sphère pour gaz à brides, PN 16. Corp en fonte GJS400.
Platine ISO 5211.

Full bore ball valve for gas flanged PN 16 in cast iron GJS400.
With ISO 5211 top for actuator.

Flansch-Kugelventil PN 16 für gas. Körper aus Gusseisen GJS400.
Mit ISO 5211 Flansch für motorisieren.



IMPIEGHI: Le valvole a sfera serie IVR 82-83 sono adatte per impianti di distribuzione gas a media e bassa pressione e idrocarburi.

APPLICATIONS: The IVR 82-83 series are suitable for medium and low pressure gas distribution plants and hydrocarbons.

ART. 83 - Come IVR 82 ma con sfera e asta in acciaio inox AISI 304
ART. 83 - Like IVR 82 but with stainless steel AISI 304 stem and ball



N. N.	DENOMINAZIONE PART NAME	MATERIALE MATERIAL	TRATTAMENTO TREATMENT
1	Corpo - Body	Ghisa GJS400 - Cast iron GJS400	Verniciato - Painted
2	Flangia - Flange	Ghisa GJS400 - Cast iron GJS400	Verniciato - Painted
3	Seggio - Seat	PTFE	
4	Sfera - Ball	Ottone - Brass G-CuZ38Pb2-UNI 5035/62	Cromata - Chrome plated
5	Rondella - Seal	PTFE	
6	Asta - Stem	AVP - 9SMnPb36	
7	O-ring - O-ring	FP	
8	O-ring - O-ring	FP	
9	Premistoppa - Packing nut	Ottone - Brass CW 614N - UNI EN 12164/98	
10	Maniglia - Handle	Acciaio - Steel	Rivest. PVC - Plastic coated
11	Cappuccio - Cap	Ottone - Brass CW 614N - UNI EN 12164/98	Nichelato - Nickel plated
12	Vite - Screw	Acciaio - Steel	Zincato - Zinc plated
13	Vite - Screw	Acciaio - Steel	Zincato - Zinc plated
14	O-ring - O-ring	FP	
15	Vite a brugola - Screw	Acciaio - Steel	Zincato - Zinc plated

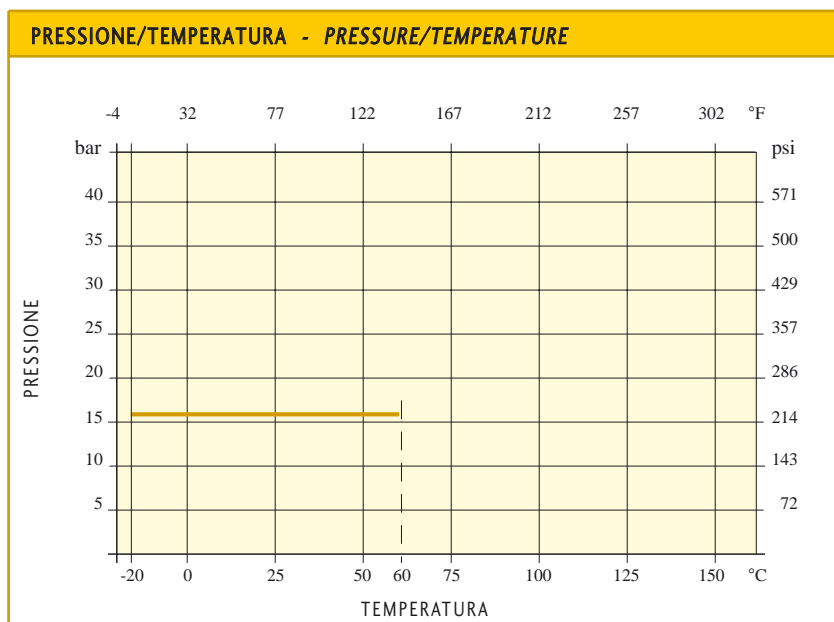
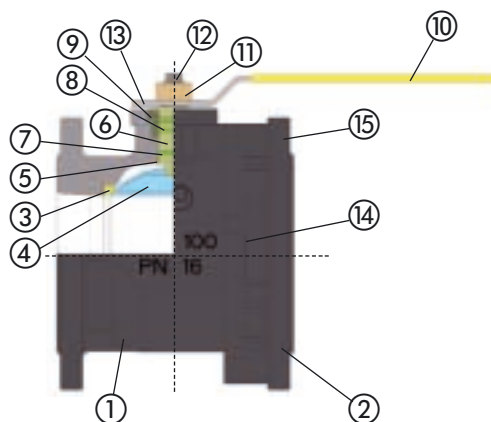

DATI TECNICI - TECHNICAL DATA

Pressione di esercizio Working pressure	16 bar
Temperatura di esercizio Working temperature	-20°C + 60°C
Estremità flangiate Flanged ends	UNI - EN 1092/03
Asta antiscoppio Anti blow-out stem	



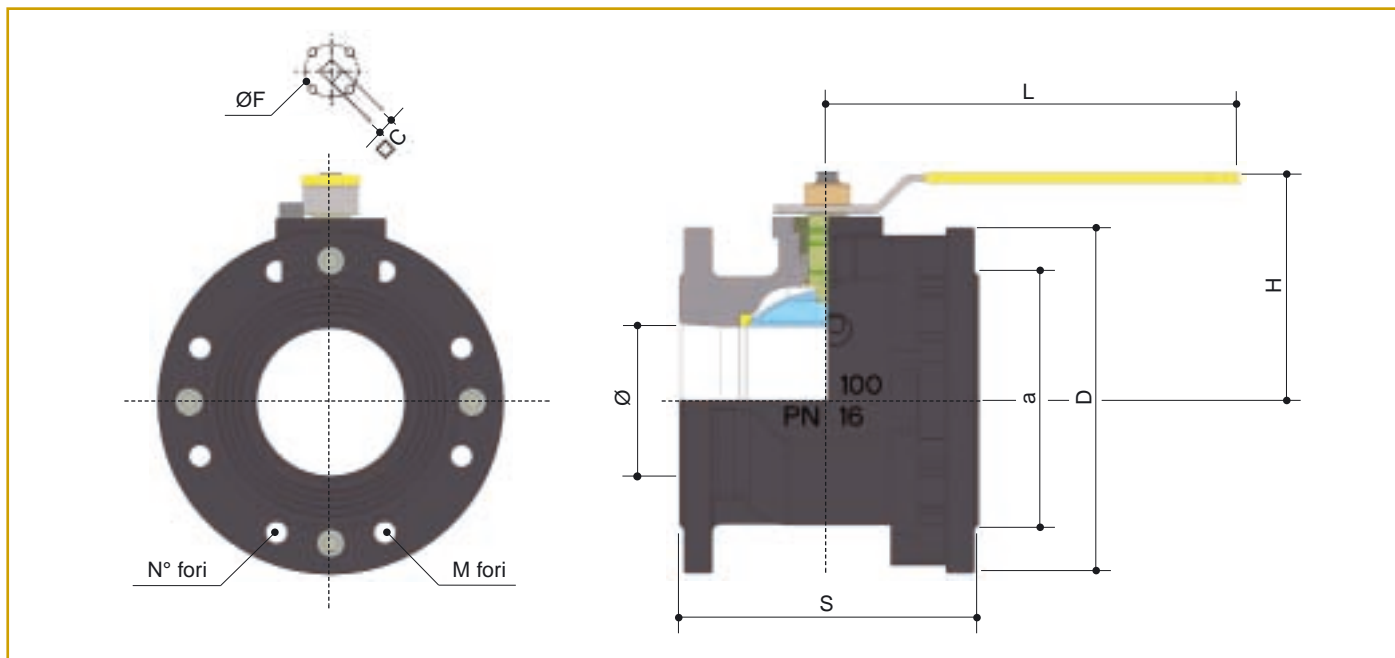

DN	20	25	32	40	50	65	80	100	125	150
Ø	20	25	32	40	50	61	74	95	120	145
S	120	125	130	140	150	170	180	190	200	210
H	73	77	82	92	99	121	130	144	185	204
L	200	200	200	240	240	260	260	260	450	450
D	105	115	140	150	165	185	200	220	250	285
a	75	85	100	110	125	145	160	180	210	240
N° fori	4	4	4	4	4	4	8	8	8	8
M fori	M12	M12	M16	M16	M16	M16	M16	M16	M16	M20
Fl.ISO	F04	F04	F04	F05	F05	F07	F07	F07	F10	F10
Ø F	42	42	42	50	50	70	70	70	102	102
□C	9	9	9	14	14	17	17	17	22	22

Dimensioni in mm - Dimensions in mm

DIAGR. PERDITE DI CARICO - FLOW AND PRESSURE DROP

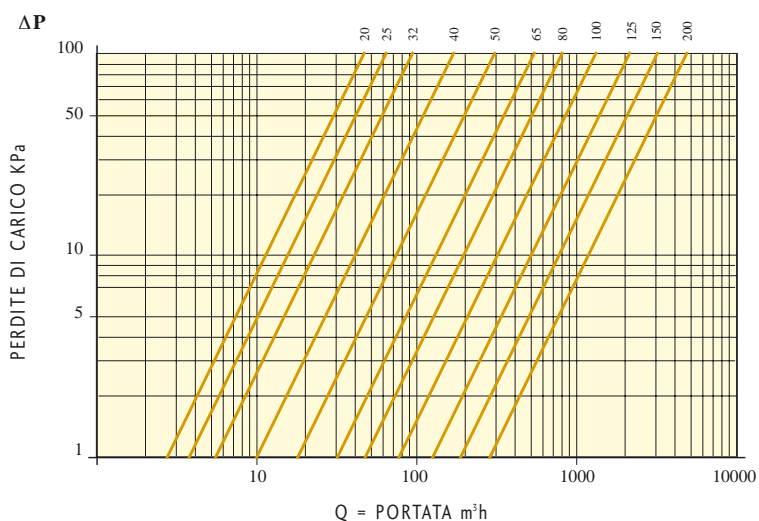

COEFFICIENTE KW - KW FACTOR

DN 20	45
DN 25	60
DN 32	100
DN 40	170
DN 50	265
DN 65	510
DN 80	790
DN 100	1230
DN 125	1900
DN 150	2900
DN 200	5700