



PN32 Brass Ball Valve

Features

- Screwed BSP Parallel
- Anti-Blow-Out Stem
- PTFE Seat
- Full Bore
- WRAS Approved

Pressure / Temperature

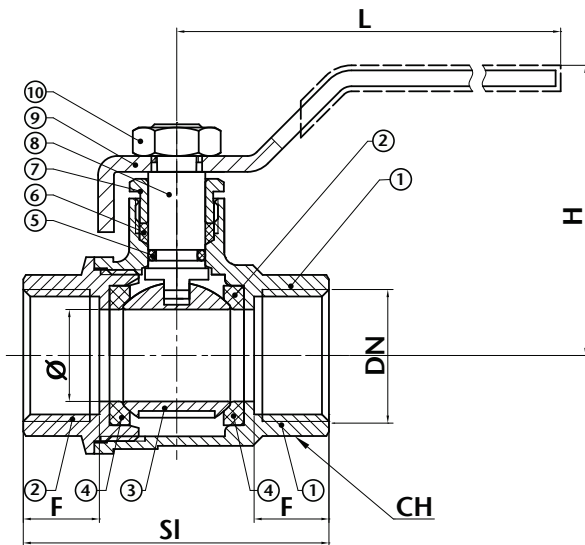
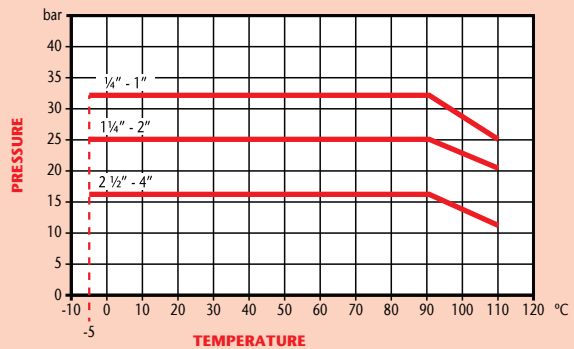

DN	1/4"	3/8"	1/2"	3/4"	1"	1 1/4"	1 1/2"	2"	2 1/2"	3"	4"
Ø	10.5	10.5	15	20	25	32	40	50	62	75	95
F	9.5	10	10	11	13	15.5	16.5	18	23.5	25	27
SI	41.5	43.5	55.2	57.5	68.5	90	91.5	122	131.5	151	182
H	39.5	39.5	42.5	46	69	69	83.5	83.5	107	116.5	152
L	80	80	92	92	105	105	150	150	225	225	250
CH	17.5	20.5	25	31	38	47	54	66	84	96	123
Kgs	0.12	0.12	0.18	0.27	0.42	0.71	0.93	1.52	2.90	3.82	7.03

Technical Data

Max Pressure	1/4"-1"	32 Bar
	1 1/4"-2"	25 Bar
	2 1/2"-4"	16 Bar
Working Temperature	-5°C to +110°C	

N.	Part Name	Materials
1	Body	Brass/Nickel Plated
2	Body End	Brass/Nickel Plated
3	Ball	Brass/Chrome Plated
4	Seat	PTFE
5	'O' Ring	NBR
6	Stem Packing	PTFE
7	Lock Nut	Brass
8	Stem	Brass
9	Lever	Steel/Zinc Plated
10	Nut	Steel/Zinc Plated

Dimensions in mm

This data sheet is designed as a guide and should not be regarded as wholly accurate in every detail. We reserve the right to amend the specification of any product without notice.