

PN82 Carbon Steel 3 Piece Ball Valve

Features

- Screwed BSP Taper
- RPTFE (15%) Seats
- PTFE Seals
- Full Bore
- PN82 Rated
- Locking Device



Pressure / Temperature

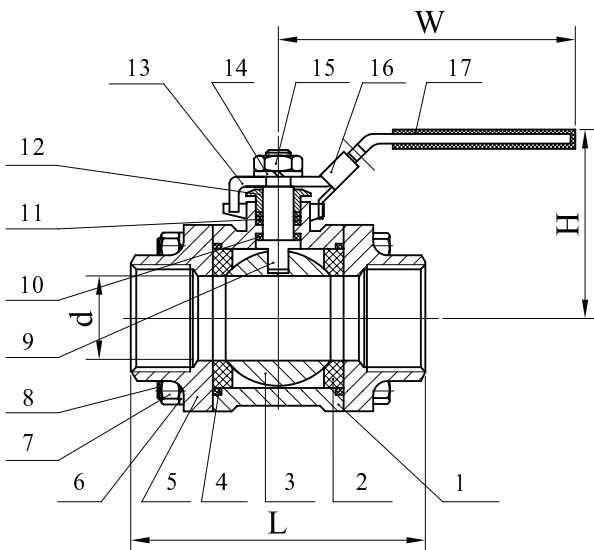
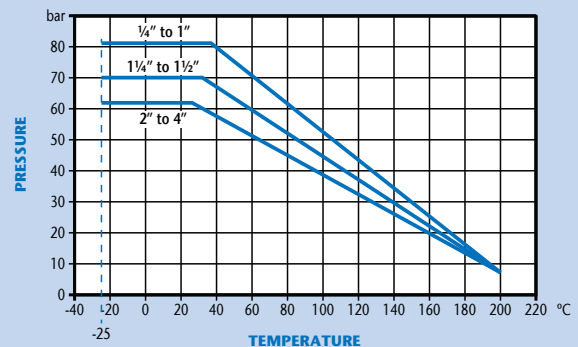

DN	1/4"	3/8"	1/2"	3/4"	1"	1 1/4"	1 1/2"	2"	2 1/2"	3"
d	11	12.5	15	20	25	32	40	50	65	80
L	50	60	75	80	90	110	120	140	185	205
H	51	51	53	60	75	80	88	95	121	135
W	105	105	118	118	150	150	182	182	254	254
Torque	4	4	5	8	10	14	18	25	48	75
Kgs	0.40	0.42	0.45	0.73	1.04	1.65	2.43	3.52	7.14	11.85

N.	Part Name	Material
1	Body	Carbon Steel
2	Ball Seat	R-PTFE (15%)
3	Ball	Stainless Steel 316
4	Body Gasket	PTFE
5	Cap	Carbon Steel
6	Spring Washer	Stainless Steel 304
7	Nut	Stainless Steel 304
8	Bolt	Stainless Steel 304
9	Stem	Stainless Steel 316
10	Thrust Washer	PTFE
11	Stem Packing	PTFE
12	Gland Nut	Stainless Steel 304
13	Handle	Stainless Steel 304
14	Spring Washer	Stainless Steel 304
15	Nut	Stainless Steel 304
16	Lock Device	Stainless Steel 304
17	Handle Cover	Plastic

Technical Data

Max Pressure 82 Bar (1/4"-1") 69 Bar (1 1/4"-1 1/2") 62 Bar (2"-4")
 Working Temperature -25°C to +200°C

Dimensions in mm

This data sheet is designed as a guide and should not be regarded as wholly accurate in every detail. We reserve the right to amend the specification of any product without notice.