

ANSI 150 Stainless Steel Flanged Ball Valve

Features

- Flanged ANSI 150
- Class 150 Rated
- RPTFE (15%) Seats
- PTFE/Viton Seals
- Full Bore
- ISO 5211 Direct Mount

Pressure / Temperature

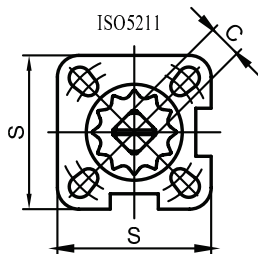
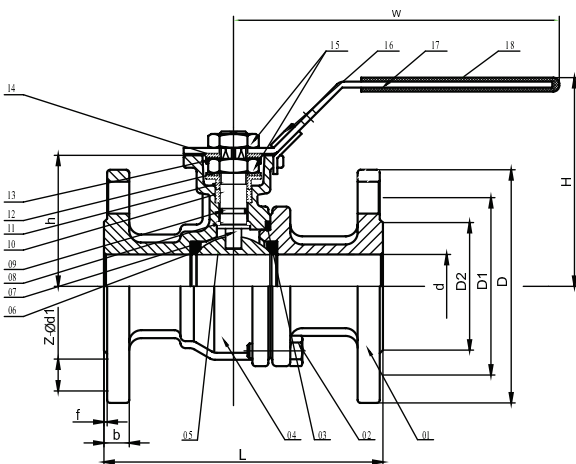
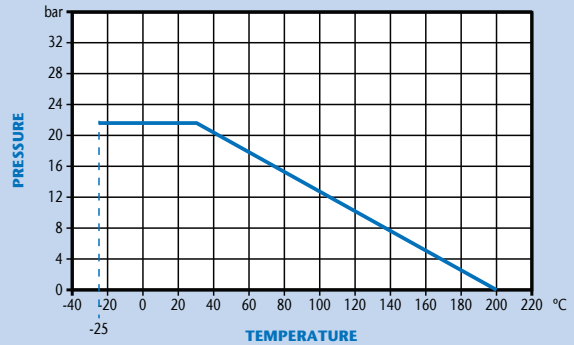

* Torque - Raw torque with no safety added

Technical Data

Max Pressure 22 bar
Working Temperature -25°C to +200°C

Dimensions in mm

This data sheet is designed as a guide and should not be regarded as wholly accurate in every detail. We reserve the right to amend the specification of any product without notice.

DN	1/2"	3/4"	1"	1 1/4"	1 1/2"	2"	2 1/2"	3"	4"
d	15	20	25	32	38	50	65	76	94
L	108	117	127	140	165	178	190	203	229
D	89	98	108	117	127	152	178	190	229
D1	60.5	70	79.5	89	98.5	120.5	139.5	152.5	190.5
D2	35	43	51	64	73	92	105	127	157
b	10	11	11	13	15	16	18	19	24
f	2	2	2	2	2	2	2	2	2
H	80	85	95	108	114	124	148	158	191
W	140	140	160	160	185	185	230	230	230
C	9	9	11	11	14	14	17	17	17
ISO5211	F03/F04	F03/F04	F04/F05	F04/F05	F05/F07	F05/F07	F07/F010	F07/F010	F07/F010
Z-Ød1	4-Ø16	4-Ø16	4-Ø16	4-Ø16	4-Ø16	4-Ø19	4-Ø19	4-Ø19	8-Ø19
h	48.3	53	58.5	71	76	84.5	101.5	111.5	141
s	42.6	42.6	50	50	64.5	64.5	93.6	93.6	93.6
Torque	5	8	10	14	18	25	48	75	110
Kgs	1.35	1.85	2.60	3.58	5.40	7.95	13.5	17.3	29.5

N.	Part Name	Material
1	Cap	CF8M
2	Bolt	Stainless Steel 304
3	Body Gasket	PTFE
4	Body	CF8M
5	Ball	Stainless Steel 316
6	Ball Seat	R-PTFE (15%)
7	Stem	Stainless Steel 316
8	Thrust Washer	PTFE
9	O-Ring	Viton
10	Stem Packing	PTFE
11	Packing Ring	Stainless Steel 304
12	Belleville Washer	Stainless Steel 301
13	Nut Stopper	Stainless Steel 304
14	Plate Washer	Stainless Steel 304
15	Nut	Stainless Steel 304
16	Lock Device	Stainless Steel 304
17	Handle	Stainless Steel 304
18	Plastic Cover	Plastic
19	Stop Pin	Stainless Steel 304