

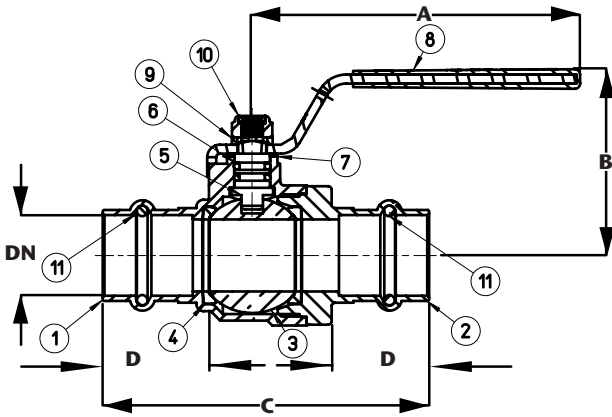

PN16 DZR Brass Ball Valve

Features

- 'M' Press Ends
- Full Bore
- DZR Brass Body
- PTFE Seats
- EPDM 'O' Rings
- Pre Press Leak Detection



NB: It is recommended you use a 'm' press sling to press sizes 42mm and 54mm

Sizes 15mm to 35mm can be pressed with both 'm' and 'v' press jaws

Technical Data	
Max Pressure	16 Bar
Working Temperature	-10°C to +120°C

Dimensions in mm

This data sheet is designed as a guide and should not be regarded as wholly accurate in every detail. We reserve the right to amend the specification of any product without notice.

Pressure / Temperature

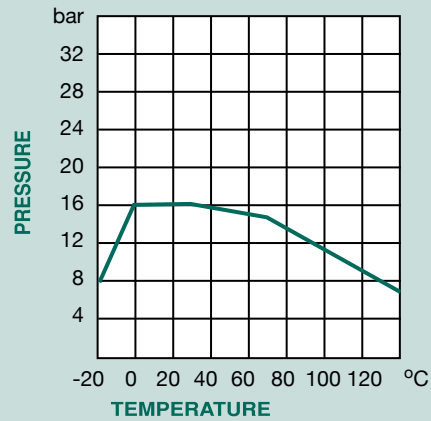

DN	15	22	28	35	42	54
A	90	90	110	110	150	150
B	47	52	56.5	65	80.8	88.7
C	78	90.5	99	107	132.5	154.5
D	22	25	27	27	32	33
Kgs	0.19	0.31	0.48	0.72	1.17	1.75

N.	Part Name	Materials
1	Body	DZR Brass
2	Screwed End	DZR Brass
3	Ball	Brass Chrome Plated
4	Ball Gaskets	PTFE
5	Stem	Brass
6	O-Ring	HNBR
7	Anti-Friction Ring	PTFE
8	Handle	Steel
9	Washer	Brass
10	Self-Locking Nut	Steel
11	O-Ring	EPDM 70 PEROX