

PN16 Cast Iron Gate Valve

Features

- Flange Mounting PN16 Only
- BS EN 558-1 Series 14
- DIN 3352F4



Pressure/Temperature

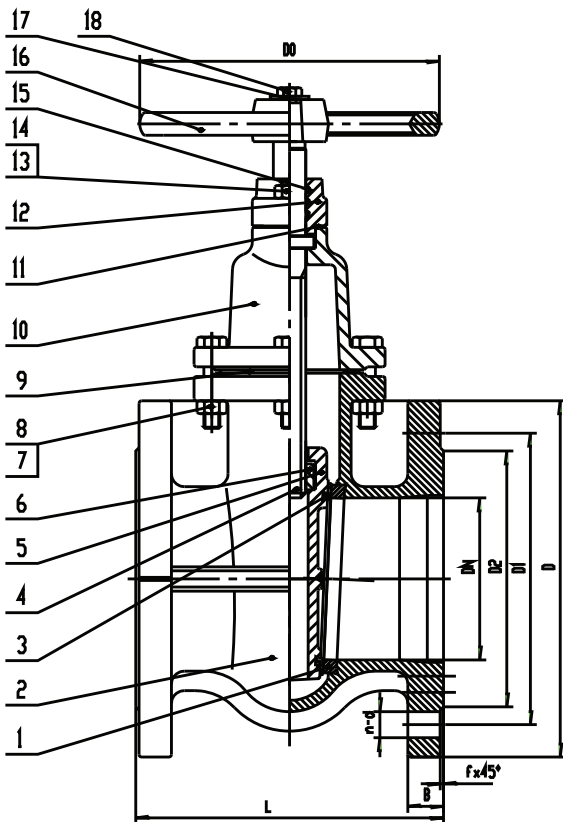
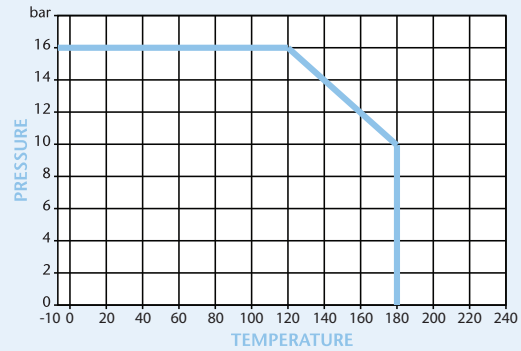

Technical Data

Pressure 16 Bar

Working Temperature -10°C to +180°C

Dimensions in mm

This data sheet is designed as a guide and should not be regarded as wholly accurate in every detail. We reserve the right to amend the specification of any product without notice.

DN	50	65	80	100	125	150	200	250	300
L	150	170	180	190	200	210	230	250	270
D	165	185	200	220	250	285	340	405	460
D1	125	145	160	180	210	240	295	355	410
D2	102	124	140	158	188	212	268	320	378
B	16	16	17	17	18	20	21	23	24
f	2	2	2	2	3	3	3	3	4
n-d	4-19	4-19	8-19	8-19	8-19	8-23	12-23	12-28	12-28
D0	130	130	150	185	185	195	225	245	285
Kgs	10.8	12.8	16.6	22.8	32.1	42.9	71.3	98	145

N.	Part Name	Materials
1	Body Seat Ring	Cast Brass
2	Body	Ductile Iron
3	Wedge Seat Ring	Cast Brass
4	Stem	Stainless Steel
5	Wedge	Ductile Iron
6	Stem Nut	Cast Brass
7	Bolt	Steel
8	Nut	Steel
9	Flange Gasket	Graphite
10	Bonnet	Ductile Iron
11	Stuffing Box Gasket	Graphite
12	Stuffing Box	Ductile Iron
13	Bolt	Steel
14	Nut	Steel
15	O-ring	NBR
16	Handwheel	Cast Iron
17	Washer	Steel
18	Bolt	Steel