



Gunmetal High Discharge Safety Valve

Features

- Screwed BSP Parallel (ISO 228)
- Body Gunmetal
- Suitable for Gases and Liquids
- Fitted with Diaphragm to Protect Spring Housing
- Set Range 0.5 to 16 Bar
- WRAS Approved (½"-1") Other Sizes Under Approval
- ISO 4126-1, PED 2014/68/EU, TRD 421
- Classification - GL, DNV
- ATEX Approval Available at Extra Cost
- 24 Month Warranty
- Test Certificate to EN10204-3.1 Available on Request
- High Capacity Discharge

Typical Applications

- Pressure Vessels
- Mechanical engineering
- Pump protection
- Pressure booster systems water/air-side
- Cooling/Chilling Systems
- Steam and industrial boiler systems

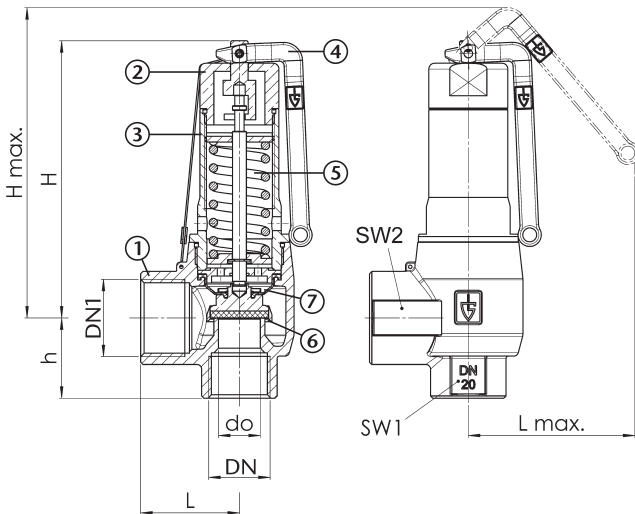

Technical Data

Max Pressure	16 Bar
Working Temperature	EPDM Diaphragm -50°C to +150°C

DN	½"	¾"	1"	1¼"	1½"	2"
DN1	¾"	1"	1¼"	1½"	2"	2½"
L	36	43	47	58	68	80
Lmax	63	78	100	140	150	155
H	90	115	146	192	229	275
h	30	35	37	45	55	65
Hmax	102	133	148	210	252	298
SW1	27	34	41	55	65	80
SW2	34	41	50	60	70	90
do	13	18	23	30	39	48
kg	0.5	0.9	1.6	3.3	5.8	8.9

N.	Part Name	Materials
1	Body	Gunmetal
2	Housing Cap	Brass/Gunmetal
3	Spring Housing	Brass/Gunmetal
4	Lifting Lever	Stainless Steel CF8M
5	Spring	Stainless Steel 302
6	Seat-Seal	PTFE
7	Diaphragm	EPDM

Dimensions in mm

This data sheet is designed as a guide and should not be regarded as wholly accurate in every detail. We reserve the right to amend the specification of any product without notice.

Discharge Capacities

DN Bar	15				20				25			
	Nm ³ /h	kg/h	m ³ /h	kW	Nm ³ /h	kg/h	m ³ /h	kW	Nm ³ /h	kg/h	m ³ /h	kW
0.5	77	58	2.3	37	141	106	4.3	68	208	157	6.6	101
1	114	91	3.0	57	222	177	5.8	112	315	251	8.9	158
2	188	148	4.3	91	366	288	8.3	177	525	413	12.6	254
3	256	200	5.3	121	499	390	10.1	235	729	570	15.4	344
4	327	253	6.1	151	626	486	11.7	290	916	710	17.7	423
5	393	303	6.8	178	754	582	13.1	342	1103	851	19.8	500
6	460	354	7.5	206	882	678	14.3	394	1289	992	21.7	576
7	526	403	8.1	232	1009	773	15.5	445	1476	1130	23.5	650
8	593	453	8.6	258	1137	868	16.5	495	1662	1269	25.1	724
9	660	502	9.1	283	1265	963	17.5	543	1849	1408	26.6	795
10	726	551	9.6	309	1392	1057	18.5	592	2036	1546	28.1	865
11	793	601	10.1	335	1520	1151	19.4	642	2222	1683	29.4	938
12	859	649	10.6	359	1647	1245	20.2	689	2409	1820	30.7	1008
13	926	698	11.0	385	1775	1339	21.1	737	2595	1958	32.0	1078
14	992	748	11.4	408	1903	1434	21.9	783	2782	2097	33.2	1145
15	1059	797	11.8	433	2030	1528	22.6	830	2969	2234	34.4	1213
16	1126	846	12.2	457	2158	1622	23.4	877	3155	2372	35.5	1282

DN Bar	32				40				50			
	Nm ³ /h	kg/h	m ³ /h	kW	Nm ³ /h	kg/h	m ³ /h	kW	Nm ³ /h	kg/h	m ³ /h	kW
0.5	346	261	10.3	167	559	421	16.5	264	867	653	25.7	409
1	505	403	13.9	254	802	641	22.4	403	1241	991	34.8	624
2	816	643	19.7	394	1301	1025	31.7	629	2049	1615	49.2	991
3	1117	873	24.1	526	1783	1393	38.8	840	2806	2194	60.3	1323
4	1429	1108	27.9	660	2283	1770	44.8	1055	3591	2785	69.6	1660
5	1720	1327	31.1	780	2747	2120	50.1	1246	4322	3334	77.8	1960
6	2011	1547	34.1	899	3212	2472	54.8	1436	5053	3888	85.2	2260
7	2302	1762	36.9	1014	3677	2815	59.2	1621	5785	4428	92.0	2549
8	2593	1979	39.4	1129	4142	3162	63.3	1804	6516	4975	98.4	2838
9	2884	2196	41.8	1239	4607	3508	67.2	1980	7248	5519	104.4	3115
10	3175	2411	44.0	1350	5072	3852	70.8	2156	7979	6060	110.0	3392
11	3466	2625	46.2	1463	5537	4195	74.3	2338	8710	6598	115.4	3678
12	3757	2838	48.2	1571	6002	4535	77.6	2511	9442	7134	120.5	3949
13	4048	3054	50.2	1681	6467	4879	80.7	2687	10173	7675	125.4	4226
14	4339	3270	52.1	1785	6932	5224	83.8	2852	10905	8218	130.2	4487
15	4630	3484	53.9	1892	7397	5566	86.7	3022	11636	8756	134.7	4754
16	4921	3699	55.9	1999	7862	5910	89.3	3194	12367	9297	139.1	5024

Seat-Seal/Diaphragm Options

Option	Materials	Type	Working Temp.
PTFE/EPDM	Polytetrafluorethylen/Ethylen-Propylene-Diene (Standard)	Flat seal and moulded diaphragm	-50°C to +150°C
EPDM/EPDM	Ethylen-Propylene-Diene/Ethylen-Propylene-Diene	Flat seal and moulded diaphragm	-50°C to +150°C
PTFE/FKM	Polytetrafluorethylen/Fluorcarbon	Flat seal and moulded diaphragm	-30°C to +200°C
FKM/FKM	Fluorcarbon/Fluorcarbon	Elastomere seals and moulded diaphragm	-20°C to +200°C

Dimensions in mm

This data sheet is designed as a guide and should not be regarded as wholly accurate in every detail. We reserve the right to amend the specification of any product without notice.