



PN82 Stainless Steel 'L' Port Ball Valve

Features

- Screwed BSP Taper
- RPTFE (15%) Seats
- PTFE/Viton Seals
- Reduced Bore
- PN82 Rated
- Locking Device
- ISO 5211 Direct Mount

Pressure / Temperature

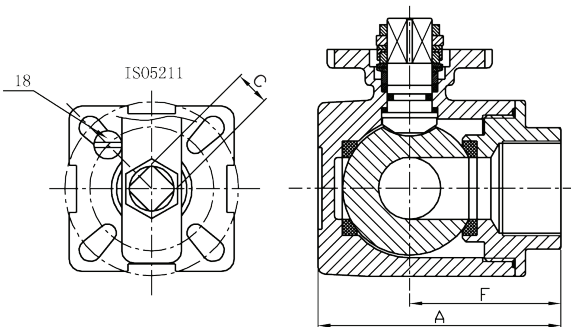
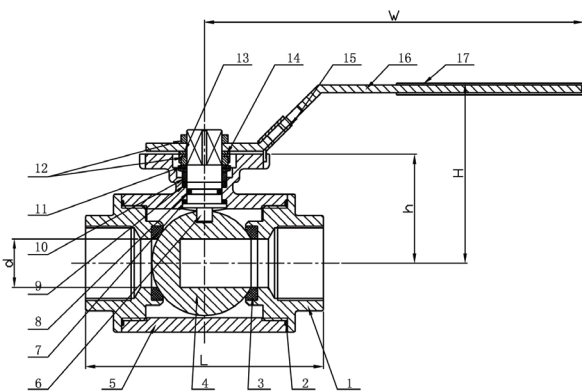
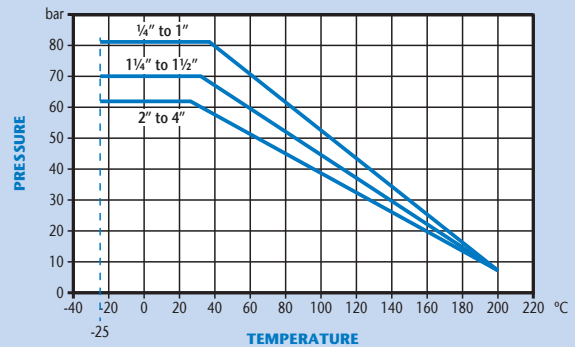

* Torque - Raw torque with no safety added

Technical Data

Max Pressure 82 Bar (1/4"-1") 69 Bar (1 1/4"-1 1/2") 62 Bar (2"-4")
 Working Temperature -25°C to +200°C

DN	1/4"	3/8"	1/2"	3/4"	1"	1 1/4"	1 1/2"	2"	2 1/2"	3"	4"
d	9.5	11	12	15	20	25	32	40	49	60	75
L	75	75	75	85	100	122	131	158	178	202	246
H	66	66	66	72	77	92	96	107	135	147	160
W	130	130	130	161	161	203	203	203	254	254	310
h	36.8	36.8	36.8	41.2	46.5	56	60	70.5	95.5	106	119
F	37.5	37.5	37.5	42.5	50	61	65.5	79	89	101	123
A	57.5	57.5	57.5	65.5	79	97	106.5	129	145	167	203
C	9	9	9	11	11	14	14	14	17	17	17
ISO5211	F03/F04	F03/F04	F03/F04	F04/F05	F04/F05	F05/F07	F05/F07	F05/F07	F07/F010	F07/F010	F07/F010
Torque	8	8	8	9	15	20	30	45	60	90	120
Kgs	0.70	0.67	0.63	0.94	1.39	2.91	3.66	6.31	8.95	13.11	22.10

N.	Part Name	Material
1	Cap	CF8M
2	Gasket	PTFE
3	Ball Seat	R-PTFE (15%)
4	Ball	Stainless Steel 316
5	Body	CF8M
6	Stem	Stainless Steel 316
7	Thrust Washer	PTFE
8	O-Ring	Viton
9	Stem Packing	PTFE
10	Stem Ring	Stainless Steel 316
11	Belleville Washer	Stainless Steel 304(301)
12	Nut	Stainless Steel 304
13	Plate Washer	Stainless Steel 304
14	Nut Stopper	Stainless Steel 304
15	Lock Device	Stainless Steel 304
16	Handle	Stainless Steel 304
17	Handle Sleeve	Plastic
18	Stop Pin	Stainless Steel 304

Dimensions in mm

This data sheet is designed as a guide and should not be regarded as wholly accurate in every detail. We reserve the right to amend the specification of any product without notice.