

AVION

Press Valves

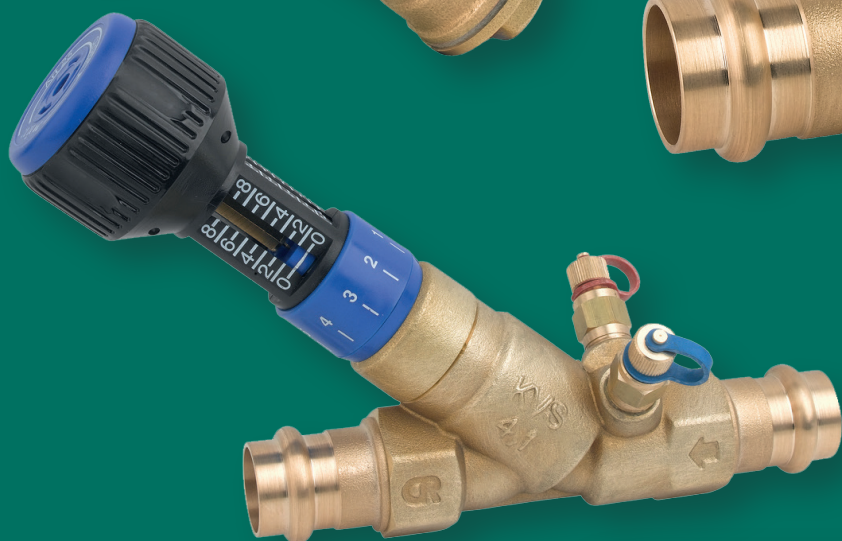

Product information

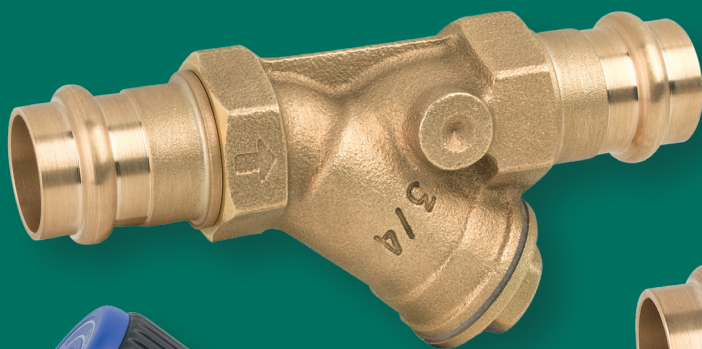
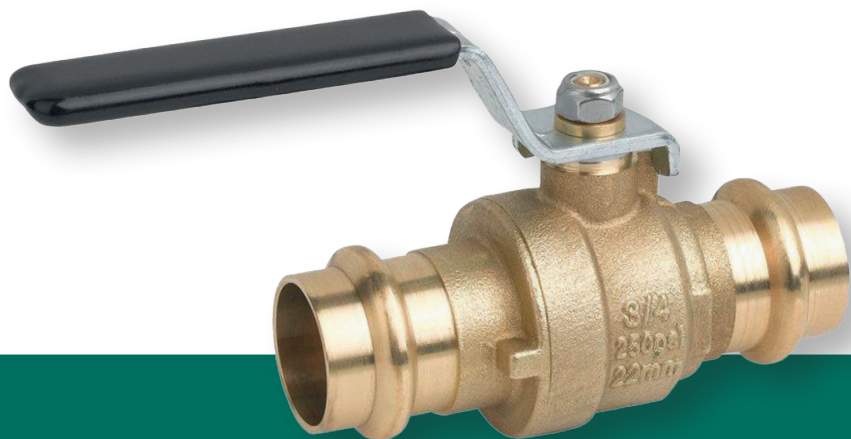

PN16 DZR Press Ball Valve

Features

- Universal M & V Press 15mm to 35mm
- Dedicated M & V Profiles 42mm & 54mm (See diagram)
- Full Bore
- DZR Brass Body
- PTFE Seats
- EPDM 'O' Rings
- Pre-Press Leak Detection
- WRAS Approved

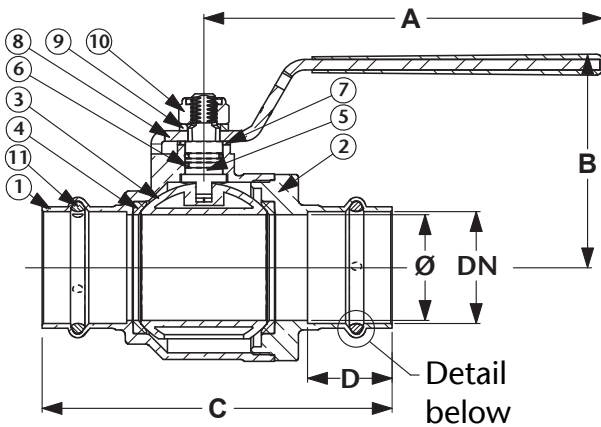
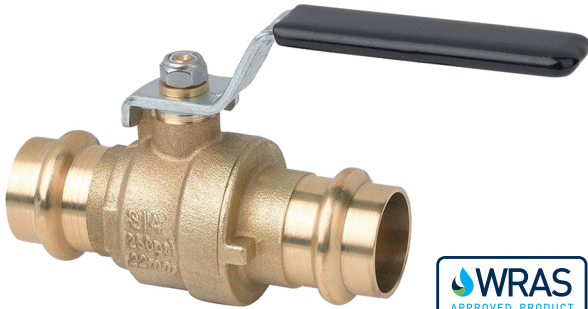

Pressure / Temperature

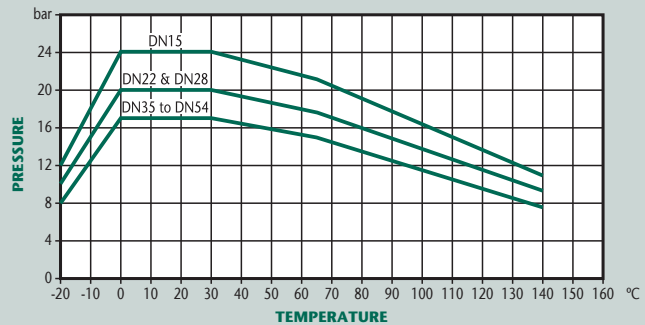

'M' Press (DN42)

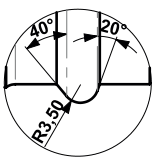

'M' Press (DN54)

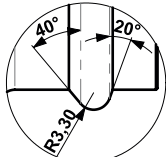

'V' Press (DN42+54)

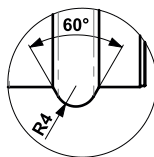

NB: Sizes 15mm to 35mm can be pressed with both 'M' and 'V' press jaws. Always use the appropriate 'M' or 'V' press sling to press sizes 42mm and 54mm

Technical Data

Max Pressure 16 Bar
Working Temperature -20°C to +140°C

Dimensions in mm

This data sheet is designed as a guide and should not be regarded as wholly accurate in every detail. We reserve the right to amend the specification of any product without notice.

| DN | 15 | 22 | 28 | 35 | 42 | 54 |
|-------------|------|------|------|------|------|------|
| A | 90 | 90 | 110 | 110 | 150 | 150 |
| B | 47 | 52 | 57 | 65 | 81 | 89 |
| C (M Press) | 78 | 91 | 99 | 107 | 133 | 155 |
| C (V Press) | 78 | 91 | 99 | 107 | 133 | 163 |
| D (M Press) | 22 | 25 | 27 | 27 | 32 | 33 |
| D (V Press) | 22 | 25 | 27 | 27 | 32 | 37 |
| Kgs | 0.19 | 0.31 | 0.49 | 0.72 | 1.17 | 1.72 |

| N. | Part Name | Materials |
|----|--------------------|---------------------|
| 1 | Body | DZR Brass |
| 2 | Screwed End | DZR Brass |
| 3 | Ball | Brass Chrome Plated |
| 4 | Ball Gaskets | PTFE |
| 5 | Stem | Brass |
| 6 | O-Ring | FKM 70 SH |
| 7 | Anti-Friction Ring | PTFE |
| 8 | Handle | Steel |
| 9 | Washer | Brass |
| 10 | Self-Locking Nut | Steel |
| 11 | O-Ring | EPDM 70 PEROX |



PN16 DZR Balancing Valve

Features

- 'M' Press Ends
- DZR Brass Body
- EPDM 'O' Rings
- Pre Press Leak Detection

Pressure / Temperature

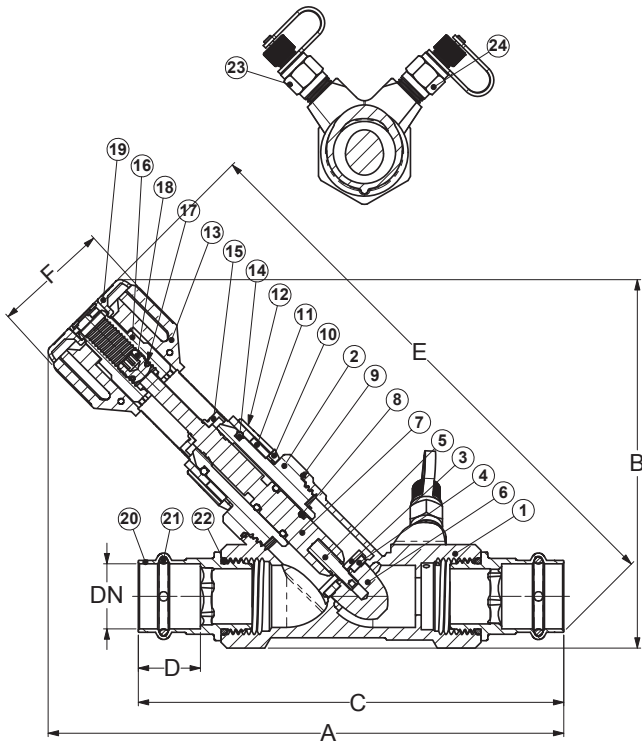
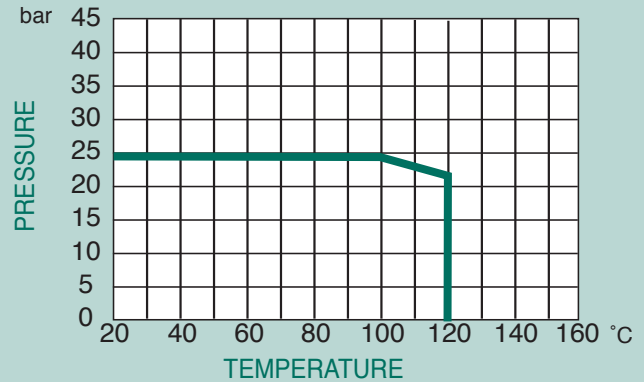

| DN | 15 | 22 | 28 | 35 | 42 | 54 |
|-----|-------|-------|-------|-------|-------|-------|
| A | 192.5 | 218 | 225 | 244.5 | 302.5 | 332.5 |
| B | 126.5 | 147 | 160.5 | 170 | 212.5 | 230 |
| C | 144 | 165 | 185 | 216 | 247.5 | 295 |
| D | 22 | 25 | 27 | 27 | 32 | 37 |
| E | 203 | 238.5 | 247 | 265 | 335 | 363.5 |
| F | 52 | 52 | 52 | 52 | 58 | 58 |
| Kgs | 0.77 | 1.06 | 1.34 | 1.96 | 2.85 | 4.37 |

| N. | Part Name | Materials |
|----|---------------------|---------------|
| 1 | Body | DZR Brass |
| 2 | Bonnet | DZR Brass |
| 3 | Gasket Support | DZR Brass |
| 4 | Gasket | EPDM |
| 5 | Stem for Shutter | DZR Brass |
| 6 | Shutter | DZR Brass |
| 7 | Stem | DZR Brass |
| 8 | O-Ring | EPDM PEROX |
| 9 | O-Ring | EPDM PEROX |
| 10 | Turn Index | Hostaform |
| 11 | Outdistance | Nylon |
| 12 | 1/10 Turn Index | Hostaform |
| 13 | Knob | Hostaform |
| 14 | Pin | Steel |
| 15 | Index | Hostaform |
| 16 | Entrainer | Brass |
| 17 | Stem Gaskets O-Ring | NBR 70SH |
| 18 | Memory | Brass |
| 19 | Cup | Hostaform |
| 20 | Adaptor | DZR Brass |
| 21 | O-Ring (Delta) | EPDM 70 PEROX |
| 22 | O-Ring | EPDM 70 PEROX |
| 23 | Binder Point Blue | |
| 24 | Binder Point Red | |

Technical Data

| | |
|---------------------|-----------------|
| Max Pressure | 25 Bar |
| Working Temperature | -10°C to +120°C |

Dimensions in mm

This data sheet is designed as a guide and should not be regarded as wholly accurate in every detail. We reserve the right to amend the specification of any product without notice.

PN16 Brass Swing Check Valve

Features

- 'M' Press Ends
- Brass Body
- EPDM 'O' Rings
- Pre Press Leak Detection

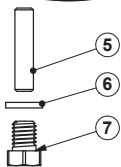
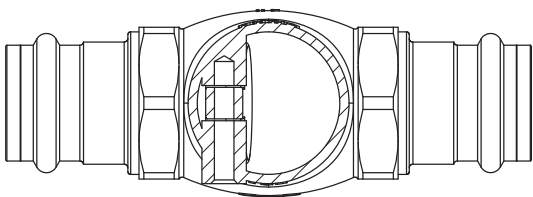
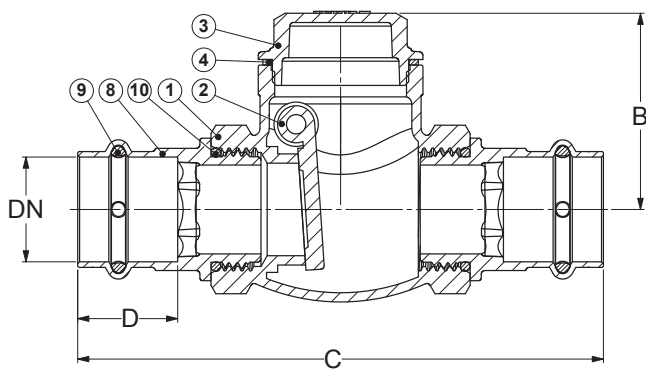

Pressure / Temperature

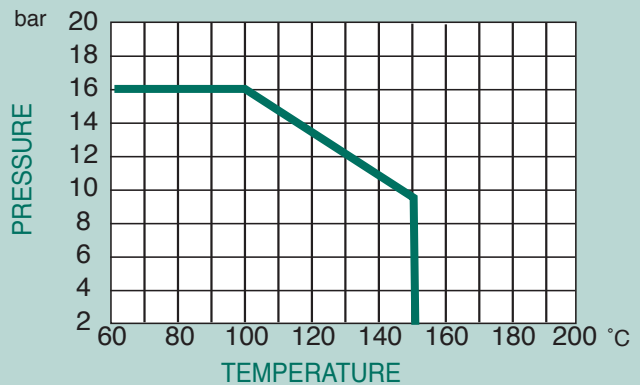

| DN | 15 | 22 | 28 | 35 | 42 | 54 |
|-----|------|------|------|------|------|------|
| B | 42.5 | 46 | 53 | 61 | 62.5 | 70 |
| C | 111 | 130 | 142 | 156 | 172 | 208 |
| D | 22 | 25 | 27 | 27 | 32 | 37 |
| Kgs | 0.32 | 0.48 | 0.74 | 1.04 | 1.25 | 2.07 |

Technical Data

| | |
|---------------------|-----------------|
| Max Pressure | 16 Bar |
| Working Temperature | -10°C to +150°C |

| N. | Part Name | Materials |
|----|----------------|---------------|
| 1 | Body | Brass |
| 2 | Swing Disc | Brass |
| 3 | Plug | Brass |
| 4 | Gasket | NA1100 Black |
| 5 | Pin | Brass |
| 6 | Gasket | Vulkan |
| 7 | Screw | Brass |
| 8 | Adaptor | DZR Brass |
| 9 | O-Ring (Delta) | EPDM 70 PEROX |
| 10 | O-Ring | EPDM 70 PEROX |

Dimensions in mm

This data sheet is designed as a guide and should not be regarded as wholly accurate in every detail. We reserve the right to amend the specification of any product without notice.

PN20 Brass 'Y' Type Strainer

Features

- 'M' Press Ends
- Brass Body
- EPDM 'O' Rings
- Stainless Steel Strainer
- Pre Press Leak Detection

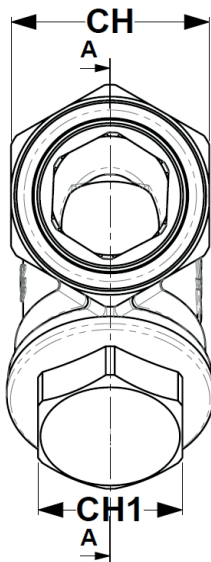
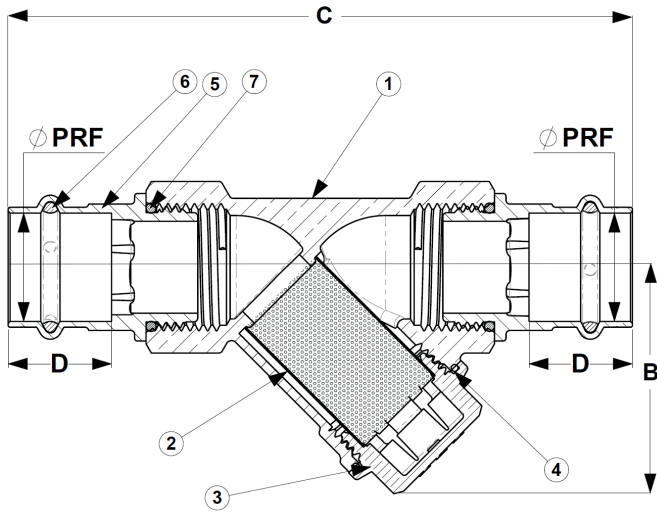
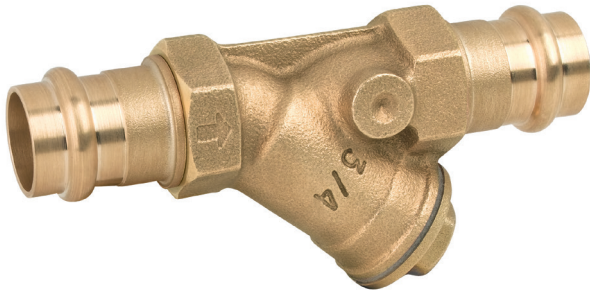

Pressure / Temperature

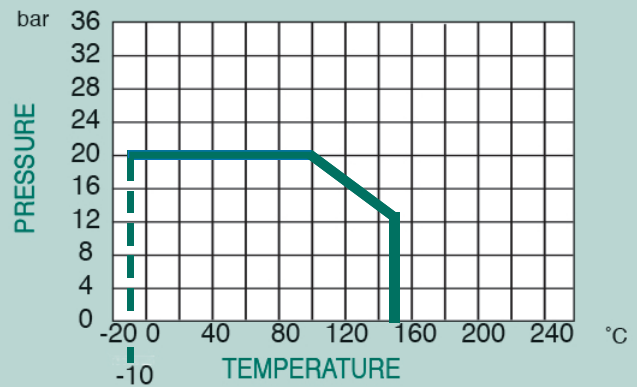

| ØPRF | 15x15 | 22x22 | 28x28 | 35x35 | 42x42 | 54x54 |
|------|-------|-------|-------|-------|-------|-------|
| B | 39.4 | 49 | 59 | 72 | 81 | 98 |
| C | 127 | 145 | 163 | 180 | 201 | 237 |
| D | 22 | 25 | 27 | 27 | 32 | 33 |
| CH | 28 | 33 | 40 | 51 | 56 | 71 |
| CH1 | 18 | 22 | 29 | 34 | 39 | 55 |
| Kgs | 0.3 | 0.5 | 0.7 | 1.2 | 1.4 | 2.5 |

Technical Data

| | |
|---------------------|-----------------|
| Max Pressure | 20 Bar |
| Working Temperature | -10°C to +150°C |

| N. | Part Name | Materials |
|----|----------------|---------------------|
| 1 | Body | Brass |
| 2 | Strainer | Stainless Steel 304 |
| 3 | Bonnet | DZR Brass |
| 4 | O-Ring | FKM70 Red |
| 5 | Joint | DZR Brass |
| 6 | O-Ring (Delta) | EPDM 70 PEROX |
| 7 | O-Ring | EPDM 70 PEROX |

Dimensions in mm

This data sheet is designed as a guide and should not be regarded as wholly accurate in every detail. We reserve the right to amend the specification of any product without notice.

1. SERVICE RECOMMENDATIONS

Art. 55PRS ball valves are designed for direct connection to carbon steel and copper pipe work using standard cold pressure press tools. Art. 55PRS is suitable for sanitary and heating applications and for drinking water and compressed air networks.

2. FEATURES

- Quick & easy installation using standard press tools;
- Installation without the use of solder or soldering torch;
- Patented o-ring design assuring every connection to be pressed & sealed, avoiding installation errors;
- Integrated, compact design eliminating potential leak points;
- Cost effective and installation time reduction compared to threaded valves;
- Suitable for plumbing and heating applications: pressure class PN16 and temperature rating of 120°C;
- Made of DZR brass "CR" which guarantees added protection against corrosion;
- Available in the range DN15 to DN54.

3. CONNECTION TECHNIQUE

The press connection is made by inserting the pipe into the press fitting as far as the marked insertion depth. The connection is created by pressing, using an approved pressing tool.

During the pressing process a deformation takes place on two sections. The first section creates a permanent connection and provides mechanical pipe locking through the mechanical deformation of the press fitting and the pipe. On the second section the seal ring is deformed in its cross section and through its elastic properties creates the permanently tight joint.

4. SEALING RING PROFILE

Traditional press fitting systems use round sealing rings, which can easily be damaged by

careless pipe insertion. Art. 55PRS uses a patented sealing ring with a lenticular profile which fits the press crimp groove.

This provides the following advantages:

- 20% enlargement of the sealing surface area;
- Reduction of the risk of the sealing ring being pressed out or damaged.

The black EPDM Perox sealing ring in the range 15 to 54 mm is supplied with an additional safety feature that during pressure tests will report a leakage in case of accidentally un-pressed connections.

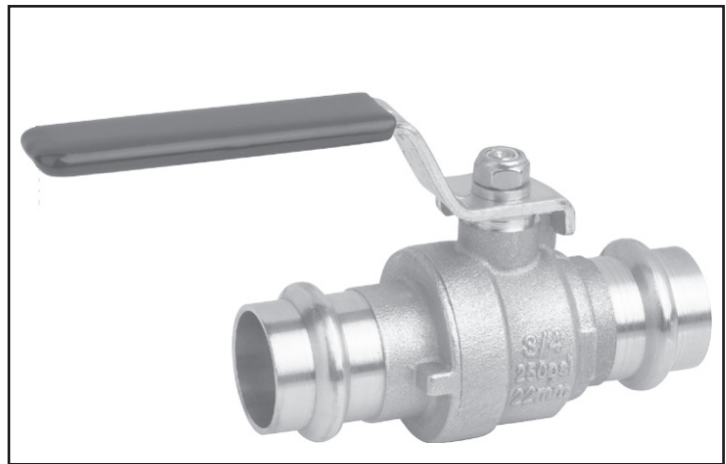

5. PRESSING TOOLS

Basically, pressing tools consist of pressing machine and pressing jaws or collars/chains. Many of the pressing jaws/collars can generally be used with the pressing machines from one manufacturer. Additionally, many manufacturers of pressing tools have standard jaw connections that pressing jaws from other manufacturers can also be used. All metallic press fitting systems have a pressing profile on the press fittings which matches the one of the pressing jaws/collars. For this reason it is necessary to have the information of the jaws to be used by the manufacturer of the press fittings.

For Art. 55PRS pressing, only jaws with "M" profile shall be used.

Note: in addition, it is important to follow exactly the maintenance and servicing instructions issued by the

pressing tool manufacturer.

6. PIPES - CUTTING TO LENGTH AND DEBURRING

Pipes should be cut to length using professional pipe cutters suitable for the material in use.

Alternatively, fine-tooth hacksaws or suitable electric saws may be used. Avoid the use of:

- Tools which may cause tarnishing during the cutting operation;
- Oil-cooled saws;
- Flame cutting or angle grinders.

After cutting, carefully deburr the pipe, both inside and outside to avoid any damage to sealing ring when inserting the pipe into the press fitting.

Deburring can be carried out using manual deburring tools which are suitable for the material in use, whilst for larger dimensions suitable electrical pipe deburring tools can be used.

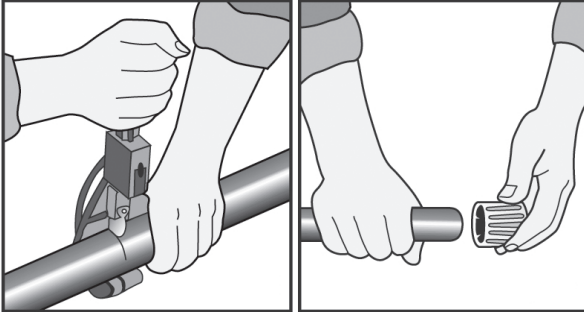

7. MARKING THE INSERTION DEPTH/ STRIPPING

Check that the seal rings in the valve are clean, undamaged and placed correctly. Do not oil or grease the seal rings. Insert pre-prepared pipe end into the valve and push it until the pipes stop, marking the depth of the engagement. Ensure that the insertion depth mark on the pipe corresponds with the press fitting end, otherwise the mechanical stability of the connection cannot be guaranteed. Ensure to have free area around the pipe to operate with the press jaws.

8. PRESSING

Insert the pipe by pushing firmly with a twisting action until it fits tight against the base of the valve end. If the tolerances are so narrow that additional force is required to insert the pipe into the press fitting, then water or soapy water may be used as a lubricant. Oil and grease are not permitted for use as lubricants. Pressing is carried out using suitable pressing tools and dimension-matching pressing jaws or collars/chains.

For Art. 55PRS pressing, only jaws with “M” profile shall be used.

The matching pressing jaw is mounted in the pressing machine, or the appropriate collar/chain mounted on the fitting, depending on the dimensions of the press fitting. The slot of the pressing jaw/collar must be positioned exactly over the press fitting formed end. After pressing, the complete connection should then be checked to ensure that the work has been carried out properly and that the insertion depth is correct. The installer should also ensure that all connections have actually been pressed. The pressing points shall not be subjected to further mechanical loading. The positioning and straightening of the pipes and the sealing of threaded connections must therefore take place before the pressing is carried out.

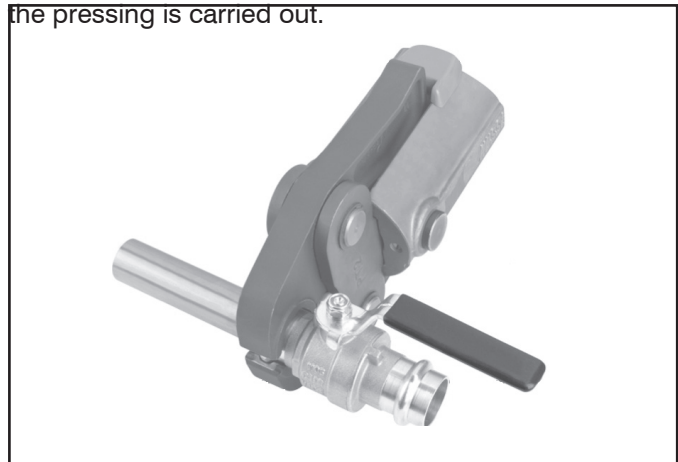



Certificate No. 1437B



Certificate No. 1437A

Distributor