



## Ductile Iron Ball Valve Flanged Ends

### Features

- Flange Mounting PN16 only
- ISO 5211 Direct Mount
- Inside and outside epoxy coating
- Optional lockable Lever
- Blow Out Proof Stem
- DVGW Gas Approved

### Pressure / Temperature

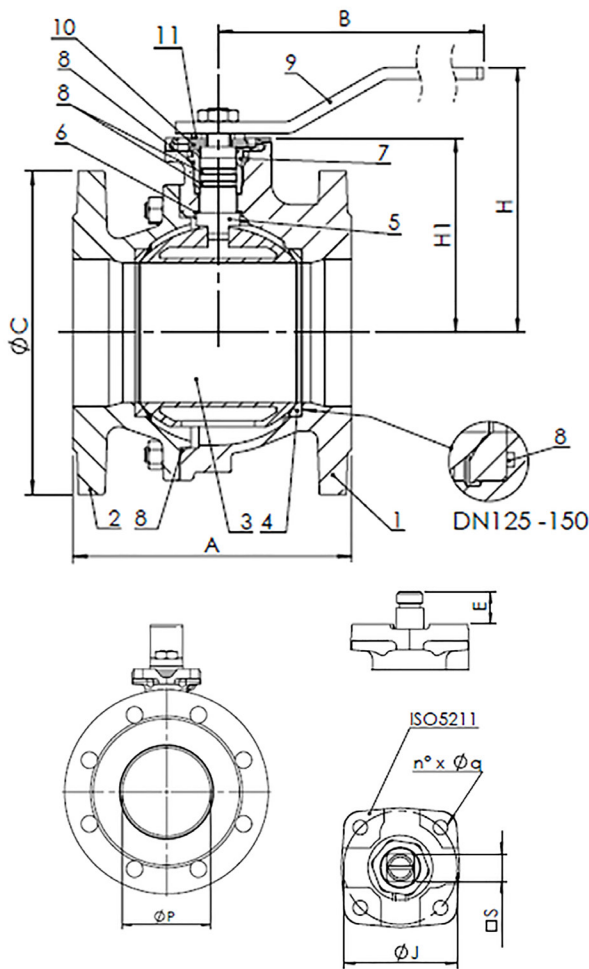
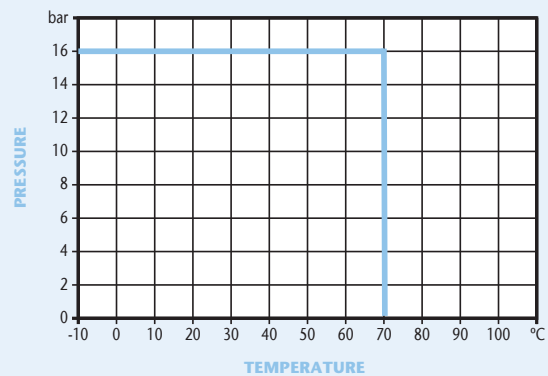

DN	15	20	25	32	40	50	65	80	100	125	150	200
P	15	20	25	32	40	50	63	76	95	120	145	190
A	115	120	125	130	140	150	170	180	190	200	210	400
H	84	84	96	101	125	135	143	165	180	225	243	320
H1	50.5	52	59	64	78.5	87	95	118	132.5	165	182.5	230
B	160	160	170	170	230	230	280	280	360	450	560	1000
C	95	105	115	140	150	165	185	200	220	250	285	340
ISO 5211	F04	F04	F04	F04	F05	F05	F05	F07	F07	F10	F10	F12
J	42	42	42	42	50	50	50	70	70	102	102	125
N° x Øq	4 x 6	4 x 6	4 x 6	4 x 6	4 x 7	4 x 7	4 x 7	4 x 9	4 x 9	4 x 11	4 x 11	4 x 13
E	11.5	11.5	14.5	14.5	17.5	17.5	17.5	20	20	24.5	24.5	27
S	□9	□9	□11	□11	□14	□14	□14	□17	□17	□22	□22	□27
Torque	15	15	18	18	18	20	40	70	100	180	250	600
Kgs	2.6	3.3	4.2	5.8	7.5	9	10.5	15.5	18.5	28	38.5	93

\*Torque - Raw torque with no safety added

N.	Part Name	Material
1	Body	Ductile Iron
2	Flange	Ductile Iron
3	Ball	Brass Chrome Plated
4	Ball seat	PTFE
5	Stem	Brass
6	Sliding washer	PTFE
7	Ring	Brass
8	O-Ring	NBR
9	Lever	Carbon Steel
10	Stop plate	Carbon Steel Galvanised
11	Spring washer	Carbon Steel Galvanised

Drawing represents 15-150mm. For 200mm drawing contact the sales office.

### Technical Data

Maximum Pressure	16 Bar
Working Temperature	-10°C to +70°C

Dimensions in mm

This data sheet is designed as a guide and should not be regarded as wholly accurate in every detail. We reserve the right to amend the specification of any product without notice.