

Gunmetal Safety Valve

Features

- Screwed BSP Parallel (ISO 228) or flange connection
- Body Gunmetal
- Suitable for Gases and Liquids
- Fitted with Diaphragm to Protect Spring Housing
- Set Range 0.5 to 16 Bar
- WRAS Approved
- ISO 4126-1, PED 2014/68/EU
- Marine Approvals - GL, DNV
- ATEX Approval Available at Extra Cost
- 5 Year Warranty
- Test Certificate to EN10204-3.1 Available on Request

Typical Applications

- Pressure Vessels
- Mechanical engineering
- Pump protection
- Pressure booster systems water/air-side
- Cooling/Chilling Systems
- Steam and industrial boiler systems

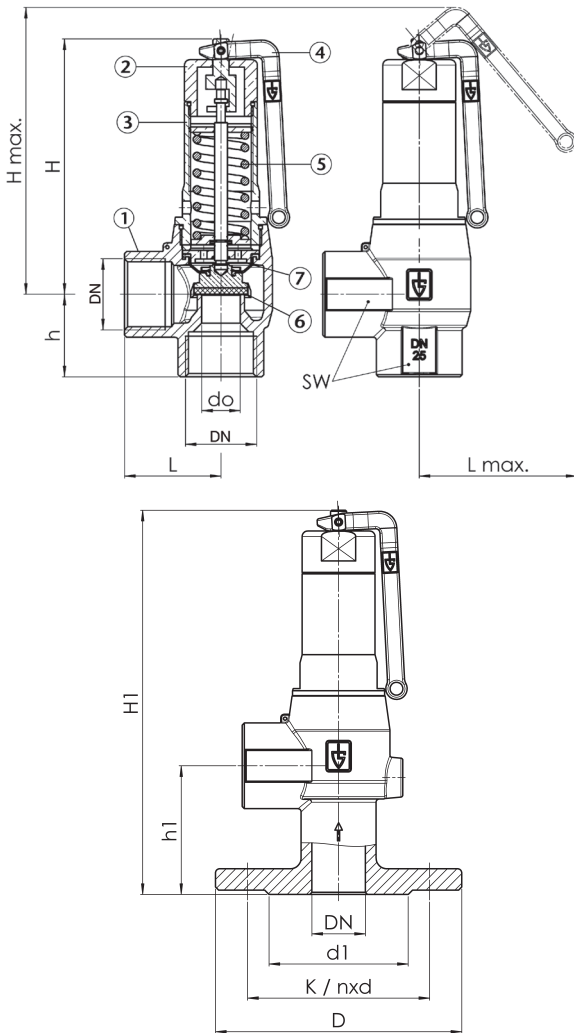

DN	1/2"	3/4"	1"	1 1/4"	1 1/2"	2"	2 1/2"
L	35	42	45	47	58	68	80
Lmax	63	75	78	100	140	150	155
H	90	106	120	150	192	229	275
H1 DIN / ANSI			180 / 180	216 / 216	265 / 265	312 / 312	371 / 371
Hmax	102	120	133	153	210	252	298
h	28	36	38	37	45	55	65
h1 DIN / ANSI			60 / 60	66 / 66	73 / 73	83 / 83	96 / 96
D DIN / ANSI			115 / 110	140 / 115	150 / 125	165 / 150	185 / 180
d1 DIN / ANSI			65 / 50.8	76 / 63.5	84 / 73	99 / 92.1	118 / 104.8
SW	27	34	41	50	60	70	90
do	13	15	18	23	30	39	48
K / nxd (DIN)			85 / 4x14	100 / 4x18	110 / 4x18	125 / 4x18	145 / 4x18
K / nxd (ANSI)			79.4 / 4x15.9	88.9 / 4x15.9	98.4 / 4x15.9	120.7 / 4x19.1	139.7 / 4x19.1
kg	0.5	0.8	1.1	1.7	3.3	5.8	8.9
kg FLDIN / FLANSI			2.0 / 1.9	3.4 / 2.9	4.1 / 3.5	8.4 / 7.9	12.0 / 11.8

N.	Part Name	Materials
1	Body	Gunmetal
2	Housing Cap	Brass / Gunmetal
3	Spring Housing	Brass / Gunmetal
4	Lifting Lever	Stainless Steel CF8M
5	Spring	Stainless Steel 302
6	Seat-Seal	PTFE
7	Diaphragm	EPDM

Technical Data

Max Pressure	16 Bar
Working Temperature	EPDM Diaphragm -50°C to +195°C

Dimensions in mm

This data sheet is designed as a guide and should not be regarded as wholly accurate in every detail. We reserve the right to amend the specification of any product without notice.

Discharge Capacities

DN Bar	1/2"				3/4"				1"				1 1/4"			
	Nm ³ /h	kg/h	m ³ /h	kW	Nm ³ /h	kg/h	m ³ /h	kW	Nm ³ /h	kg/h	m ³ /h	kW	Nm ³ /h	kg/h	m ³ /h	kW
0.5	74	56	2.1	36	85	64	2.7	41	105	79	3.4	51	208	157	6.6	101
1	106	84	2.9	53	124	97	3.7	62	156	123	4.6	78	315	251	8.9	158
2	173	136	4.1	84	204	159	5.2	98	266	208	6.5	128	525	413	12.6	254
3	233	181	5.0	110	279	217	6.4	131	372	289	8.0	175	729	570	15.4	344
4	293	226	5.8	135	357	276	7.4	164	477	368	9.2	219	916	710	17.7	423
5	352	272	6.5	159	438	338	8.2	198	574	443	10.3	260	1103	851	19.8	500
6	412	318	7.1	184	512	395	9.0	228	671	518	11.3	299	1289	992	21.7	576
7	471	364	7.7	207	586	452	9.7	258	768	593	12.2	338	1476	1130	23.5	650
8	531	410	8.2	231	660	509	10.4	287	865	668	13.1	376	1662	1269	25.1	724
9	591	456	8.7	254	734	566	11.0	315	963	743	13.9	414	1849	1408	26.6	795
10	650	502	9.2	276	808	623	11.6	344	1060	818	14.6	451	2036	1546	28.1	865
11	710	548	9.6	299	882	680	12.2	372	1157	892	15.3	487	2222	1683	29.4	938
12	770	594	10.1	321	956	738	12.7	399	1254	967	16.0	523	2409	1820	30.7	1008
13	829	640	10.5	343	1030	795	13.3	426	1351	1042	16.7	559	2595	1958	32.0	1078
14	889	686	10.9	365	1104	852	13.8	453	1448	1117	17.3	594	2782	2097	33.2	1145
15	948	732	11.3	386	1178	909	14.3	480	1545	1192	17.9	629	2969	2234	34.4	1213
16	1008	778	11.6	407	1252	966	14.7	506	1643	1267	18.5	664	3155	2372	35.5	1282

DN Bar	1 1/2"				2"				2 1/2"			
	Nm ³ /h	kg/h	m ³ /h	kW	Nm ³ /h	kg/h	m ³ /h	kW	Nm ³ /h	kg/h	m ³ /h	kW
0.5	285	215	9.2	138	494	372	15.5	239	729	549	23.6	352
1	414	331	12.5	208	700	559	21.1	352	1034	826	31.9	520
2	677	534	17.6	327	1145	902	29.8	553	1734	1366	45.1	838
3	931	728	21.6	439	1573	1230	36.5	741	2383	1862	55.2	1123
4	1169	906	24.9	540	1975	1532	42.1	913	2992	2320	63.8	1383
5	1407	1085	27.9	638	2378	1834	47.1	1078	3602	2778	71.3	1633
6	1645	1266	30.5	736	2780	2139	51.6	1243	4211	3240	78.1	1883
7	1883	1441	33.0	830	3182	2436	55.7	1403	4821	3690	84.4	2125
8	2121	1619	35.2	924	3585	2737	59.5	1561	5430	4146	90.2	2365
9	2359	1796	37.4	1014	3987	3036	63.2	1713	6040	4599	95.7	2595
10	2597	1973	39.4	1104	4389	3334	66.6	1866	6649	5050	100.8	2827
11	2835	2148	41.3	1197	4792	3630	69.8	2023	7259	5499	105.8	3065
12	3074	2322	43.1	1286	5194	3925	72.9	2173	7868	5945	110.5	3291
13	3312	2498	44.9	1376	5597	4222	75.9	2325	8478	6396	115.0	3522
14	3550	2675	46.6	1461	5999	4521	78.8	2468	9087	6848	119.3	3739
15	3788	2850	48.2	1548	6401	4817	81.5	2616	9697	7297	123.5	3962
16	4026	3026	49.8	1635	6804	5114	84.2	2764	10306	7747	127.6	4187

Seat-Seal/Diaphragm Options

Option	Materials	Type	Working Temp.
PTFE/EPDM	Polytetrafluorethylen/Ethylen-Propylene-Diene (Standard)	Flat seal and moulded diaphragm	-50°C to +195°C
EPDM/EPDM	Ethylen-Propylene-Diene/Ethylen-Propylene-Diene	Flat seal and moulded diaphragm	-50°C to +150°C
PTFE/FKM	Polytetrafluorethylen/Fluorcarbon	Flat seal and moulded diaphragm	-30°C to +200°C
FKM/FKM	Fluorcarbon/Fluorcarbon	Elastomere seals and moulded diaphragm	-20°C to +200°C

Dimensions in mm

This data sheet is designed as a guide and should not be regarded as wholly accurate in every detail. We reserve the right to amend the specification of any product without notice.