

3 Port Flanged Rotary Mixing Valve

Features

- Cast Iron body and plug (EN-GJL-250)
- Hydraulic tightness: EPDM
- Handle: ABS
- Manual or Actuated
- Suitable fluids: Water, glycoled water (max 30%)
- Connections: Flanged connections ISO 7005

DN	65	80	100	125	150
Kv	100	185	310	510	820
A	200	234	260	296	240
B	160	190	210	240	265
C	190	210	240	270	300
H	14	18	18	18	18
I	130	150	170	200	225
Hole N°	4	4	4	8	8
Kgs	11	15	22	34	50

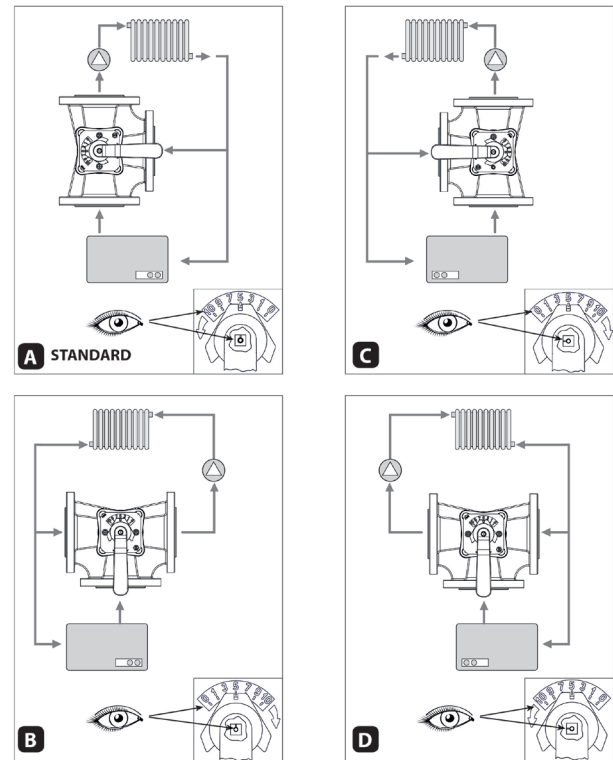
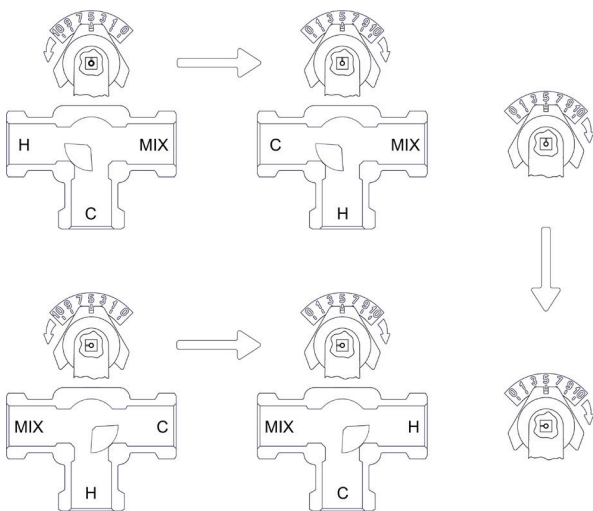

Technical Data

Max Pressure	6 Bar (PN6)
Working Temperature	-10°C to +110°C
Rotor's rotation angle:	90°
Leakage:	DN50 - DN100 0.1% del Kvs DN125 - DN150 0.5% del Kvs

Dimensions in mm

This data sheet is designed as a guide and should not be regarded as wholly accurate in every detail. We reserve the right to amend the specification of any product without notice.