

PN25 Cast Iron Swing Check Valve

Features

- Flange Mounting PN25 Only
- Flange conforms to BS EN1092 PN25
- BS5153 (BS EN 558-1 Series 21)



Pressure/Temperature

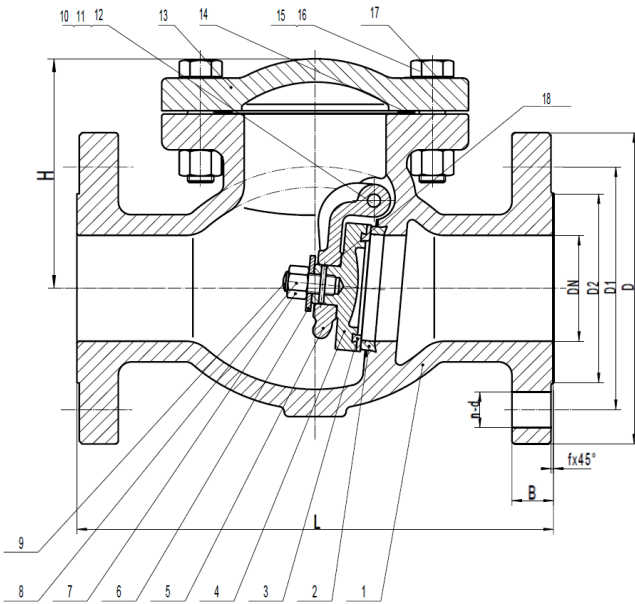
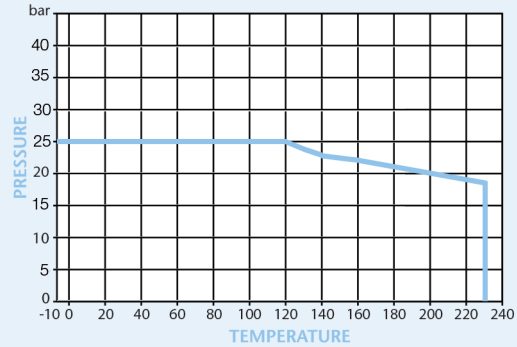

	2"	2½"	3"	4"	5"	6"	8"	10"	12"
L	267	292	318	356	400	444	533	622	711
D	165	191	210	254	279	318	381	445	521
D1	125	145	160	190	220	250	310	370	430
D2	99	118	132	156	184	211	274	330	389
B	22.2	25.4	28.6	31.8	34.9	36.5	41.3	47.6	50.8
n-d	4-19	8-19	8-19	8-23	8-28	8-28	12-28	12-31	16-31
f	3	3	3	3	3	3	3	3	4
H	135	150	166	190	206	244	291	337	383
Kgs	17.6	31	35.8	55.7	80.4	110.9	180	277	408.5

N.	Part Name	Materials
1	Body	Cast Iron - BS EN1561 EN-GJL-250
2	Seat Ring	Cast Bronze - BS1400 LG2
3	Disc Ring	Cast Bronze - BS1400 LG2
4	Disc	Cast Iron - BS EN1561 EN-GJL-250
5	Hanger	Ductile Iron - BS EN1563 EN-GJS-450-10
6	Washer	Stainless Steel - BS970 304S15
7	Nut	Stainless Steel - BS970 304S15
8	Split Pin	Stainless Steel - BS970 304S15
9	Disc Screw	Stainless Steel - BS970 304S15
10	Side Pin	Brass - BS2874 CZ122
11	Gasket	Teflon
12	Hanger Pin	Stainless Steel - BS970 304S15
13	Bonnet	Cast Iron - BS EN1561 EN-GJL-250
14	Gasket	EPDM - BS EN681-1 IRHD66-75
15	Bolt	Stainless Steel - BS970 304S15
16	Nut	Stainless Steel - BS970 304S15
17	Identification Plate	Aluminium
18	Pin	Stainless Steel - BS970 304S15

Technical Data

Maximum Pressure	25 Bar
Working Temperature	-10°C to +230°C

Dimensions in mm

This data sheet is designed as a guide and should not be regarded as wholly accurate in every detail. We reserve the right to amend the specification of any product without notice.