



ANSI 125 Ductile Iron Resilient Seat Gate Valve

Features

- BS5163, Type B cover and stem
- Non rising stem, clockwise closing
- Flange mounting to ANSI 125 (B16.1)
- Face to face length to EN558-1 Series 3
- WRAS Approved EPDM
- Internally and externally fusion bonded epoxy coated WRAS approved

Pressure/Temperature

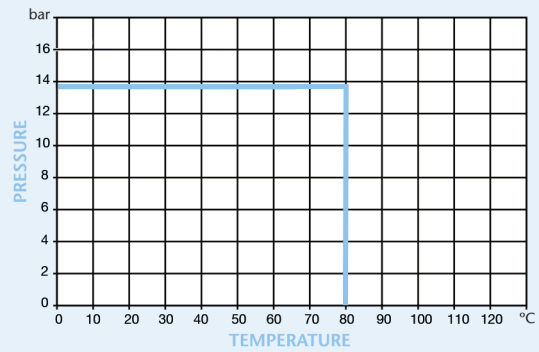

Handwheel, gearbox or cap top operation

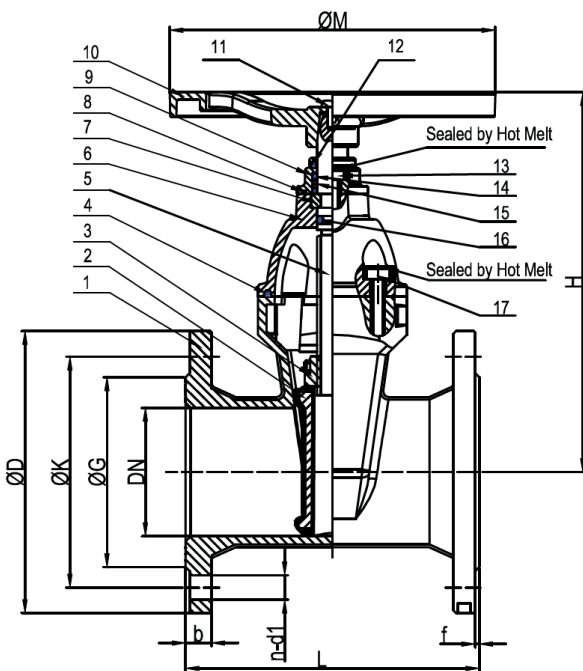
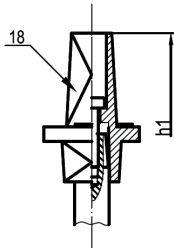

Technical Data

Maximum Pressure	13.8 Bar
Working Temperature	0°C to +80°C

	2"	2½"	3"	4"	5"	6"	8"	10"	12"	14"	16"	18"	20"	24"
L	178	190	203	229	254	267	292	330	356	381	406	432	457	508
H	215	235	265	315	350	385	485	600	680	810	890	1050	1230	1260
M	200	200	254	254	315	315	315	406	406	500	500	500	650	650
h1	285	300	320	390	430	470	560	680	770	900	1000	1150	1330	1510
D	165	185	200	220	250	285	340	405	483	520	580	640	715	840
K	121	140	152	191	216	241	298	362	432	476	540	578	635	749
G	99	118	132	156	184	211	266	319	370	429	480	548	609	720
n-d1	4- Ø19	4- Ø19	4- Ø19	8- Ø19	8- Ø19	8- Ø22	8- Ø22	12- Ø25	12- Ø25	12- Ø28	16- Ø28	16- Ø32	20- Ø32	20- Ø35
b	19	19	19	19	19	19	20	22	24.5	26.5	28	30	31.5	36
f	3	3	3	3	3	3	3	3	4	4	4	4	4	5
Kgs	9	12	14	19	24	31	52	87	116	185	225	360	450	690

N.	Part Name	Materials
1	Body	Ductile Iron GGG50 - BS2789
2	Disc	Ductile Iron GGG50 + EPDM (WRAS)-BS2789
3	Stem Nut	Brass HPb59-1 - BS2872-2874
4	Bonnet Gasket	EPDM (WRAS) - ISO4633
5	Stem	Stainless Steel 316 - BS970
6	Bonnet	Ductile Iron GGG50 - BS2789
7	Holding Ring	Brass HPb59-1 - BS2872-2874
8	O-Ring	EPDM (WRAS) - ISO4633
9	Gland	Ductile Iron GGG50 - BS2789
10	Hand Wheel	Ductile Iron GGG50 - BS2789
11	Screw	Stainless Steel 316 - BS970
12	Dust Ring	EPDM (WRAS) - ISO4633
13	Gland Bolts	Stainless Steel 316 - BS970
14	O-Ring	EPDM (WRAS) - ISO4633
15	Washers	Nylon 66
16	O-Ring	EPDM (WRAS) - ISO4633
17	Bonnet Bolts	Stainless Steel 316 - BS970
18	Cap Top	Ductile Iron GGG50 - BS2789

Dimensions in mm

This data sheet is designed as a guide and should not be regarded as wholly accurate in every detail. We reserve the right to amend the specification of any product without notice.