



## PN25 Ductile Iron Resilient Seat Gate Valve

### Features

- BS5163, Type B cover and stem
- Non rising stem, clockwise closing
- Flange mounting to EN1092-2 PN25
- Face to face length to EN558-1 Series 3
- WRAS Approved EPDM
- Internally and externally fusion bonded epoxy coated WRAS approved

### Pressure/Temperature

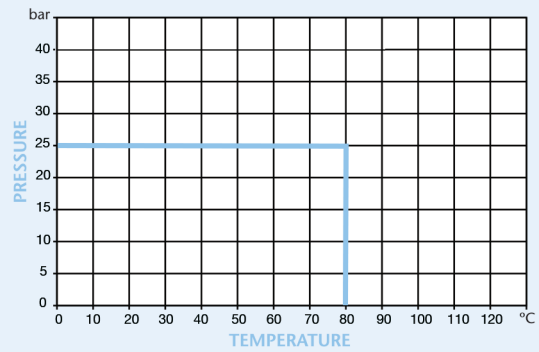

Handwheel, gearbox or cap top operation

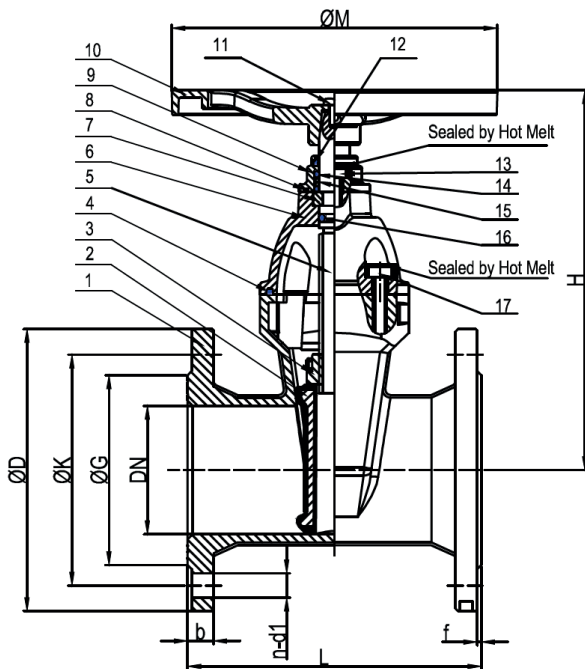
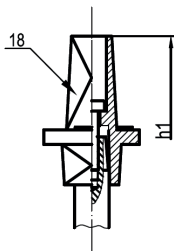

	2"	2½"	3"	4"	5"	6"	8"	10"	12"
L	178	190	203	229	254	267	292	330	356
H	215	235	265	315	350	385	485	600	680
M	200	200	254	254	315	315	315	406	406
h1	285	300	320	390	430	470	560	680	770
D	165	185	200	235	270	300	360	425	485
K	125	145	160	190	220	250	310	370	430
G	99	118	132	156	184	211	274	330	389
n-d1	4-Ø19	8-Ø19	8-Ø19	8-Ø23	8-Ø28	8-Ø28	12-Ø28	12-Ø31	16-Ø31
b	19	19	19	19	19	20	22	25	28
f	3	3	3	3	3	3	3	3	4
Kgs	9	12	14	19	24	31	52	87	116

### Technical Data

Maximum Pressure	25 Bar
Working Temperature	0°C to +80°C

N.	Part Name	Materials
1	Body	Ductile Iron GGG50 - BS2789
2	Disc	Ductile Iron GGG50 + EPDM (WRAS)-BS2789
3	Stem Nut	Brass HPb59-1 - BS2872-2874
4	Bonnet Gasket	EPDM (WRAS) - ISO4633
5	Stem	Stainless Steel 316 - BS970
6	Bonnet	Ductile Iron GGG50 - BS2789
7	Holding Ring	Brass HPb59-1 - BS2872-2874
8	O-Ring	EPDM (WRAS) - ISO4633
9	Gland	Ductile Iron GGG50 - BS2789
10	Hand Wheel	Ductile Iron GGG50 - BS2789
11	Screw	Stainless Steel 316 - BS970
12	Dust Ring	EPDM (WRAS) - ISO4633
13	Gland Bolts	Stainless Steel 316 - BS970
14	O-Ring	EPDM (WRAS) - ISO4633
15	Washers	Nylon 66
16	O-Ring	EPDM (WRAS) - ISO4633
17	Bonnet Bolts	Stainless Steel 316 - BS970
18	Cap Top	Ductile Iron GGG50 - BS2789

Dimensions in mm

This data sheet is designed as a guide and should not be regarded as wholly accurate in every detail. We reserve the right to amend the specification of any product without notice.