

DEUFF

Features

- Female iron pipe thread to female brass thread
- Available with BSP Parallel threads (ISO 228/1) or NPT threads (ANSI B1.20.1)

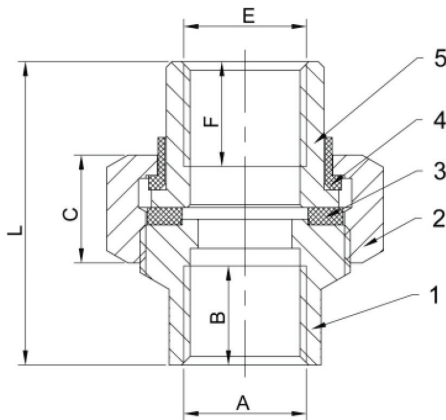

Technical Data

Max Pressure	17.2 Bar (250psi)
Max Temperature	82°C (180°F)

DN	1/2"	3/4"	1"	1 1/4"	1 1/2"	2"
A	G1/2"	G3/4"	G1"	G1 1/4"	G1 1/2"	G2"
B	17	19	20	21	23	25
C	18.5	18.5	22	25.5	27	32
E	G1/2"	G3/4"	G1"	G1 1/4"	G1 1/2"	G2"
F	18	19	23	25	23	28
L	52	56	63	69.5	70	78.5
Kgs	0.21	0.30	0.44	0.64	1.25	2.20

N.	Part Name	Materials
1	Union Adaptor	Steel / Zinc Plated - Q235
2	Union Nut	Steel / Zinc Plated - Q235
3	Gasket	EPDM
4	Insulator	PEHD
5	Union End	DZR Brass - CW602N

DEUMF

Features

- Female iron pipe thread to male brass pipe threaded connections
- Available with BSP Parallel threads (ISO 228/1) or NPT threads (ANSI B1.20.1)

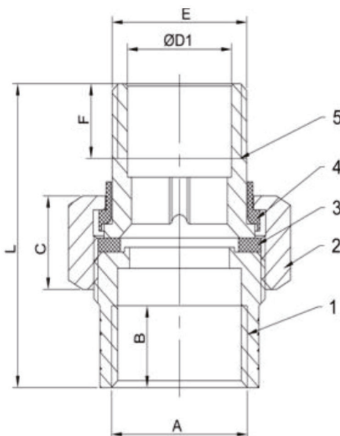

Technical Data

Max Pressure	17.2 Bar (250psi)
Max Temperature	82°C (180°F)

DN	1/2"	3/4"	1"	1 1/4"	1 1/2"	2"
A	G1/2"	G3/4"	G1"	G1 1/4"	G1 1/2"	G2"
B	16.5	17.5	17.5	25	26.5	27
C	18.5	18.5	20	22	24.5	27
ØD1	15.5	20.5	25.5	32.5	38.5	50
E	G1/2"	G3/4"	G1"	G1 1/4"	G1 1/2"	G2"
F	11	13	16	17	20	20.5
L	49.5	53	65	75	75	82.5
Kgs	0.16	0.23	0.31	0.48	0.70	1.24

N.	Part Name	Materials
1	Union Adaptor	Steel / Zinc Plated - Q235
2	Union Nut	Steel / Zinc Plated - Q235
3	Gasket	EPDM
4	Insulator	PEHD
5	Union End	DZR Brass - CW602N

Dimensions in mm

This data sheet is designed as a guide and should not be regarded as wholly accurate in every detail. We reserve the right to amend the specification of any product without notice.