

## PN16 Adjustable Pressure Reducing Valve with Low Flow Bypass

### Features

- Automatic Control Valve
- Suitable for potable water applications
- WRAS approved epoxy coated body
- Pressure adjusted by Integral Pilot Valve
- Conforms to BS EN 558-1 Series 1
- Flange conforms to BS EN 1092 PN16
- Available flanged PN25
- Stainless Steel Pilot Tubing and Valves

### Pressure/Temperature

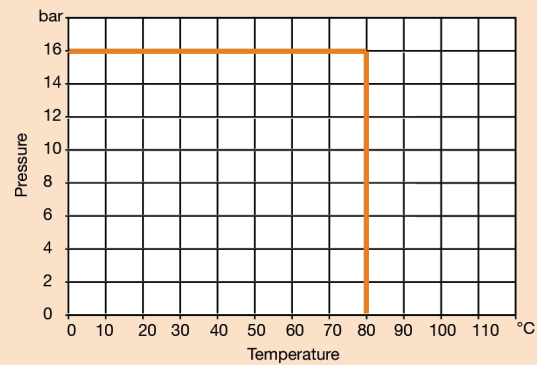

DN	50	65	80	100	125	150	200	250	300
L	230	290	310	350	400	480	600	730	850
E	165	185	200	220	250	285	340	405	460
C	125	145	160	180	210	240	295	355	410
n-d	4-Ø19	4-Ø19	8-Ø19	8-Ø19	8-Ø19	8-Ø23	12-Ø23	12-Ø28	12-Ø28
B	365	375	383	393	405	422	448	478	605
H	482	505	520	540	570	605	660	725	780
H1	350	413	420	430	445	463	490	523	550
Kgs	13	17	23	30	65	69	132	315	420

N.	Part Name	Materials
1	Body	Ductile Iron
2	Stem	Stainless Steel 304
3	Seat	Stainless Steel 304
4	O-Ring	NBR
5	Disc Ring	NBR
6	Disc Retailer	Ductile Iron
7	Disc Guide	Ductile Iron
8	Diaphragm	NBR + Nylon
9	Diaphragm Washer	Ductile Iron
10	Spring	Stainless Steel 304
11	Cover Bearing	Stainless Steel 304
12	Screw	Stainless Steel 304
13	Washer	Stainless Steel 304
14	Cover	Ductile Iron
15	Strainer	Stainless Steel 304
16	Needle Valve	Stainless Steel 304
17	Pilot Valve	Stainless Steel 304
18	Ball Valve	Stainless Steel 304
19	Low Bypass Pilot Valve	Stainless Steel 304

### Technical Data

Max Pressure	16 Bar
Working Temperature	0°C to +80°C

Dimensions in mm

This data sheet is designed as a guide and should not be regarded as wholly accurate in every detail. We reserve the right to amend the specification of any product without notice.

Pilot Valve Detail

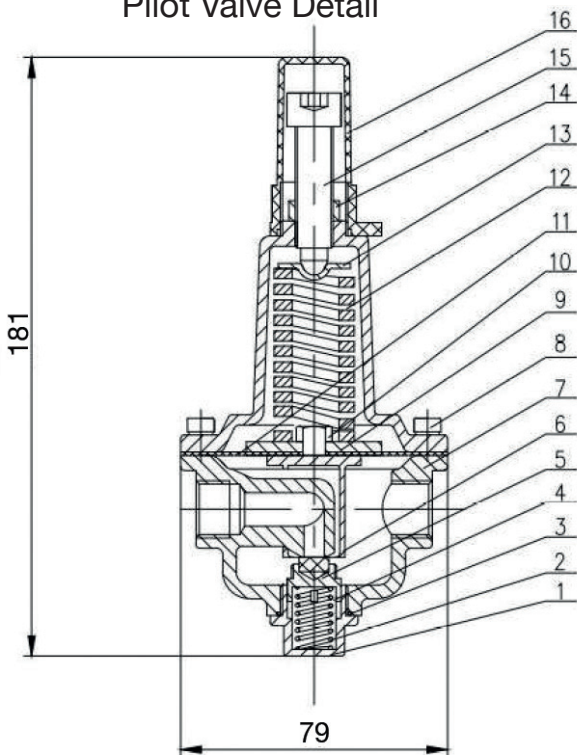

Pilot Valve

N.	Part Name	Materials
1	Plug	Stainless Steel 304
2	Spring	Stainless Steel 304
3	O-Ring	NBR
4	Seat	Stainless Steel 304
5	Disc	NBR
6	Yoke	Stainless Steel 304
7	Body	Stainless Steel 304
8	Screw	Stainless Steel 304
9	Diaphragm Washer	Stainless Steel 304
10	Nut	Stainless Steel 304
11	Diaphragm	NBR + Nylon
12	Spring	Stainless Steel 304
13	Spring Holder	Stainless Steel 304
14	Locking Nut	Stainless Steel 304
15	Adjusting Screw	Stainless Steel 304
16	Cap	ABS

Fitted with Standard Pilot Valve  
2.10 to 20.00 Bar (30 to 300 PSI)  
Factory set to 5.50 Bar (80 PSI)

Low Flow Bypass Range  
1.37 to 12.00 Bar (20 to 175 PSI)

Operation Cavitation Chart

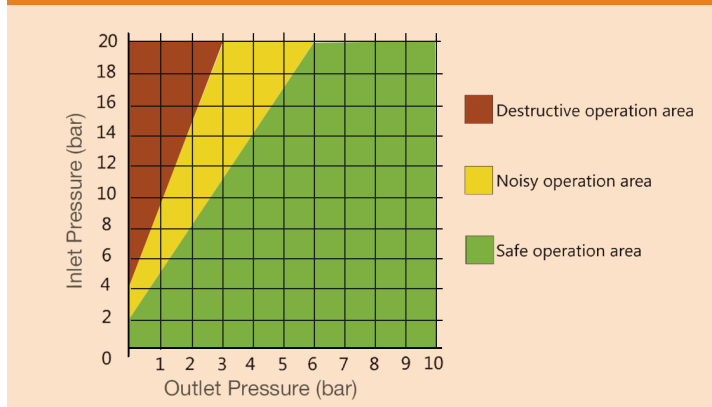

Flow curve of the main valve at fully open status

