

Cast & Ductile Iron Valves

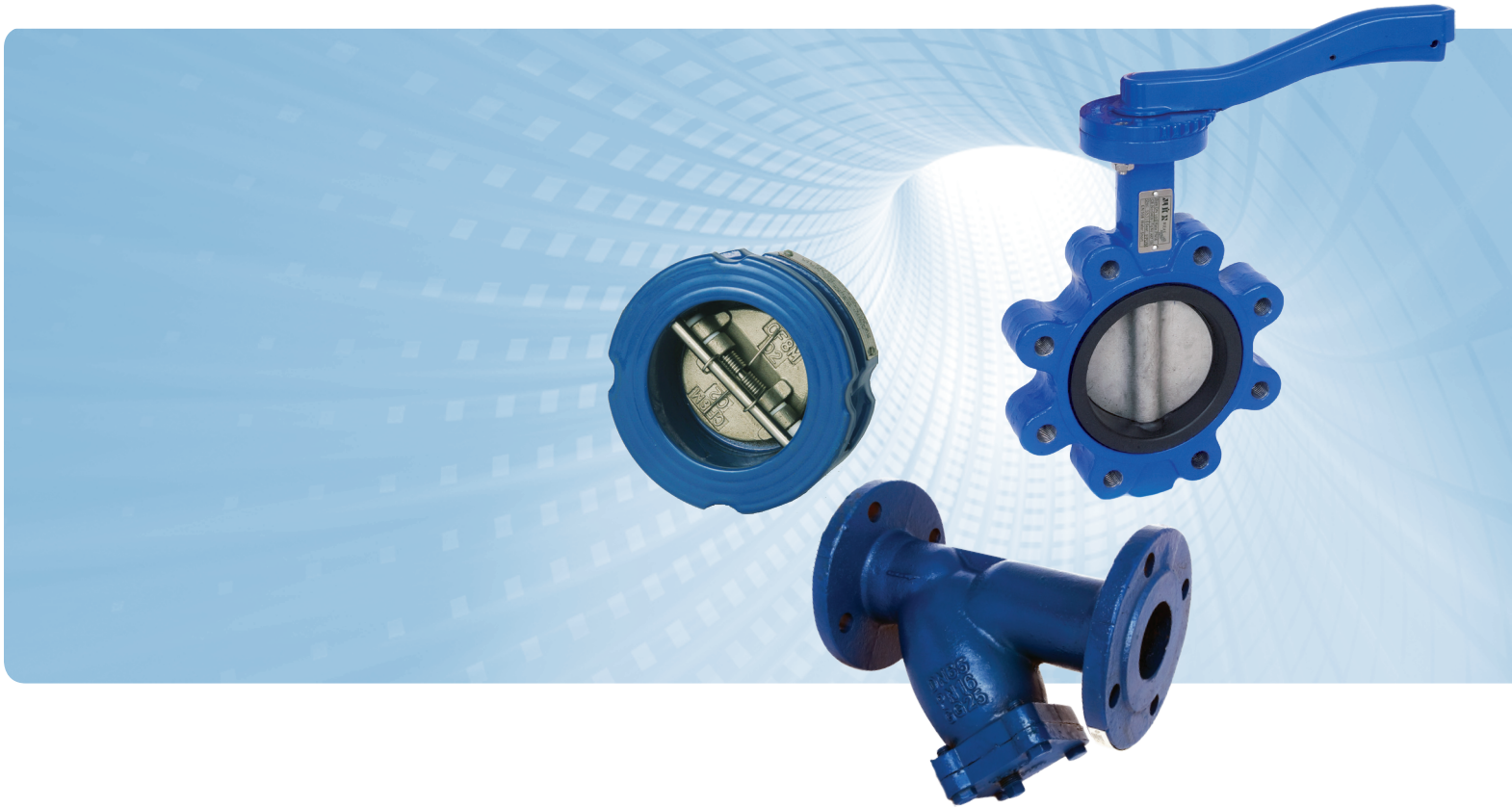

Product Information

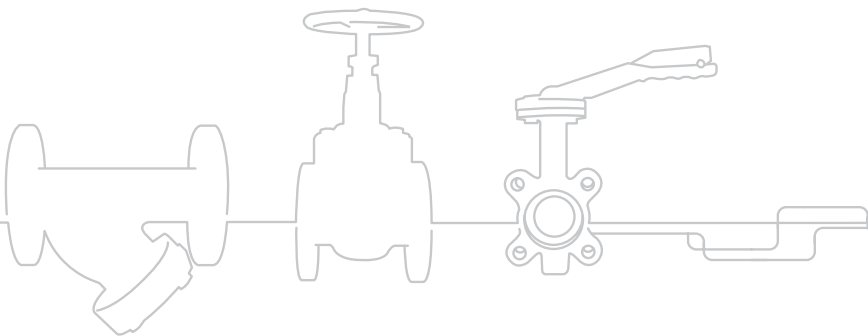

Cast Iron Ball Valve Flanged Ends

Features

- Flange Mounting PN16 Only
- ISO 5211 Direct Mount (Not 200mm)
- Art 77 Plated Brass
- BS EN 558-1 Series 14

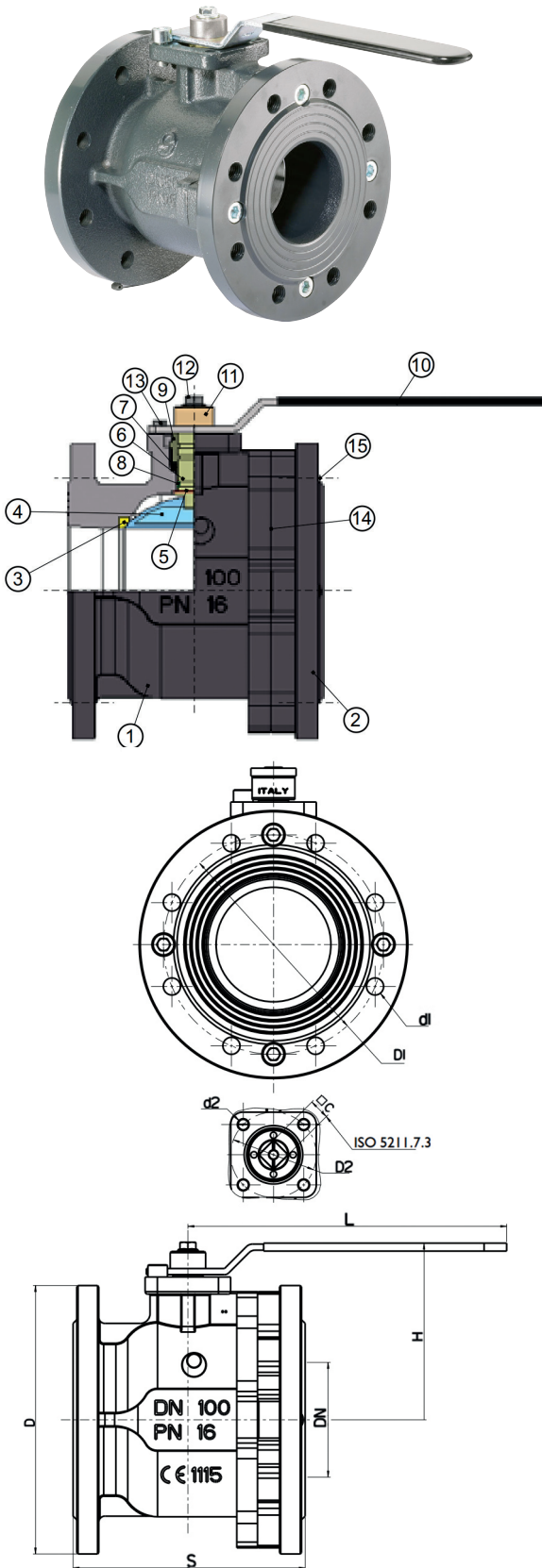

Pressure/Temperature

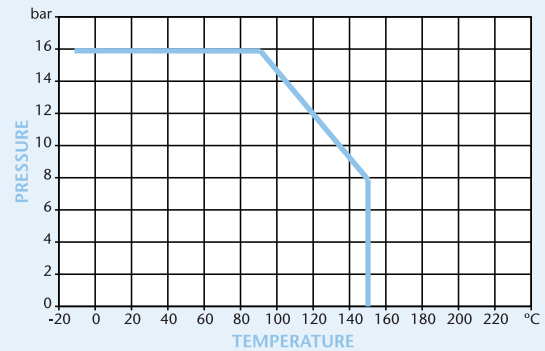

DN	20	25	32	40	50	65	80	100	125	150	200
Ø	20	25	32	40	50	61	74	95	120	145	200
S	120	125	130	140	150	170	180	190	200	210	400
H	73	77	82	92	99	121	130	144	185	204	325
L	200	200	200	240	240	260	260	260	450	450	700
D	105	115	140	150	165	185	200	220	250	285	340
a	75	85	100	110	125	145	160	180	210	240	295
ISO	F04	F04	F04	F05	F05	F07	F07	F07	F10	F10	N/A
ØF	42	42	42	50	50	70	70	70	102	102	N/A
□C	9	9	9	14	14	17	17	17	22	22	N/A
N-Mb	4xM12	4xM12	4xM16	4xM16	4xM16	4xM16	8xM16	8xM16	8xM16	12xM20	12x22
Torque	20	25	31,25	37,5	50	62,5	100	150	175	187,5	N/A
Kgs	3.0	3.8	5.4	6.0	7.5	12.0	14.5	18.2	32.0	39.5	94.0

N.	Part Name	Materials
1	Body	Cast Iron GG25
2	Flange	Cast Iron GG25
3	Seat	PTFE
4	Ball	CP Brass
5	Seal	PTFE
6	Stem	Steel
7	O-Ring	HNBR
8	Stem Seat	PTFE
9	Packing Nut	Brass
10	Handle	Steel PVC Coated
11	Cap	Brass
12	Screw	Steel Zinc Plated
13	Screw	Steel Zinc Plated
14	O-Ring	HNBR
15	Screw	Steel Zinc Plated

Technical Data

Pressure 16 Bar

Working Temperature -10°C to +150°C

Dimensions in mm

This data sheet is designed as a guide and should not be regarded as wholly accurate in every detail. We reserve the right to amend the specification of any product without notice.



Ductile Iron Ball Valve Flanged Ends

Features

- Flange Mounting PN16 only
- ISO 5211 Direct Mount
- Inside and outside epoxy coating
- Optional lockable Lever
- Blow Out Proof Stem
- Chrome Plated Brass Ball

Pressure / Temperature

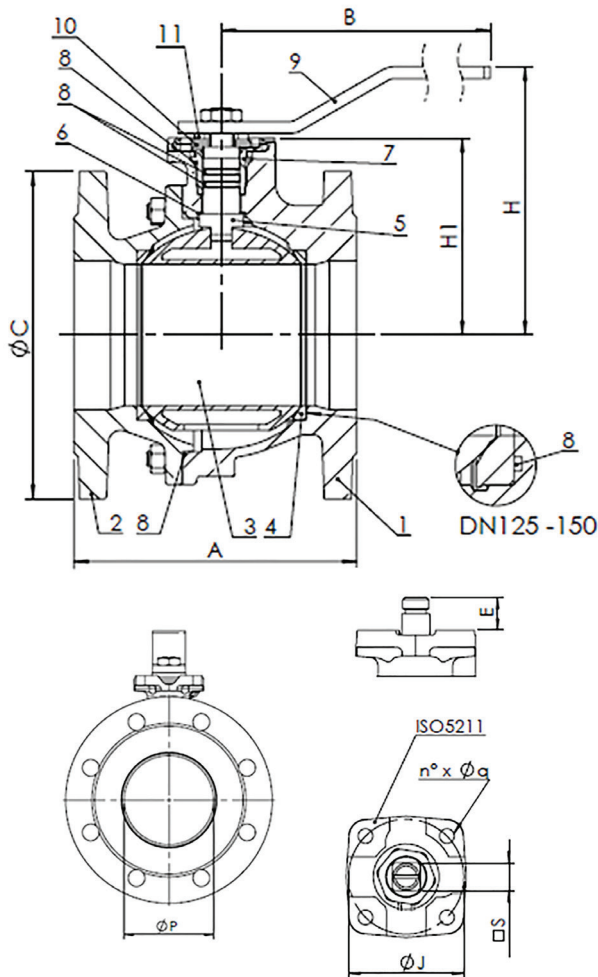
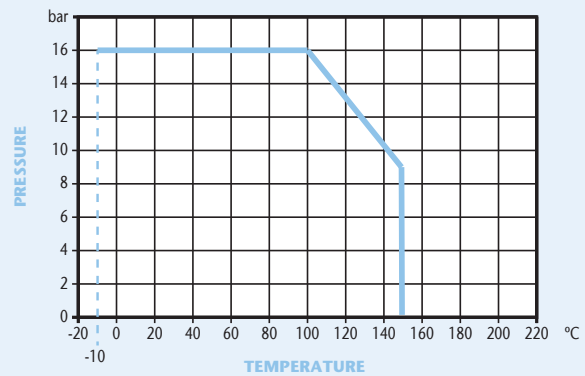

DN	15	20	25	32	40	50	65	80	100	125	150	200
P	15	20	25	32	40	50	63	76	95	120	145	190
A	115	120	125	130	140	150	170	180	190	200	210	400
H	84	84	96	101	125	135	143	165	180	225	243	320
H1	50.5	52	59	64	78.5	87	95	118	132.5	165	182.5	230
B	160	160	170	170	230	230	230	280	360	450	560	1000
C	95	105	115	140	150	165	185	200	220	250	285	340
ISO 5211	F04	F04	F04	F04	F05	F05	F05	F07	F07	F10	F10	F12
J	42	42	42	42	50	50	50	70	70	102	102	125
N° x Øq	4 x 6	4 x 6	4 x 6	4 x 6	4 x 7	4 x 7	4 x 7	4 x 9	4 x 9	4 x 11	4 x 11	4 x 13
E	11.5	11.5	14.5	14.5	17.5	17.5	17.5	20	20	24.5	24.5	27
S	□9	□9	□11	□11	□14	□14	□14	□17	□17	□22	□22	□27
Torque	15	15	18	18	18	20	40	70	100	180	250	600
Kgs	2.6	3.3	4.2	5.8	7.5	9	10.5	15.5	18.5	28	38.5	93

*Torque - Raw torque with no safety added

N.	Part Name	Material
1	Body	Ductile Iron
2	Flange	Ductile Iron
3	Ball	Brass Chrome Plated
4	Ball seat	PTFE
5	Stem	Brass
6	Sliding washer	PTFE
7	Ring	Brass
8	O-Ring	Viton
9	Lever	Carbon Steel
10	Stop plate	Carbon Steel Galvanised
11	Spring washer	Carbon Steel Galvanised

Drawing represents 15-150mm. For 200mm drawing contact the sales office.

Technical Data

Maximum Pressure	16 Bar
Working Temperature	-10°C to +150°C

Dimensions in mm

This data sheet is designed as a guide and should not be regarded as wholly accurate in every detail. We reserve the right to amend the specification of any product without notice.

Ductile Iron Butterfly Valve Wafer Type

Features

- Universal Flange Mounting PN16 PN10 ASA150
- BS5155 (BS EN593)
- Lockable Handle
- Epoxy Coat Finish
- ISO 5211 Direct Mount

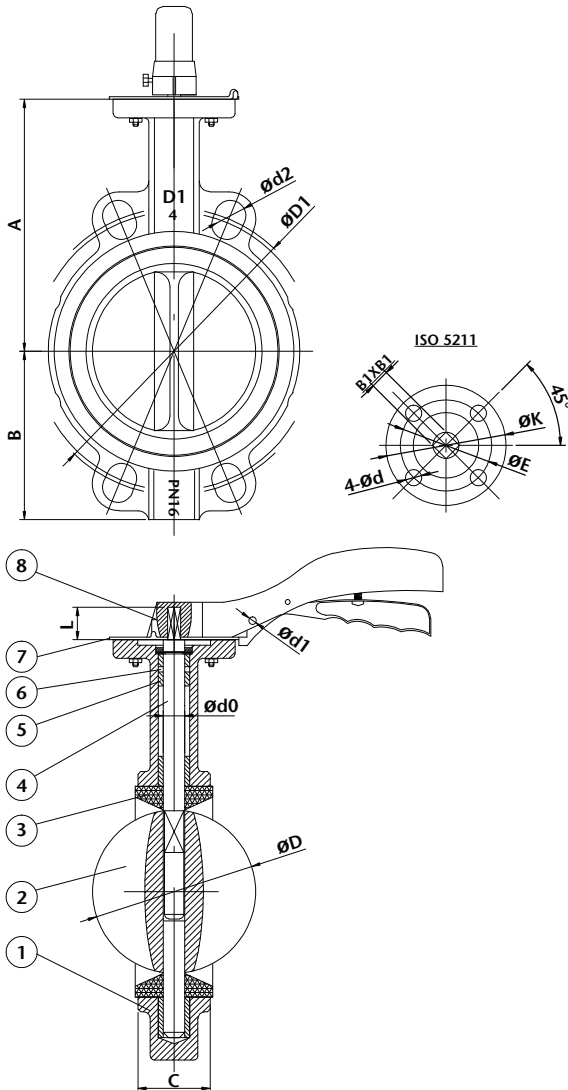

Pressure/Temperature

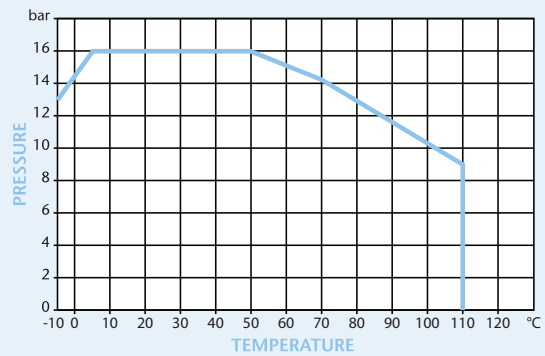

DN	2"	2 1/2"	3"	4"	5"	6"	8"	10"	12"
A	140	150	158	176	190	211	235	265	305
B	80	89	95	114	127	139	175	203	242
C	42	44.7	45.2	52	54.4	55.8	60.6	65.6	76.9
D	52.9	64.5	78.8	104	123.3	155.1	202.5	250.5	301.5
D1	125	145	160	180	210	240	295	355	410
L	26	26	26	30	30	30	36	36	36
d0	12.6	12.6	12.6	15.77	18.92	18.92	22.1	28.45	31.6
d1	6	6	6	6	6	6	6	6	6
d2	4x19	4x19	4x19	4x19	4x19	4x23	4x23	4x27	4x27
ISO 5211	F05	F05	F05	F07	F07	F07	F10	F10	F10
K	65	65	65	90	90	90	125	125	125
d	4x7	4x7	4x7	4x10	4x10	4x10	4x12	4x12	4x12
B1	9	9	9	11	14	14	17	22	22
Torque	15.1	17.2	23.1	39.8	61.9	102	192	323	490
Kgs	2.50	2.90	4.00	4.95	7.05	8.30	13.70	20.25	29.60

N.	Part Name	Materials
1	Body	Ductile Iron GGG40
2	Disc	Stainless Steel 316
3	Seat	EPDM
4	Stem	Stainless Steel 410
5	Bush	PTFE
6	O-Ring	EPDM
7	Indicator	Carbon Steel
8	Lever	Aluminium

We strongly advise gearbox on all 8", 10" and 12" valves.

Technical Data

Pressure 16 Bar

Working Temperature -10°C to +110°C

Dimensions in mm

This data sheet is designed as a guide and should not be regarded as wholly accurate in every detail. We reserve the right to amend the specification of any product without notice.

Ductile Iron Butterfly Valve Lugged & Tapped Type

Features

- Flange Mounting PN16 Only
- BS5155 (BS EN593)
- Lockable Handle
- Epoxy Coat Finish
- ISO 5211 Direct Mount

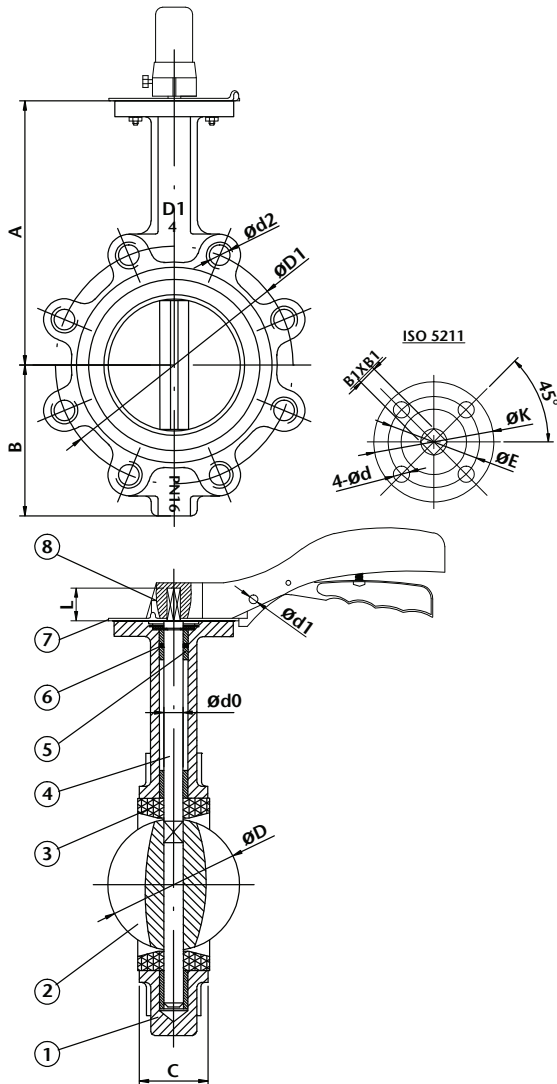

Pressure/Temperature

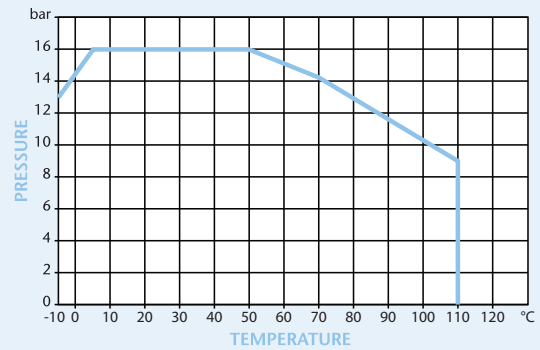

DN	2"	2 1/2"	3"	4"	5"	6"	8"	10"	12"
A	140	150	158	176	190	211	235	265	305
B	80	89	95	114	127	139	175	203	242
C	42	44.7	45.2	52	54.4	55.8	60.6	65.6	76.9
D	52.9	64.5	78.8	104	123.3	155.1	202.5	250.5	301.5
D1	125	145	160	180	210	240	295	355	410
L	26	26	26	30	30	30	36	36	36
d0	12.6	12.6	12.6	15.77	18.92	18.92	22.1	28.45	31.6
d1	6	6	6	6	6	6	6	6	6
d2	4x16	4x16	8x16	8x16	8x16	8x20	12x20	12x24	12x24
ISO 5211	F05	F05	F05	F07	F07	F07	F10	F10	F10
K	65	65	65	90	90	90	125	125	125
d	4x7	4x7	4x7	4x10	4x10	4x10	4x12	4x12	4x12
B1	9	9	9	11	14	14	17	22	22
Torque	15.1	17.2	23.1	39.8	61.9	102	192	323	490
Kgs	3.05	3.70	4.75	6.75	8.50	10.55	17.85	31.00	42.40

N.	Part Name	Materials
1	Body	Ductile Iron GGG40
2	Disc	Stainless Steel 316
3	Seat	EPDM
4	Stem	Stainless Steel 410
5	Bush	PTFE
6	O-Ring	EPDM
7	Indicator	Carbon Steel
8	Lever	Aluminium

We strongly advise gearbox on all 8", 10" and 12" valves.

Technical Data

Pressure 16 Bar

Working Temperature -10°C to +110°C

Dimensions in mm

This data sheet is designed as a guide and should not be regarded as wholly accurate in every detail. We reserve the right to amend the specification of any product without notice.

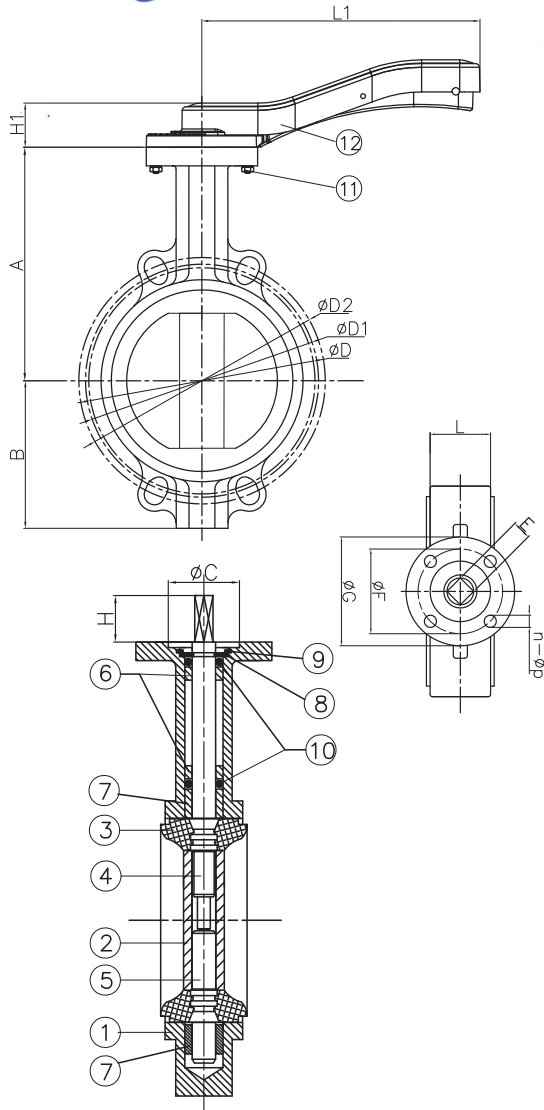

We strongly advise gearbox on all 8", 10" and 12" valves.

Technical Data

Maximum Pressure 16 Bar
Working Temperature -20°C to +110°C

Dimensions in mm

This data sheet is designed as a guide and should not be regarded as wholly accurate in every detail. We reserve the right to amend the specification of any product without notice.

Ductile Iron Butterfly Valve Wafer Type

Features

- Universal Flange Mounting PN10 PN16 ASA150
- BS5155 (BS EN 593)
- ISO 5211 Direct Mount
- Lockable Handle
- Epoxy Coat Finish

Pressure/Temperature

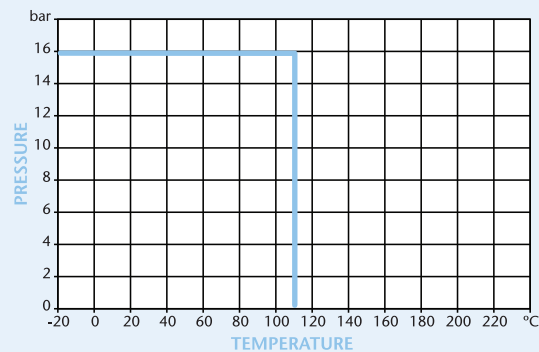

DN	50	65	80	100	125	150	200	250	300
A	142	154	161	179	193	204	250	282	326
B	60	78	87	105	120	138	174	209	242
C	56	56	56	56	56	56	71	71	71
D	125	145	160	180	210	240	295	355	410
E	11	11	11	11	14	14	17	22	22
F	70	70	70	70	70	70	102	102	102
G	90	90	90	90	90	90	125	125	125
H	19	19	19	19	19	19	25	30	30
H1	31	31	31	36	36	36	42	42	42
L	41.4	44	44.6	51.4	53.8	55.1	59.5	65	75.9
L1	176	176	176	225	225	225	300	359	359
Holes	4x19	4x19	8x19	8x19	8x19	8x23	12x23	12x28	12x28
n-Øp	4x10	4x10	4x10	4x10	4x10	4x10	4x12	4x12	4x12
Torque	19	21	28	43	60	91	194	295	412
Kgs	2.35	2.75	3.05	4.7	5.5	6.75	11.6	20.4	29.1

N.	Part Name	Materials
1	Body	Ductile Iron GGG40
2	Disc	Ductile Iron / Nickel Plated
3	Seat	EPDM
4	Upper Shaft	Stainless Steel 410
5	Lower Shaft	Stainless Steel 411
6	Short Bush	PTFE
7	Long Bush	PTFE
8	Split Pin	Spring Steel
9	Circlip	Spring Steel
10	O-Ring	EPDM
11	Bolt	Carbon Steel
12	Lever	DN 50-150 Aluminium DN200-300 DI

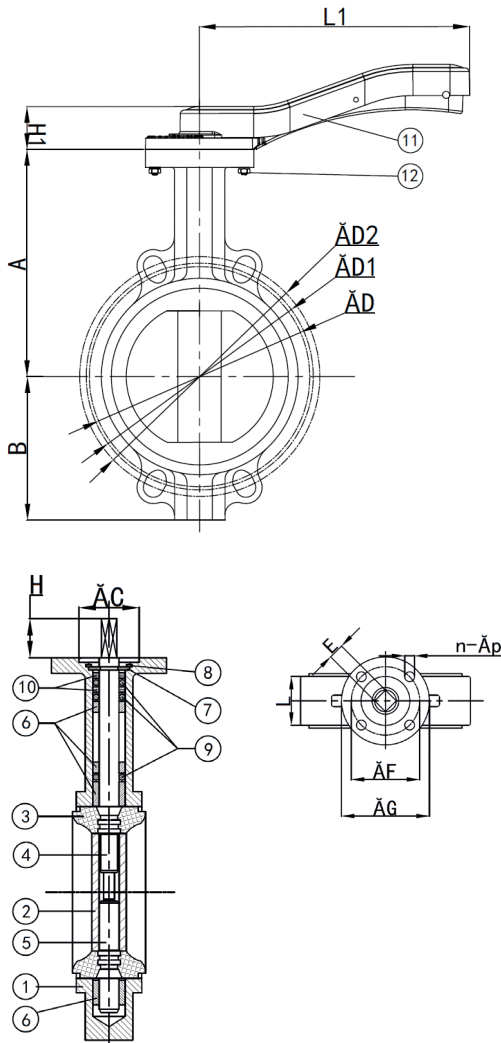

We strongly advise gearbox on all 8", 10" and 12" valves.

Technical Data

Maximum Pressure 16 Bar
Working Temperature -10°C to +110°C

Ductile Iron Butterfly Valve Wafer Type

Features

- Universal Flange Mounting PN10 PN16 ASA150
- BS5155 (BS EN 593) / ANSI 150
- ISO 5211 Direct Mount
- Lockable Handle
- Epoxy Coat Finish
- WRAS Approved
- MSS-SP-67

Pressure/Temperature

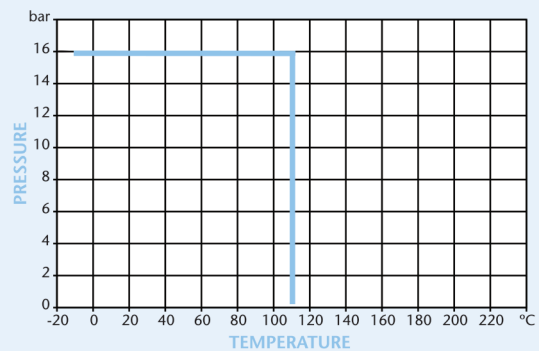

	50	65	80	100	125	150	200	250	300
A	142	154.5	161	180	193	205	250	282	326
B	60	70	85	104	120	135	171	205	248
C	56	56	56	56	56	56	71	71	71
D	125	145	160	180	210	240	295	350	400
D1	125	145	160	180	210	240	295	355	410
D2	120.65	139.7	152.4	190.5	215.9	241.3	298.45	361.95	431.8
E	11	11	11	11	14	14	17	22	22
F	70	70	70	70	70	70	102	102	102
G	90	90	90	90	90	90	125	125	125
H	19	19	19	19	19	19	25	30	30
H1	31	31	31	36	36	36	42	42	42
L	41.4	44	44.6	51.4	53.8	55.1	59.5	65	75.9
L1	176	176	176	225	225	225	300	359	359
Holes PN10	4-19	4-19	8-19	8-19	8-19	8-23	8-23	12-23	12-23
Holes PN16	4x19	4x19	8x19	8x19	8x19	8x23	12x23	12x28	12x28
Holes CLASS	4-	4-	4-	8-	8-	8-	8-	12-	12-
150	19.05	19.05	19.05	19.05	22.35	22.35	22.35	25.4	25.4
n-Øp	4x10	4x10	4x10	4x10	4x10	4x10	4x12	4x12	4x12
Torque	19	21	28	43	60	91	194	295	412
Kgs	2.35	2.75	3.05	4.7	5.5	6.75	11.6	20.4	29.1

N.	Part Name	Materials
1	Body	Ductile Iron GGG40
2	Disc	Stainless Steel 316
3	Seat	WRAS EPDM
4	Upper Shaft	Stainless Steel 420
5	Lower Shaft	Stainless Steel 420
6	Bushing	PTFE
7	Split Pin	Spring Steel 65Mn
8	Circlip	Spring Steel 65Mn
9	O-Ring	WRAS EPDM
10	Ring	Nylon 6 PA6
11	Lever	DN50-150 Aluminium DN200-300 DI
12	Bolt	Stainless Steel 304

Dimensions in mm

This data sheet is designed as a guide and should not be regarded as wholly accurate in every detail. We reserve the right to amend the specification of any product without notice.

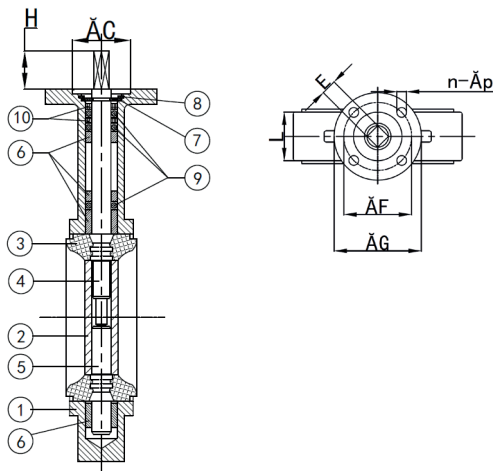
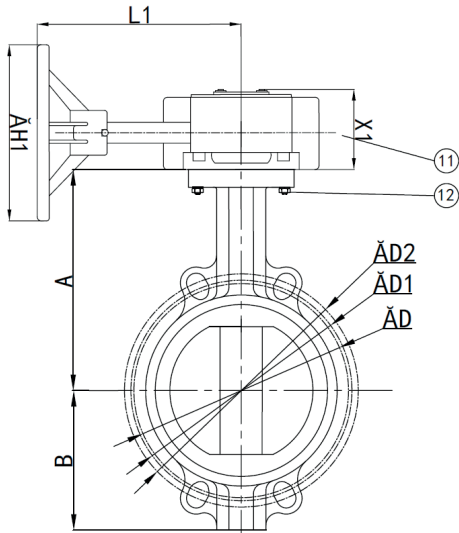

Ductile Iron Butterfly Valve Wafer Type with gearbox

Features

- Universal Flange Mounting PN10 PN16 ASA150
- BS5155 (BS EN 593) / ANSI 150
- ISO 5211 Direct Mount
- Epoxy Coat Finish
- WRAS Approved
- MSS-SP-67

Pressure/Temperature

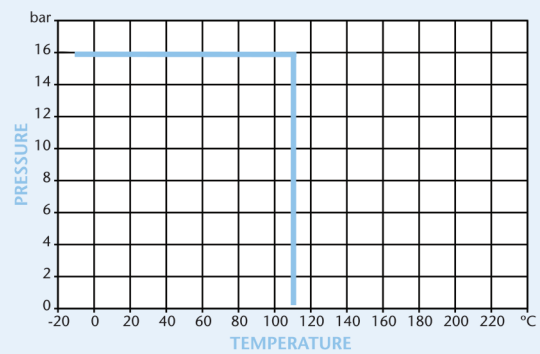

	50	65	80	100	125	150	200	250	300
A	142	154.5	161	180	193	205	250	282	326
B	60	70	85	104	120	135	171	205	248
C	56	56	56	56	56	56	71	71	71
D	125	145	160	180	210	240	295	350	400
D1	125	145	160	180	210	240	295	355	410
D2	120.65	139.7	152.4	190.5	215.9	241.3	298.45	361.95	431.8
E	11	11	11	11	14	14	17	22	22
F	70	70	70	70	70	70	102	102	102
G	90	90	90	90	90	90	125	125	125
H	19	19	19	19	19	19	25	30	30
H1	134	134	134	134	134	134	215	215	215
L	41.4	44	44.6	51.4	53.8	55.1	59.5	65	75.9
L1	145	145	145	145	145	145	216	216	216
Holes PN10	4-19	4-19	8-19	8-19	8-19	8-23	8-23	12-23	12-23
Holes PN16	4x19	4x19	8x19	8x19	8x19	8x23	12x23	12x28	12x28
Holes	4-	4-	4-	8-	8-	8-	8-	12-	12-
CLASS 150	19.05	19.05	19.05	19.05	22.35	22.35	22.35	25.4	25.4
X1	62	62	62	62	62	62	71	71	71
n-Øp	4x10	4x10	4x10	4x10	4x10	4x10	4x12	4x12	4x12
Kgs	5.35	5.75	6.05	7.7	8.5	9.75	17.6	26.4	35.1

N.	Part Name	Materials
1	Body	Ductile Iron GGG40
2	Disc	Stainless Steel 316
3	Seat	WRAS EPDM
4	Upper Shaft	Stainless Steel 420
5	Lower Shaft	Stainless Steel 420
6	Bushing	PTFE
7	Split Pin	Spring Steel 65Mn
8	Circlip	Spring Steel 65Mn
9	O-Ring	WRAS EPDM
10	Ring	Nylon 6 PA6
11	Gear Box	Aluminium AL102
12	Bolt	Stainless Steel 304

Technical Data

Maximum Pressure 16 Bar
Working Temperature -10°C to +110°C

Dimensions in mm

This data sheet is designed as a guide and should not be regarded as wholly accurate in every detail. We reserve the right to amend the specification of any product without notice.

Ductile Iron Butterfly Valve Wafer Type with gearbox

Features

- Universal Flange Mounting PN10 PN16 ASA150
- BS5155 (BS EN 593) / ANSI 150
- ISO 5211 Direct Mount
- Epoxy Coat Finish
- MSS-SP-67

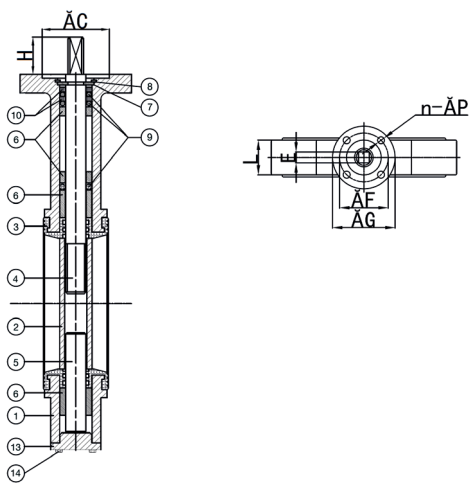
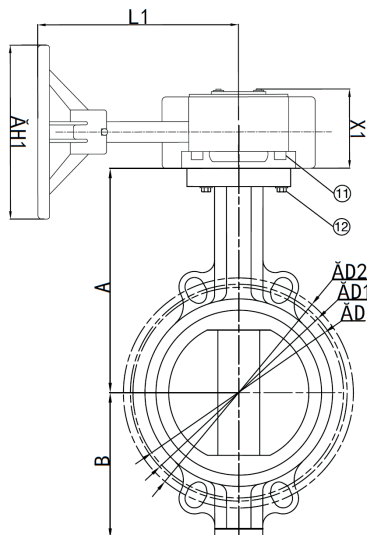

NOTE: DN350 without back cover and back cover bolts.

Technical Data

Maximum Pressure	16 Bar
Working Temperature	-10°C to +110°C

Dimensions in mm

This data sheet is designed as a guide and should not be regarded as wholly accurate in every detail. We reserve the right to amend the specification of any product without notice.

Pressure/Temperature

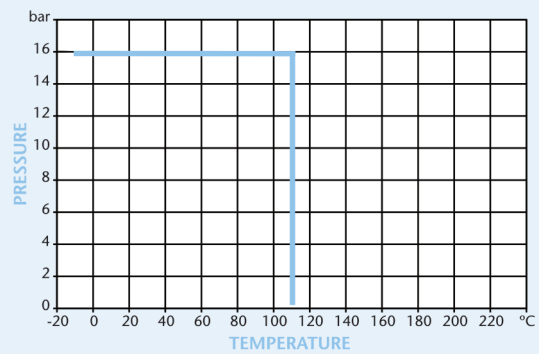

	350	400	450	500	600
A	345	390	422	470	552
B	262	305	341	373	445
C	71	100.5	100.5	100.5	130.5
D	460	515	565	620	725
D1	470	525	585	650	770
D2	476.25	539.75	577.85	635	749.3
E	22	27	27	27	36
ÄF	102	140	140	140	165
ÄG	125	175	175	175	210
H	40	52	52	64	70
H1	300	300	300	300	300
L	78	102	114	127	154
L1	225	131	131	131	138
Holes PN10	16-Ä23	16-Ä28	20-Ä28	20-Ä28	20-Ä31
Holes PN16	16-Ä28	16-Ä31	20-Ä31	20-Ä34	20-Ä37
Holes CLASS 150	12-Ä28.45	16-Ä28.45	16-Ä31.75	20-Ä31.75	20-35.05
X1	84	264	264	269	307
n-Øp	4-12	4-18	4-18	4-18	4-23
Torque (N.M)	840	1260	2070	2670	5295
Kgs	62	121.7	134	162.6	236.4

N.	Part Name	Materials
1	Body	Ductile Iron GGG40
2	Disc	Stainless Steel 316
3	Seat	WRAS EPDM
4	Upper Shaft	Stainless Steel 420
5	Lower Shaft	Stainless Steel 420
6	Bushing	PTFE
7	Split Pin	Spring Steel 65Mn
8	Circlip	Spring Steel 65Mn
9	O-Ring	WRAS EPDM
10	Ring	Nylon 6 PA6
11	Gear Box	Aluminium AL102
12	Bolt	Stainless Steel 304



PN25 Ductile Iron Butterfly Valve Wafer Type

Features

- Flange Mounting PN25 Only
- BS5155 (BS EN 593)
- ISO 5211 Direct Mount
- Lockable Handle
- Epoxy Coat Finish
- Vulcanised Liner

Pressure/Temperature

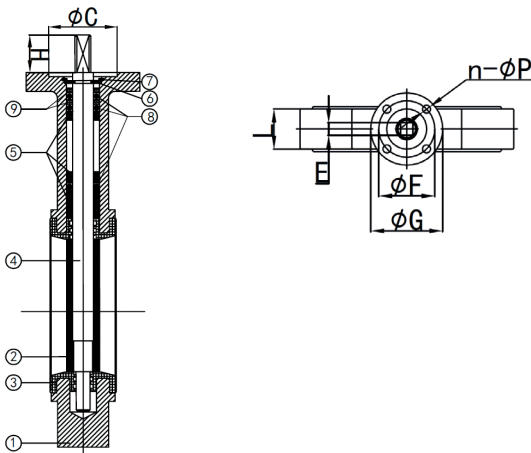
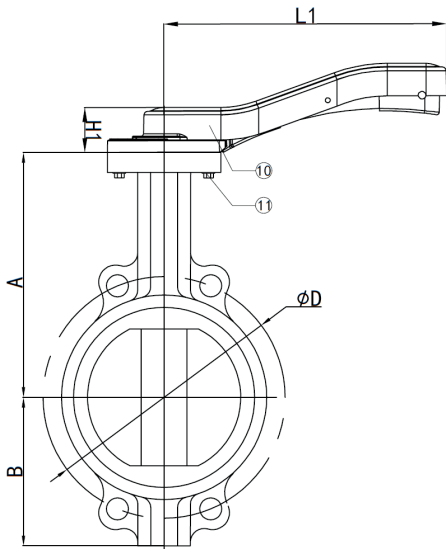
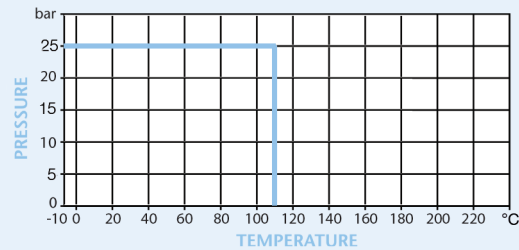

DN	50	65	80	100	125	150
A	141	153	161	178	193	204
B	61	72	87	106	123	138
C	56	56	56	56	56	56
D	125	145	160	190	220	250
E	11	11	11	11	14	14
F	70	70	70	70	70	70
G	90	90	90	90	90	90
L	43	46	46	52	56	56
n-Øp	4-10	4-10	4-10	4-10	4-10	4-10
H	19	19	19	19	19	19
H1	31	31	31	36	36	36
L1	176	176	176	225	225	225
Torque	22	26	36	73	90	106
Kgs	3.5	4.3	5	7	10	12.5

N.	Part Name	Materials
1	Body	Ductile Iron GGG40
2	Disc	Stainless Steel 316
3	Seat	EPDM
4	Shaft	Stainless Steel 431
5	Bushing	Brass H65
6	Cotter Pin	Spring Steel 65Mn
7	Circlip	Spring Steel 65Mn
8	O-Ring	NBR
9	Ring	Nylon 6 PA6
10	Handle	AL102
11	Bolt	Stainless Steel 304

We strongly advise gearbox on all 8", 10" and 12" valves.

Technical Data

Max Pressure	25 Bar
Working Temperature	-10°C to +110°C

Dimensions in mm

This data sheet is designed as a guide and should not be regarded as wholly accurate in every detail. We reserve the right to amend the specification of any product without notice.



PN25 Ductile Iron Butterfly Valve Wafer Type

Features

- Flange Mounting PN25 Only
- BS5155 (BS EN 593)
- ISO 5211 Direct Mount
- Epoxy Coat Finish
- Vulcanised Liner

Pressure/Temperature

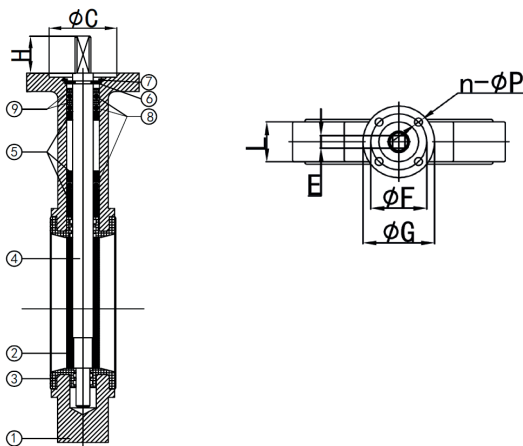
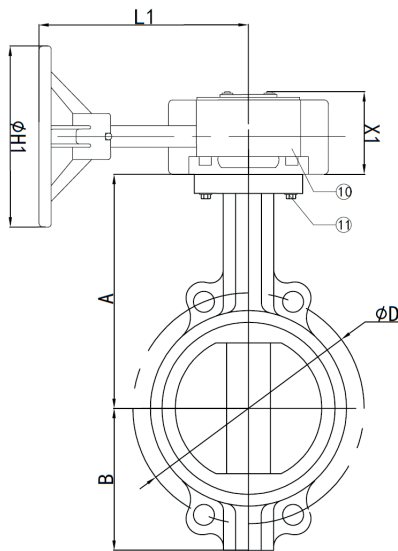
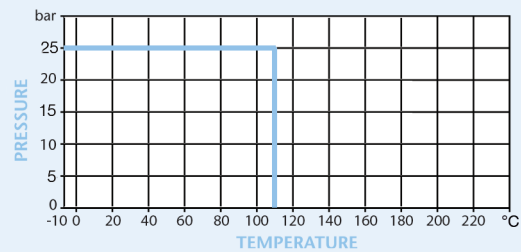

DN	200	250	300
A	247	280	324
B	173	207	250
C	71	71	71
D	310	370	430
E	17	22	22
F	102	102	102
G	125	125	125
L	60	68	78
n-Øp	4-12	4-12	4-12
H	25	30	30
H1	215	215	215
L1	216	216	216
X1	71	71	71
Torque	290	400	510
Kgs	24	34	45

Technical Data

Max Pressure 25 Bar
Working Temperature -10°C to +110°C

N.	Part Name	Materials
1	Body	Ductile Iron GGG40
2	Disc	Stainless Steel 316
3	Seat	EPDM
4	Shaft	Stainless Steel 431
5	Bushing	Brass H65
6	Cotter Pin	Spring Steel 65Mn
7	Circlip	Spring Steel 65Mn
8	O-Ring	NBR
9	Ring	Nylon 6 PA6
10	Gearbox	AL102
11	Bolt	Stainless Steel 304

Dimensions in mm

This data sheet is designed as a guide and should not be regarded as wholly accurate in every detail. We reserve the right to amend the specification of any product without notice.

Ductile Iron Butterfly Valve Wafer Type

Features

- Universal Flange Mounting PN10 PN16 ASA150
- BS5155 (BS EN 593)
- ISO 5211 Direct Mount
- Lockable Handle
- Epoxy Coat Finish

Pressure/Temperature

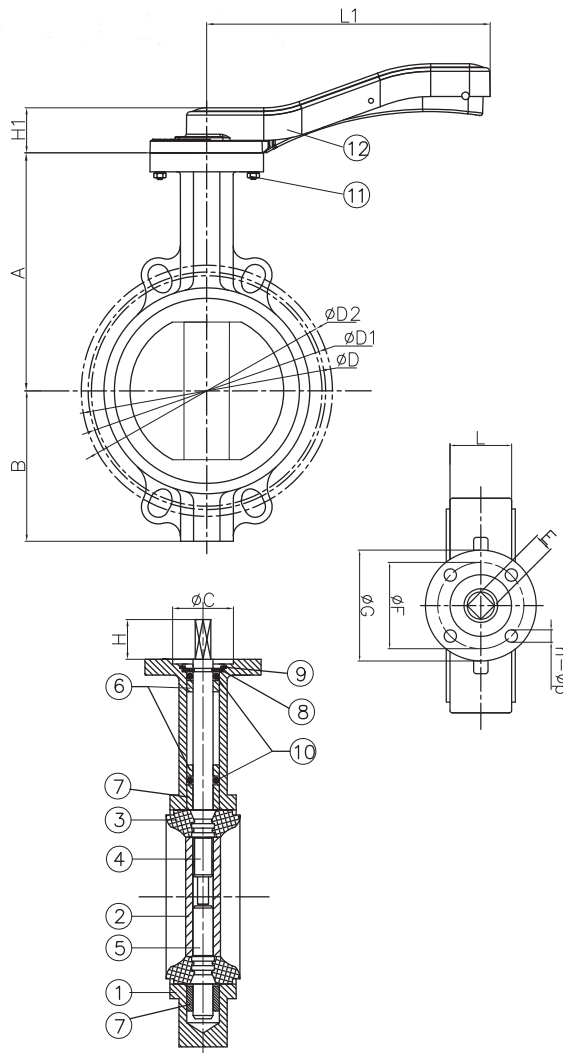
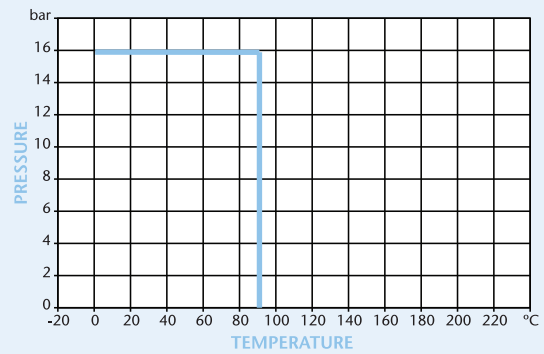

We strongly advise gearbox on all 8", 10" and 12" valves.

Technical Data

Maximum Pressure 16 Bar
Working Temperature -0°C to +90°C

Dimensions in mm

This data sheet is designed as a guide and should not be regarded as wholly accurate in every detail. We reserve the right to amend the specification of any product without notice.

DN	50	65	80	100	125	150	200	250	300
A	142	154	161	179	193	204	250	282	326
B	60	78	87	105	120	138	174	209	242
C	56	56	56	56	56	56	71	71	71
D	125	145	160	180	210	240	295	355	410
E	11	11	11	11	14	14	17	22	22
F	70	70	70	70	70	70	102	102	102
G	90	90	90	90	90	90	125	125	125
H	19	19	19	19	19	19	25	30	30
H1	31	31	31	36	36	36	42	42	42
L	41.4	44	44.6	51.4	53.8	55.1	59.5	65	75.9
L1	176	176	176	225	225	225	300	359	359
Holes	4x19	4x19	8x19	8x19	8x19	8x23	12x23	12x28	12x28
n-Øp	4x10	4x10	4x10	4x10	4x10	4x10	4x12	4x12	4x12
Torque	19	21	28	43	60	91	194	295	412
Kgs	2.35	2.75	3.05	4.7	5.5	6.75	11.6	20.4	29.1

N.	Part Name	Materials
1	Body	Ductile Iron GGG40
2	Disc	Stainless Steel 316
3	Seat	NBR
4	Upper Shaft	Stainless Steel 410
5	Lower Shaft	Stainless Steel 411
6	Short Bush	PTFE
7	Long Bush	PTFE
8	Split Pin	Spring Steel
9	Circlip	Spring Steel
10	O-Ring	EPDM
11	Bolt	Carbon Steel
12	Lever	DN 50-150 Aluminium DN200-300 DI



Ductile Iron Butterfly Valve Lugged & Tapped Type

Features

- Flange Mounting PN16 Only
- BS5155 (BS EN 593)
- ISO 5211 Direct Mount
- Lockable Handle
- Epoxy Coat Finish
- WRAS Approved
- MSS-SP-67

Pressure/Temperature

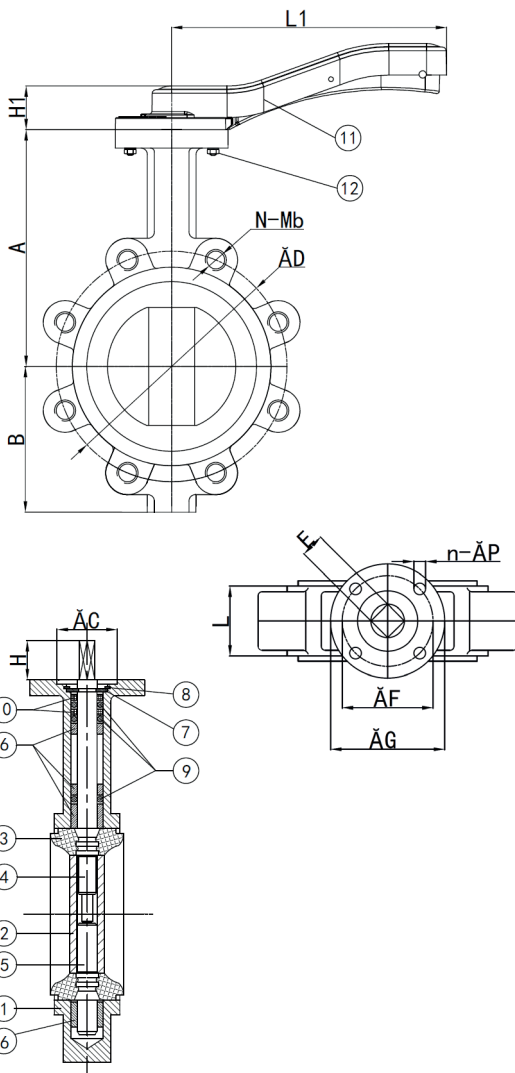
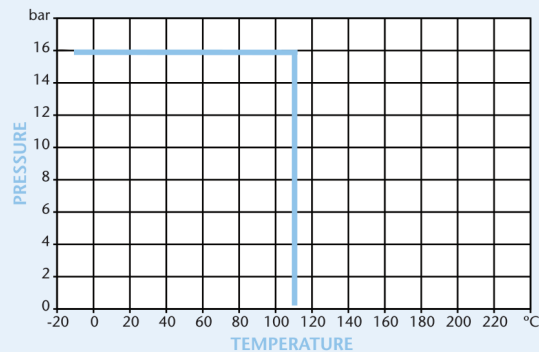

We strongly advise gearbox on all 8", 10" and 12" valves.

Technical Data

Maximum Pressure	16 Bar
Working Temperature	-10°C to +110°C

Dimensions in mm

This data sheet is designed as a guide and should not be regarded as wholly accurate in every detail. We reserve the right to amend the specification of any product without notice.

	50	65	80	100	125	150	200	250	300
A	142	154.5	161	180	193	205	250	282	326
B	60	70	85	104	120	135	171	205	248
C	56	56	56	56	56	56	71	71	71
D1	125	145	160	180	210	240	295	355	410
E	11	11	11	11	14	14	17	22	22
F	70	70	70	70	70	70	102	102	102
G	90	90	90	90	90	90	125	125	125
H	19	19	19	19	19	19	25	30	30
H1	31	31	31	36	36	36	42	42	42
L	41.4	44	44.6	51.4	53.8	55.1	59.5	65	75.9
L1	176	176	176	225	225	225	300	359	359
N-Mb	4-M16	4-M16	8-M16	8-M16	8-M16	8-M20	12-M20	12-M24	12-M24
n-AP	4x10	4x10	4x10	4x10	4x10	4x10	4x12	4x12	4x12
Torque	19	21	28	43	60	91	194	295	412
Kgs	2.35	2.75	3.05	4.7	5.5	6.75	11.6	20.4	29.1

N.	Part Name	Materials
1	Body	Ductile Iron GGG40
2	Disc	Stainless Steel 316
3	Seat	WRAS EPDM
4	Upper Shaft	Stainless Steel 420
5	Lower Shaft	Stainless Steel 420
6	Bushing	PTFE
7	Split Pin	Spring Steel 65Mn
8	Circlip	Spring Steel 65Mn
9	O-Ring	WRAS EPDM
10	Ring	Nylon 6 PA6
11	Lever	DN50-150 Aluminium DN200-300 DI
12	Bolt	Stainless Steel 304

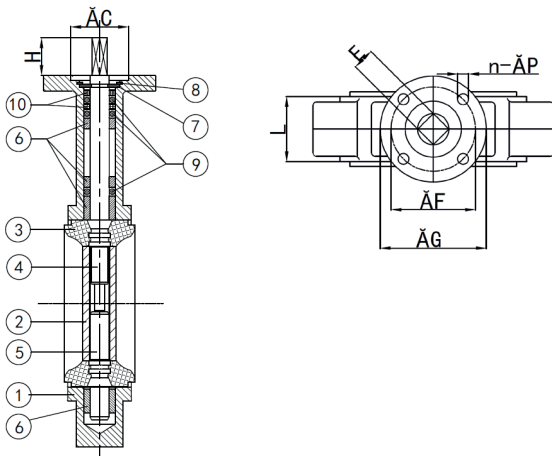
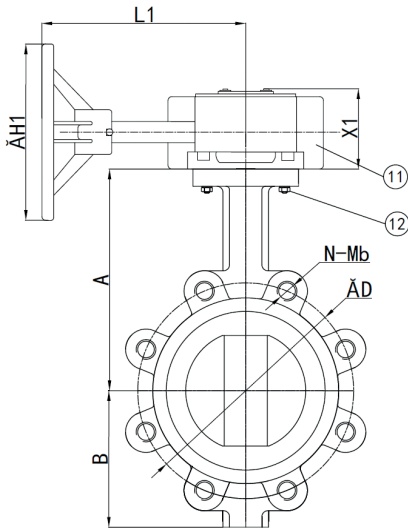

We strongly advise gearbox on all 8", 10" and 12" valves.

PN16 Ductile Iron Butterfly Valve Lugged & Tapped Type

Features

- Flange Mounting PN16 Only
- BS5155 (BS EN 593)
- ISO 5211 Direct Mount
- Epoxy Coat Finish
- WRAS Approved
- MSS-SP-67

Pressure/Temperature

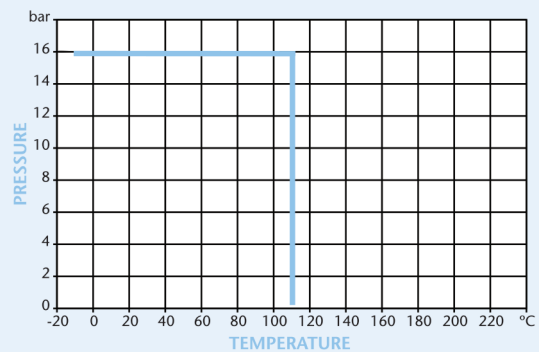

	50	65	80	100	125	150	200	250	300
A	142	154.5	161	180	193	205	250	282	326
B	60	70	85	104	120	135	171	205	248
C	56	56	56	56	56	56	71	71	71
D1	125	145	160	180	210	240	295	355	410
E	11	11	11	11	14	14	17	22	22
F	70	70	70	70	70	70	102	102	102
G	90	90	90	90	90	90	125	125	125
H	19	19	19	19	19	19	25	30	30
H1	134	134	134	134	134	134	215	215	215
L	41.4	44	44.6	51.4	53.8	55.1	59.5	65	75.9
L1	145	145	145	145	145	145	216	216	216
X1	62	62	62	62	62	62	71	71	71
N-Mb	4-M16	4-M16	8-M16	8-M16	8-M16	8-M20	12-M20	12-M24	12-M24
n-Äp	4x10	4x10	4x10	4x10	4x10	4x10	4x12	4x12	4x12
Kgs	5.35	5.75	6.05	7.7	8.5	9.75	17.6	26.4	35.1

N.	Part Name	Materials
1	Body	Ductile Iron GGG40
2	Disc	Stainless Steel 316
3	Seat	WRAS EPDM
4	Upper Shaft	Stainless Steel 420
5	Lower Shaft	Stainless Steel 420
6	Bushing	PTFE
7	Split Pin	Spring Steel 65Mn
8	Circlip	Spring Steel 65Mn
9	O-Ring	WRAS EPDM
10	Ring	Nylon 6 PA6
11	Gearbox	Aluminium
12	Bolt	Stainless Steel 304

Technical Data

Maximum Pressure 16 Bar
Working Temperature -10°C to +110°C

Dimensions in mm

This data sheet is designed as a guide and should not be regarded as wholly accurate in every detail. We reserve the right to amend the specification of any product without notice.

PN16 Ductile Iron Butterfly Valve Lugged & Tapped Type

Features

- Flange Mounting PN16 Only
- BS5155 (BS EN 593)
- ISO 5211 Direct Mount
- Epoxy Coat Finish
- MSS-SP-67

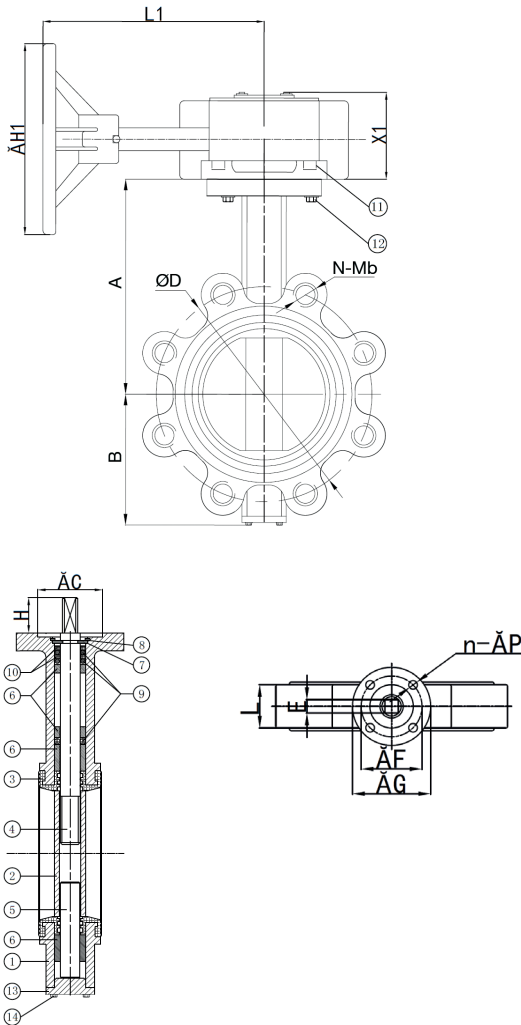

Pressure/Temperature

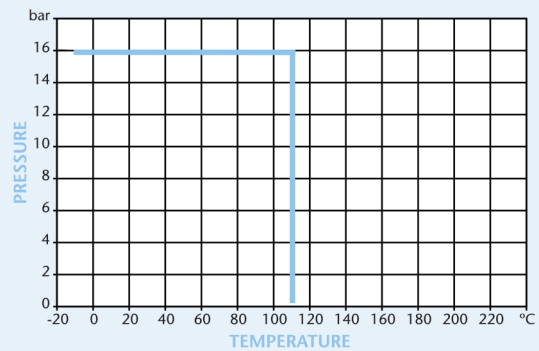

	350	400	450	500	600
ÅD	470	525	585	650	770
N-Mb	16-M24	16-M27	20-M27	20-M30	20-M33
A	345	390	422	470	552
B	262	305	341	373	445
C	71	100.5	100.5	100.5	130.5
H	40	52	52	64	70
ÅG	125	175	175	175	210
n-ÅP	4-12	4-18	4-18	4-18	4-23
ÅF	102	140	140	140	165
L	78	102	114	127	154
E	22	27	27	27	36
H1	300	300	300	300	300
L1	225	131	131	131	138
X1	84	264	264	269	307
Torque (N.M)	840	1260	2070	2670	5295
Kgs	88	168	198	238.8	334.8

N.	Part Name	Materials
1	Body	Ductile Iron GGG40
2	Disc	Stainless Steel 316
3	Seat	WRAS EPDM
4	Upper Shaft	Stainless Steel 431
5	Lower Shaft	Stainless Steel 431
6	Bushing	Brass H65
7	Split Pin	Spring Steel 65Mn
8	Circlip	Spring Steel 65Mn
9	O-Ring	WRAS EPDM
10	Ring	Nylon 6 PA6
11	Gearbox	Ductile Iron
12	Bolt	Stainless Steel 304
13	End Cover	Ductile Iron GGG40
14	Bolt	Stainless Steel 304

NOTE: DN350 without back cover and back cover bolts.

Technical Data

Maximum Pressure 16 Bar
Working Temperature -10°C to +110°C

Dimensions in mm

This data sheet is designed as a guide and should not be regarded as wholly accurate in every detail. We reserve the right to amend the specification of any product without notice.

ANSI 150 Ductile Iron Butterfly Valve Lugged & Tapped Type

Features

- Flange Mounting ANSI Class 150
- BS5155 (BS EN 593)
- ISO 5211 Direct Mount
- Lockable Handle
- Epoxy Coat Finish
- WRAS Approved
- MSS-SP-67

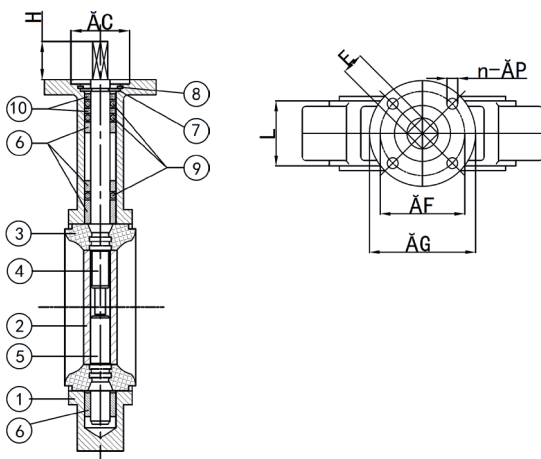
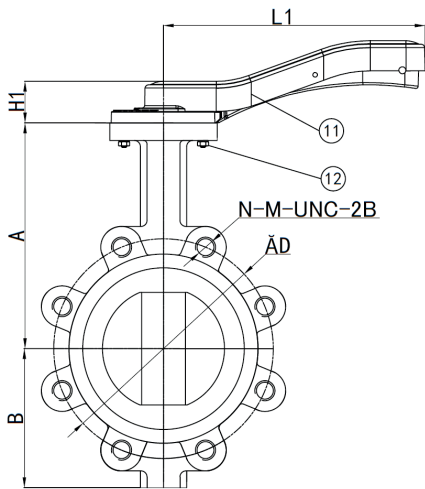

Pressure/Temperature

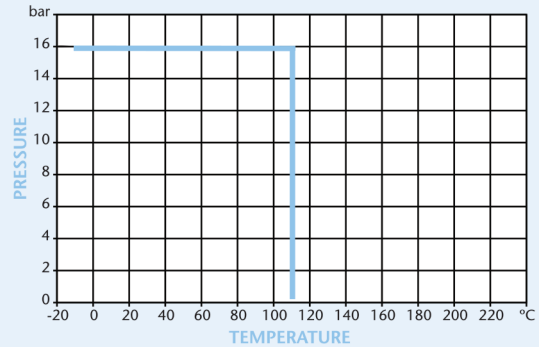

	50	65	80	100	125	150	200	250	300
A	142	154.5	161	180	193	205	250	282	326
B	60	70	85	104	120	135	171	205	248
C	56	56	56	56	56	56	71	71	71
D	120.65	139.7	152.4	190.5	215.9	241.3	298.45	361.95	431.8
E	11	11	11	11	14	14	17	22	22
F	70	70	70	70	70	70	102	102	102
G	90	90	90	90	90	90	125	125	125
H	19	19	19	19	19	19	25	30	30
H1	31	31	31	36	36	36	42	42	42
L	41.4	44	44.6	51.4	53.8	55.1	59.5	65	75.9
L1	176	176	176	225	225	225	300	359	359
N-M-UNC-2B	4-5/ 8-11 UNC -2B	4-5/ 8-11 UNC -2B	4-5/ 8-11 UNC -2B	8-5/ 8-11 UNC -2B	8-3/ 4-10 UNC -2B	8-3/ 4-10 UNC -2B	8-3/ 4-10 UNC -2B	12-7/ 8-9 UNC -2B	12-7/ 8-9 UNC -2B
n-Äp	4x10	4x10	4x10	4x10	4x10	4x10	4x12	4x12	4x12
Kgs	2.35	2.75	3.05	4.7	5.5	6.75	11.6	20.4	29.1

N.	Part Name	Materials
1	Body	Ductile Iron GGG40
2	Disc	Stainless Steel 316
3	Seat	WRAS EPDM
4	Upper Shaft	Stainless Steel 420
5	Lower Shaft	Stainless Steel 420
6	Bushing	PTFE
7	Split Pin	Spring Steel 65Mn
8	Circlip	Spring Steel 65Mn
9	O-Ring	WRAS EPDM
10	Ring	Nylon 6 PA6
11	Lever	DN50-150 Aluminium DN200-300 DI
12	Bolt	Stainless Steel 304

We strongly advise gearbox on all 8", 10" and 12" valves.

Technical Data

Maximum Pressure	16 Bar
Working Temperature	-10°C to +110°C

Dimensions in mm

This data sheet is designed as a guide and should not be regarded as wholly accurate in every detail. We reserve the right to amend the specification of any product without notice.

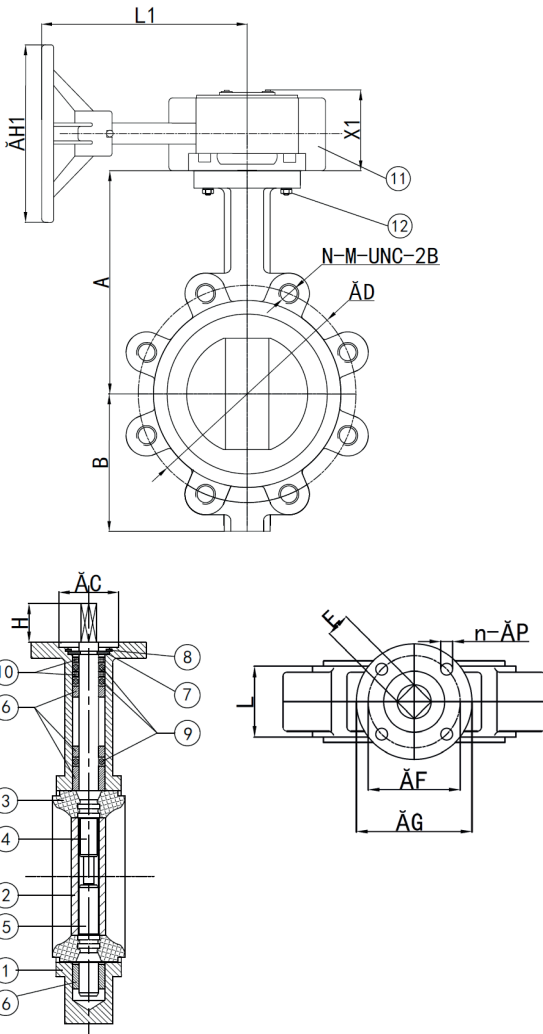

ANSI 150 Ductile Iron Butterfly Valve Lugged & Tapped Type

Features

- Flange Mounting ANSI Class 150
- BS5155 (BS EN 593)
- ISO 5211 Direct Mount
- Epoxy Coat Finish
- WRAS Approved
- MSS-SP-67

Pressure/Temperature

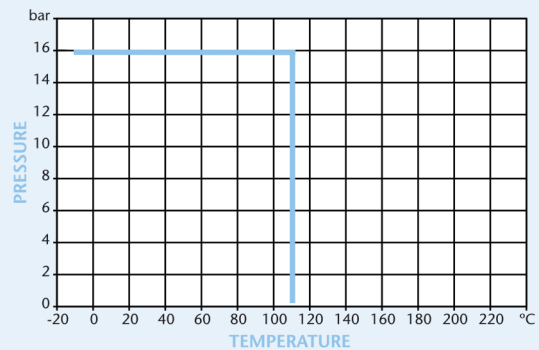

	50	65	80	100	125	150	200	250	300
A	142	154.5	161	180	193	205	250	282	326
B	60	70	85	104	120	135	171	205	248
C	56	56	56	56	56	56	71	71	71
D1	125	145	160	180	210	240	295	355	410
	4-5/ 8-11	4-5/ 8-11	4-5/ 8-11	8-5/ 8-11	8-3/ 4-10	8-3/ 4-10	8-3/ 4-10	12-7/ 8-9	12-7/ 8-9
N-M- UNC-2B	UNC -2B	UNC -2B	UNC -2B	UNC -2B	UNC -2B	UNC -2B	UNC -2B	UNC -2B	UNC -2B
E	11	11	11	11	14	14	17	22	22
F	70	70	70	70	70	70	102	102	102
G	90	90	90	90	90	90	125	125	125
L	41.4	44	44.6	51.4	53.8	55.1	59.5	65	75.9
n-Äp	4-10	4-10	4-10	4-10	4-10	4-10	4-12	4-12	4-12
H	19	19	19	19	19	19	25	30	30
H1	134	134	134	134	134	134	215	215	215
L1	145	145	145	145	145	145	216	216	216
X1	62	62	62	62	62	62	71	71	71
Kgs	5.35	5.75	6.05	7.7	8.5	9.75	17.6	26.4	35.1

N.	Part Name	Materials
1	Body	Ductile Iron GGG40
2	Disc	Stainless Steel 316
3	Seat	WRAS EPDM
4	Upper Shaft	Stainless Steel 420
5	Lower Shaft	Stainless Steel 420
6	Bushing	PTFE
7	Split Pin	Spring Steel 65Mn
8	Circlip	Spring Steel 65Mn
9	O-Ring	WRAS EPDM
10	Ring	Nylon 6 PA6
11	Gearbox	Aluminium AL102
12	Bolt	Stainless Steel 304

We strongly advise gearbox on all 8", 10" and 12" valves.

Technical Data

Maximum Pressure 16 Bar
Working Temperature -10°C to +110°C

Dimensions in mm

This data sheet is designed as a guide and should not be regarded as wholly accurate in every detail. We reserve the right to amend the specification of any product without notice.

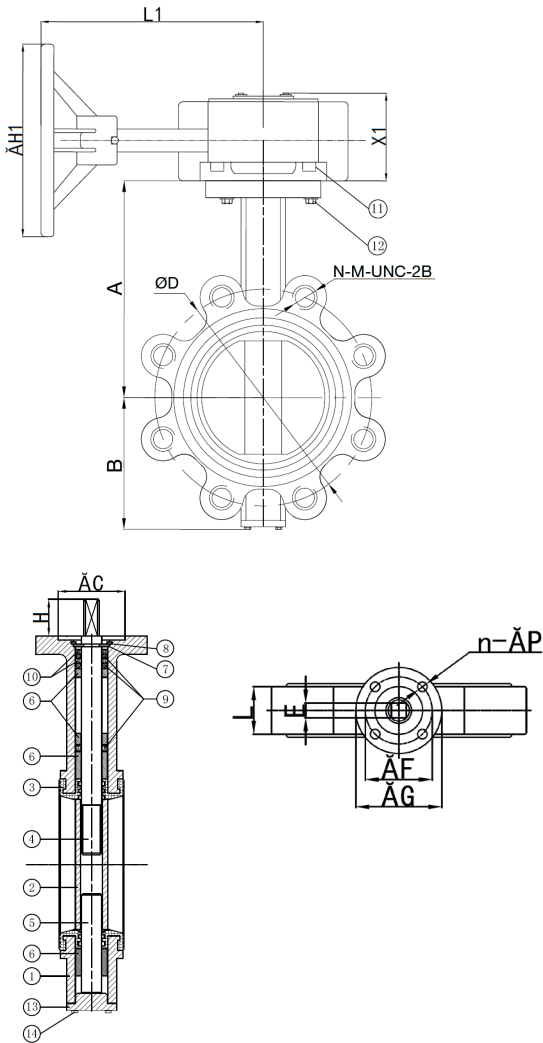

ANSI 150 Ductile Iron Butterfly Valve Lugged & Tapped Type

Features

- Flange Mounting ANSI Class 150
- BS5155 (BS EN 593)
- ISO 5211 Direct Mount
- Epoxy Coat Finish
- MSS-SP-67

Pressure/Temperature

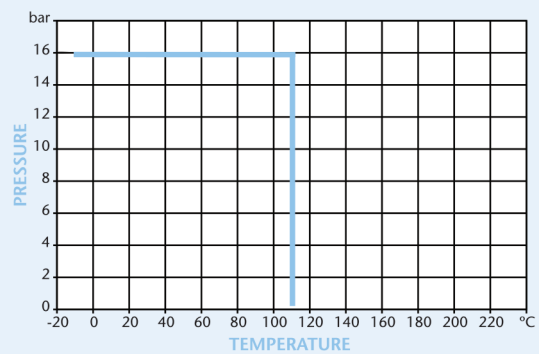

	350	400	450	500	600
ÄD	476.25	539.75	577.85	635	749.3
N-M-UNC-2B	12-1-8UNC-2B	16-1-8UNC-2B	16-1.1/8-7UNC-2B	20-1.1/8-7UNC-2B	20-1.1/4-7UNC-2B
A	345	390	422	470	552
B	262	305	341	373	445
C	71	100.5	100.5	100.5	130.5
H	40	52	52	64	70
ÄG	125	175	175	175	210
n-ÄP	4-12	4-18	4-18	4-18	4-23
ÄF	102	140	140	140	165
L	78	102	114	127	154
E	22	27	27	27	36
H1	300	300	300	300	300
L1	225	131	131	131	138
X1	84	264	264	296	307
Torque (N.M)	840	1260	2070	2670	5295
Kgs	88	168	198	238.8	334.8

N.	Part Name	Materials
1	Body	Ductile Iron GGG40
2	Disc	Stainless Steel 316
3	Seat	WRAS EPDM
4	Upper Shaft	Stainless Steel 420
5	Lower Shaft	Stainless Steel 420
6	Bushing	PTFE
7	Split Pin	Spring Steel 65Mn
8	Circlip	Spring Steel 65Mn
9	O-Ring	WRAS EPDM
10	Ring	Nylon 6 PA6
11	Gearbox	Aluminium AL102
12	Bolt	Stainless Steel 304

Technical Data

Maximum Pressure 16 Bar
Working Temperature -10°C to +110°C

Dimensions in mm

This data sheet is designed as a guide and should not be regarded as wholly accurate in every detail. We reserve the right to amend the specification of any product without notice.



PN25 Ductile Iron Butterfly Valve Lugged & Tapped Type

Features

- Flange Mounting PN25 Only
- BS5155 (BS EN 593)
- ISO 5211 Direct Mount
- Lockable Handle
- Epoxy Coat Finish
- Vulcanised Liner

Pressure/Temperature

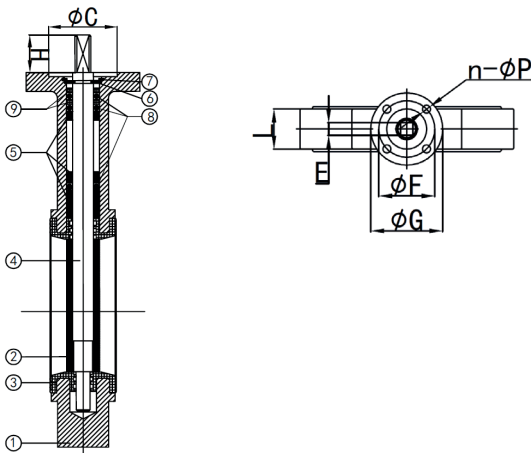
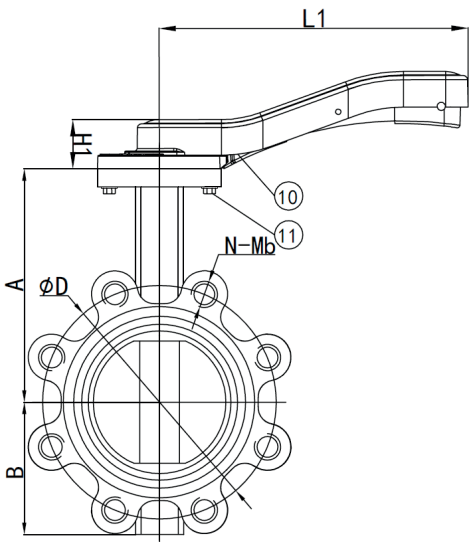
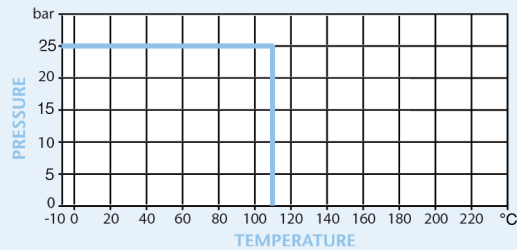

We strongly advise gearbox on all 8", 10" and 12" valves.

Technical Data

Max Pressure	25 Bar
Working Temperature	-10°C to +110°C

Dimensions in mm

This data sheet is designed as a guide and should not be regarded as wholly accurate in every detail. We reserve the right to amend the specification of any product without notice.

DN	50	65	80	100	125	150
A	141	153	161	178	193	204
B	61	72	87	106	123	138
C	56	56	56	56	56	56
D	125	145	160	190	220	250
N-Mb	4-M16	8-M16	8-M16	8-M20	8-M24	8-M24
E	11	11	11	11	14	14
F	70	70	70	70	70	70
G	90	90	90	90	90	90
L	43	46	46	52	56	56
n-Øp	4-10	4-10	4-10	4-10	4-10	4-10
H	19	19	19	19	19	19
H1	31	31	31	36	36	36
L1	176	176	176	225	225	225
Torque	22	26	36	73	90	106
Kgs	4.5	6.5	7	10	16.5	17

N.	Part Name	Materials
1	Body	Ductile Iron GGG40
2	Disc	Stainless Steel 316
3	Seat	EPDM
4	Shaft	Stainless Steel 431
5	Bushing	Brass H65
6	Cotter Pin	Spring Steel 65Mn
7	Circlip	Spring Steel 65Mn
8	O-Ring	NBR
9	Ring	Nylon 6 PA6
10	Handle	AL102
11	Bolt	Stainless Steel 304

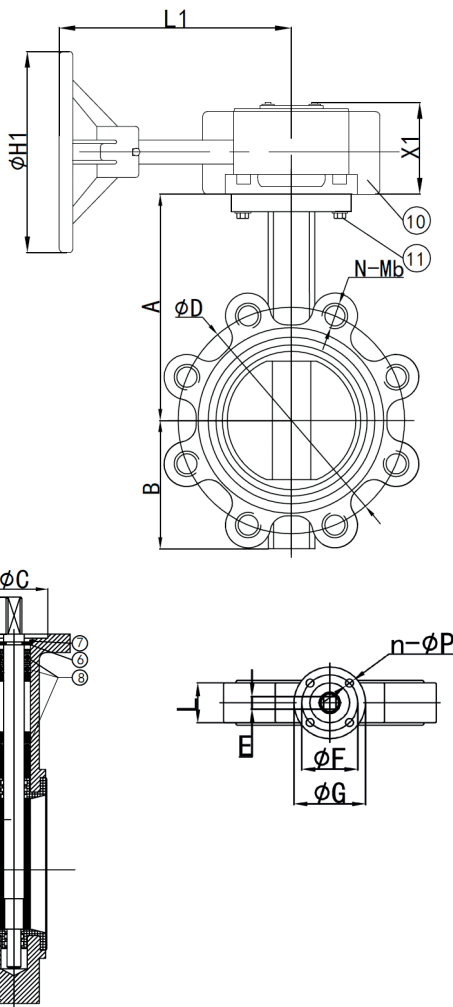

PN25 Ductile Iron Butterfly Valve Lugged & Tapped Type

Features

- Flange Mounting PN25 Only
- BS5155 (BS EN 593)
- ISO 5211 Direct Mount
- Epoxy Coat Finish
- Vulcanised Liner

Pressure/Temperature

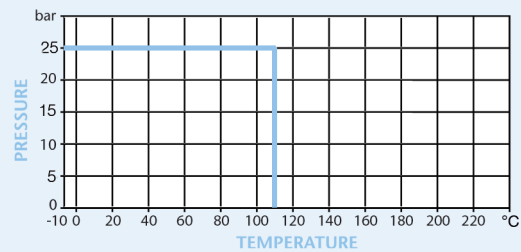

DN	200	250	300
A	247	280	324
B	173	207	250
C	71	71	71
D	310	370	430
N-Mb	12-M24	12-M27	16-M27
E	17	22	22
F	102	102	102
G	125	125	125
L	60	68	78
n-Øp	4-12	4-12	4-12
H	25	30	30
H1	215	215	215
L1	216	216	216
X1	71	71	71
Torque Kgs	290	400	510
	33	47	69

Technical Data

Max Pressure	25 Bar
Working Temperature	-10°C to +110°C

N.	Part Name	Materials
1	Body	Ductile Iron GGG40
2	Disc	Stainless Steel 316
3	Seat	EPDM
4	Shaft	Stainless Steel 431
5	Bushing	Brass H65
6	Cotter Pin	Spring Steel 65Mn
7	Circlip	Spring Steel 65Mn
8	O-Ring	NBR
9	Ring	Nylon 6 PA6
10	Gearbox	AL102
11	Bolt	Stainless Steel 304

Dimensions in mm

This data sheet is designed as a guide and should not be regarded as wholly accurate in every detail. We reserve the right to amend the specification of any product without notice.

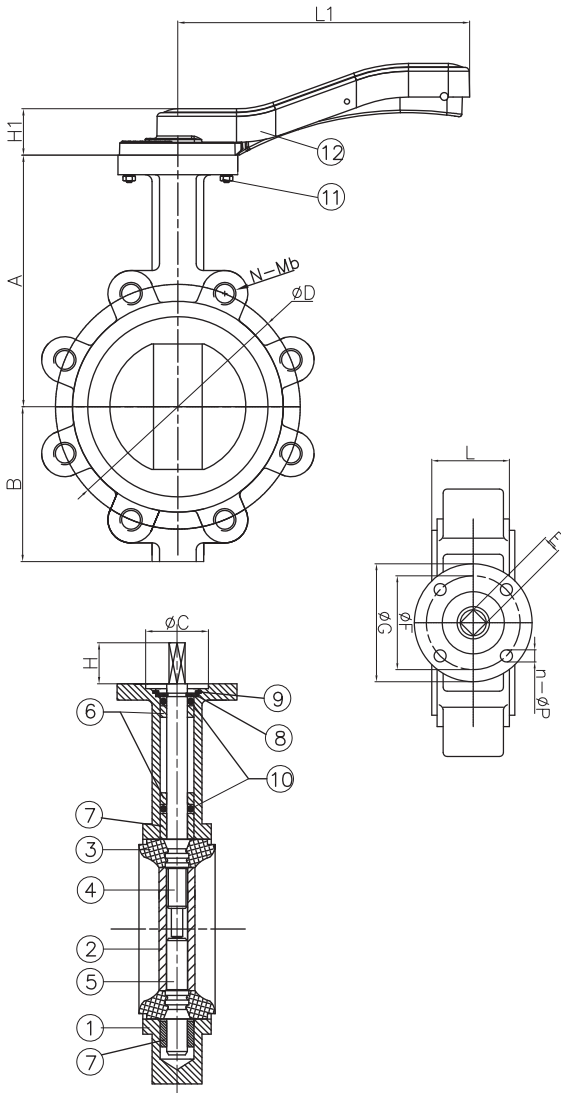

We strongly advise gearbox on all 8", 10" and 12" valves.

Technical Data

Maximum Pressure 16 Bar
Working Temperature 0°C to + 90°C

Dimensions in mm

This data sheet is designed as a guide and should not be regarded as wholly accurate in every detail. We reserve the right to amend the specification of any product without notice.

Ductile Iron Butterfly Valve Lugged & Tapped Type

Features

- Flange Mounting PN16 Only
- BS5155 (BS EN 593)
- ISO 5211 Direct Mount
- Lockable Handle
- Epoxy Coat Finish

Pressure/Temperature

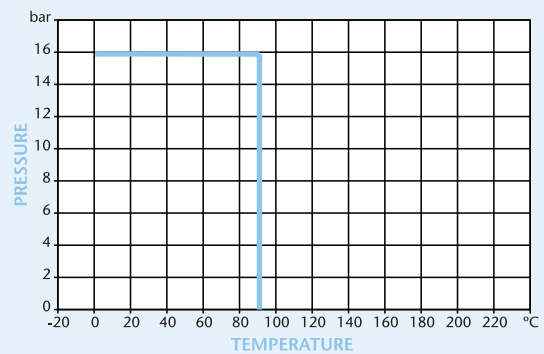

DN	50	65	80	100	125	150	200	250	300
A	142	154	161	179	193	204	250	282	326
B	75	80	91	110	125	137	178	208	241
C	56	56	56	56	56	56	71	71	71
D	125	145	160	180	210	240	295	355	410
E	11	11	11	11	14	14	17	22	22
F	70	70	70	70	70	70	102	102	102
G	90	90	90	90	90	90	125	125	125
H	19	19	19	19	19	19	25	30	30
H1	31	31	31	36	36	36	42	42	42
L	41.4	44	44.6	51.4	53.8	55.1	59.5	65	75.9
L1	176	176	176	225	225	225	300	359	359
N-Mb	4xM16	4xM16	8xM16	8xM16	8xM16	8xM20	12xM20	12xM24	12xM24
n-øp	4x10	4x10	4x10	4x10	4x10	4x10	4x12	4x12	4x12
Torque	19	21	28	43	60	91	194	295	412
Kgs	3.55	3.95	5.25	7	8.65	10.1	18.2	26.8	35.5

N.	Part Name	Materials
1	Body	Ductile Iron GGG40
2	Disc	Ductile Iron / Nickel Plated
3	Seat	NBR
4	Upper Shaft	Stainless Steel 410
5	Lower Shaft	Stainless Steel 411
6	Short Bush	PTFE
7	Long Bush	PTFE
8	Split Pin	Spring Steel
9	Circlip	Spring Steel
10	O-Ring	EPDM
11	Bolt	Carbon Steel
12	Lever	DN 50-150 Aluminium DN200-300 DI

Gearbox when fitted to ART110, 115, 120

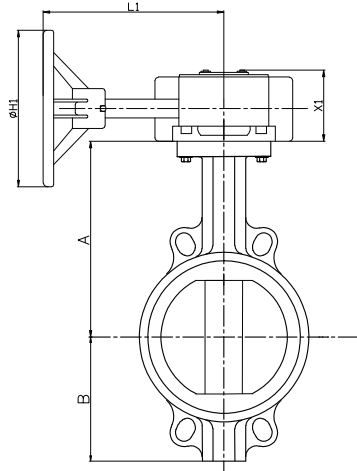

DN	50	65	80	100	125	150	200	250	300
A	142	154	161	179	193	204	250	282	326
B	60	78	87	105	120	138	174	209	242
H1	134	134	134	134	134	134	215	215	215
L1	145	145	145	145	145	145	216	216	216
X1	62	62	62	62	62	62	71	71	71

Gearbox when fitted to ART135, 145

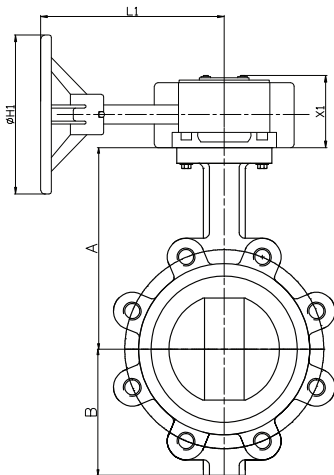

DN	50	65	80	100	125	150	200	250	300
A	142	154	161	179	193	204	250	282	326
B	75	80	91	110	125	137	178	208	241
H1	134	134	134	134	134	134	215	215	215
L1	145	145	145	145	145	145	216	216	216
X1	62	62	62	62	62	62	71	71	71

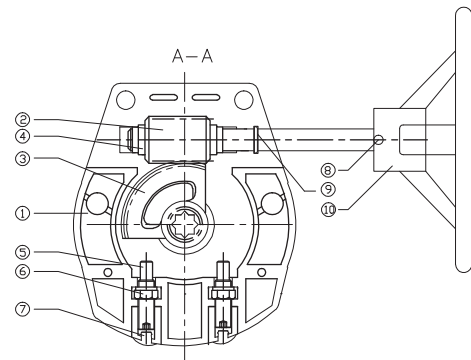
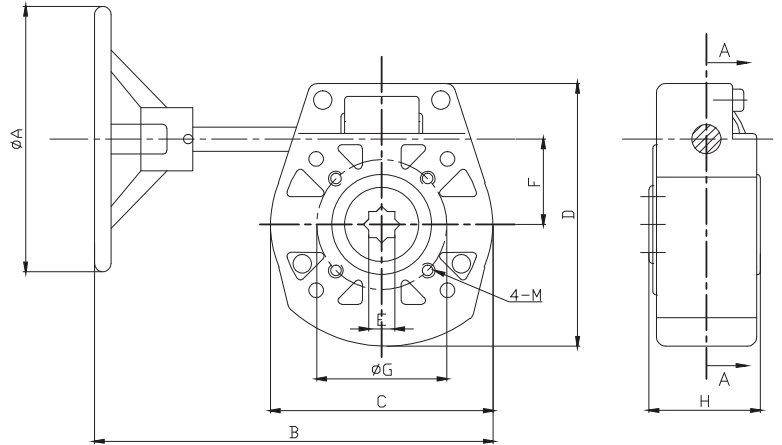

DN	2"-6"	8"-12"
A	134	215
B	205	302
C	120	172
D	132	189
E	14	22
F	46	70
G	70	102
H	62	72
4-M	4-M8	4-M10

N.	Part Name	Materials
1	Body	Aluminium
2	Worm Gear	Carbon Steel
3	Worm Wheel	Ductile Iron
4	Bushing	Brass
5	Limit Bolt	Carbon Steel
6	Stop Nut	Carbon Steel
7	Rubber Plug	Rubber
8	Pin	Carbon Steel
9	O-Ring	NBR
10	Hand Wheel	Aluminium

Dimensions in mm

This data sheet is designed as a guide and should not be regarded as wholly accurate in every detail. We reserve the right to amend the specification of any product without notice.

Cast Iron Dual Plate Wafer Check Valve

Features

- Universal Flange Mounting to suit BS EN 1092 PN10 / PN16 and ANSI B16.42 Class 150
- Conforms to BS EN 558-1 Series 16
- Epoxy Coat Finish

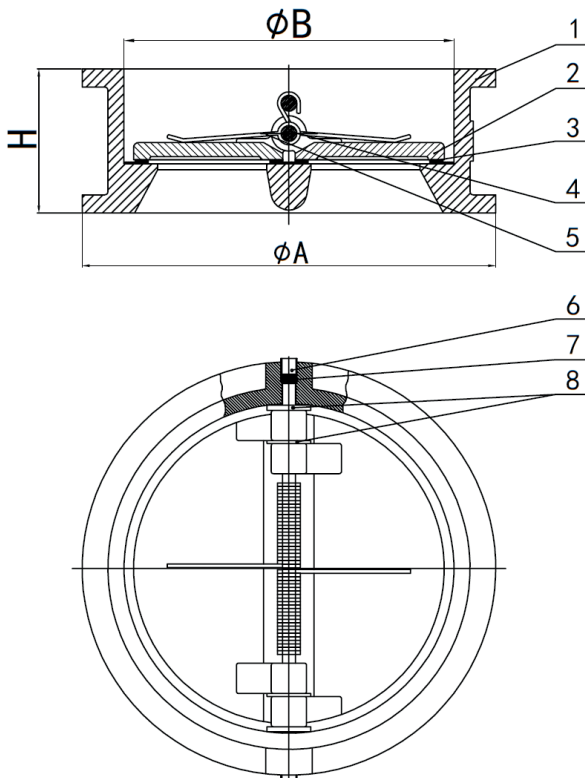
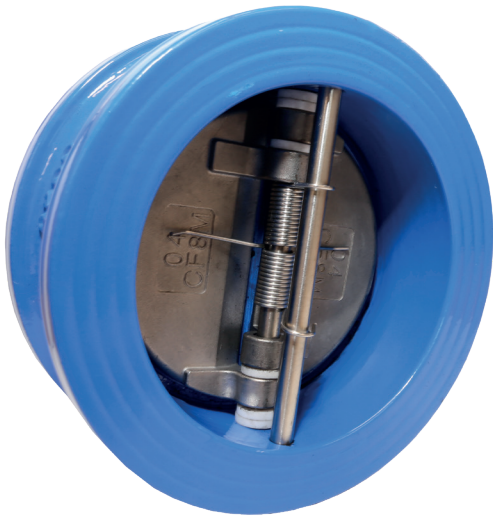

Technical Data

Maximum Pressure 16 Bar
Working Temperature -10°C to +120°C

Dimensions in mm

This data sheet is designed as a guide and should not be regarded as wholly accurate in every detail. We reserve the right to amend the specification of any product without notice.

Pressure/Temperature

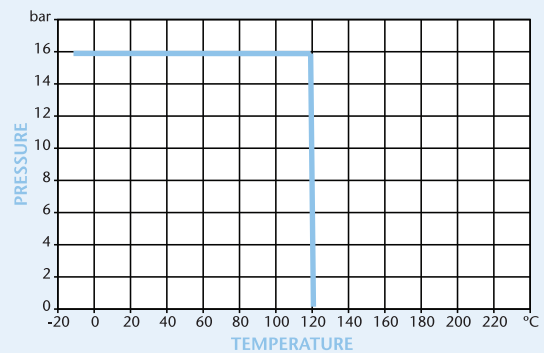

DN	50	65	80	100	125	150	200	250	300
A	107	127	142	162	192	218	273	328	378
B	65	80	94	117	145	170	224	265	310
H	43	46	64	64	70	76	89	114	114
Kgs	2	2.5	3.5	5	6	9	15	27	38

N.	Part Name	Materials
1	Body	Cast Iron GG25
2	Disc	Stainless Steel CF8M
3	Seat	EPDM
4	Shaft	Stainless Steel 420
5	Spring	Stainless Steel 316
6	Plug	Steel
7	Plug	NBR
8	Washer	PTFE

Cast Iron Dual Plate Wafer Check Valve

Features

- Flange Mounting to suit BS EN 1092 PN16 only
- Conforms to BS EN 558-1 Series 16
- Epoxy Coat Finish

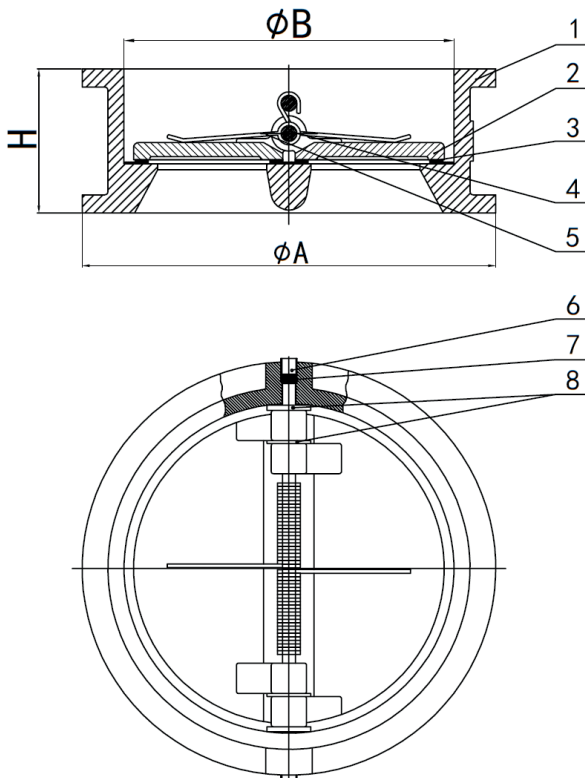
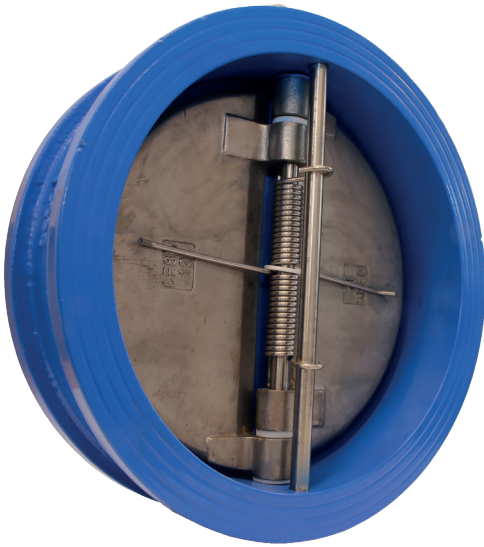

Technical Data

Maximum Pressure 16 Bar
Working Temperature -10°C to +120°C

Dimensions in mm

This data sheet is designed as a guide and should not be regarded as wholly accurate in every detail. We reserve the right to amend the specification of any product without notice.

Pressure/Temperature

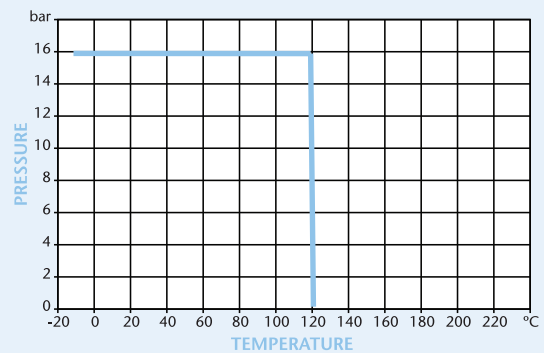

DN	350	400	450	500	600
A	442	495	555	617	734
B	360	410	450	505	624
H	127	140	152	152	178
Kgs	69	80	103	118	192

N.	Part Name	Materials
1	Body	Cast Iron GG25
2	Disc	Stainless Steel CF8M
3	Seat	EPDM
4	Shaft	Stainless Steel 420
5	Spring	Stainless Steel 316
6	Plug	Steel
7	Plug	NBR
8	Washer	PTFE

Cast Iron Dual Plate Wafer Check Valve

Features

- Flange Mounting to suit ANSI B16.42 Class 150 only
- Conforms to API 594
- Epoxy Coat Finish

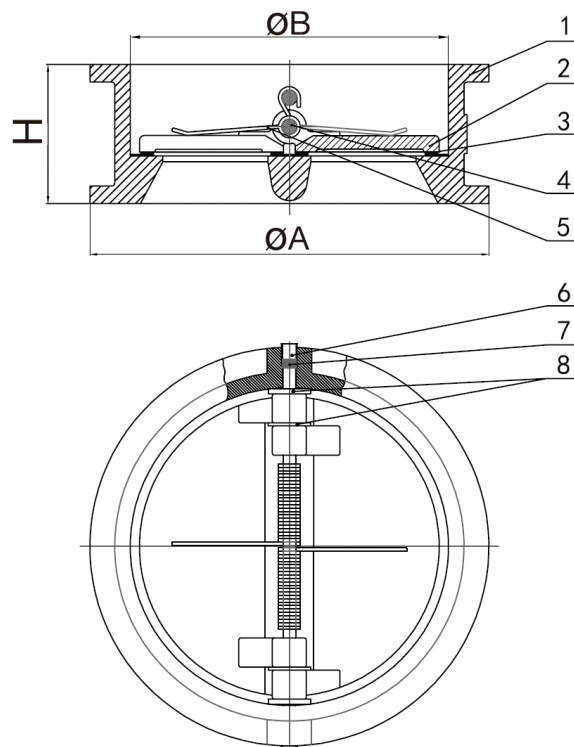
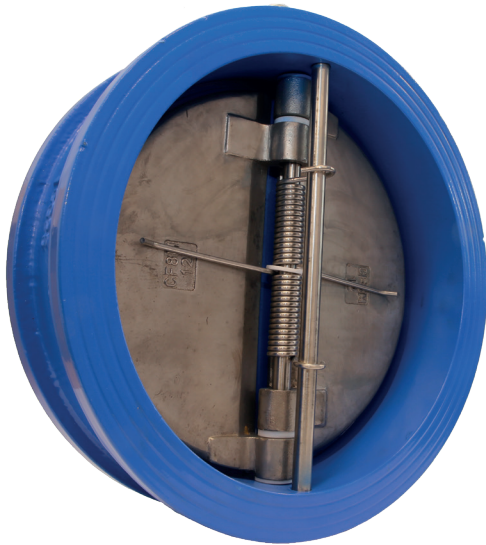

Technical Data

Maximum Pressure 16 Bar
Working Temperature -10°C to +120°C

Dimensions in mm

This data sheet is designed as a guide and should not be regarded as wholly accurate in every detail. We reserve the right to amend the specification of any product without notice.

Pressure/Temperature

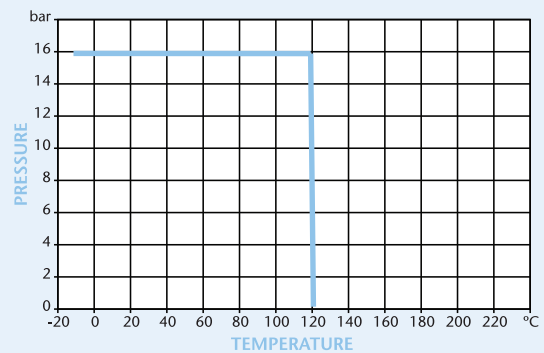

DN	350	400	450	500	600
A	447	511	546	603	714
B	375	416	467	514	616
H	184	191	203	219	222
Kgs	69	80	103	118	192

N.	Part Name	Materials
1	Body	Cast Iron GG25
2	Disc	Stainless Steel CF8M
3	Seat	EPDM
4	Shaft	Stainless Steel 410
5	Spring	Stainless Steel 316
6	Plug	Steel
7	Plug	NBR
8	Washer	PTFE

PN16 Ductile Iron Silent Check Valve

Features

- Flange conforms to BS EN1092 PN16
- Valve design conforms to BS EN12334
- Valve inspection and testing in accordance with BS EN12266



Pressure/Temperature

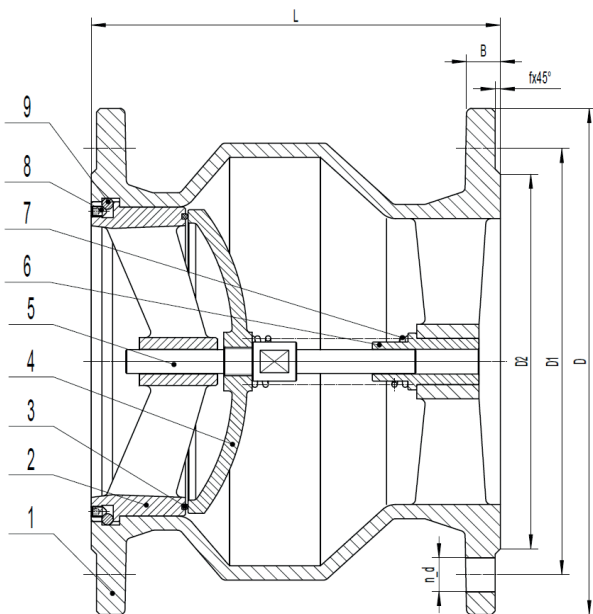
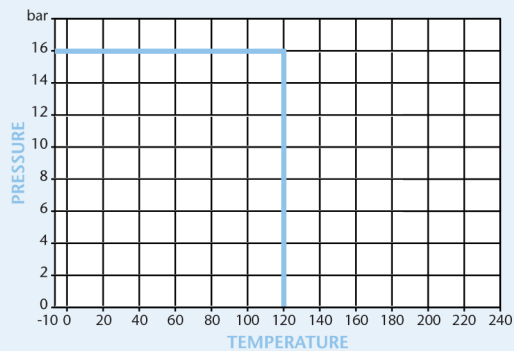

	2"	2½"	3"	4"	5"	6"	8"	10"	12"	14"	16"
L	133	140	152	185	216	230	259	362	393	400	448
D	165	185	200	220	250	285	340	405	460	520	580
D1	125	145	160	180	210	240	295	355	410	470	525
D2	99	118	132	156	184	211	266	319	370	429	480
B	19	19	19	19	19	19	20	22	24.5	26.5	28
f	3	3	3	3	3	3	3	3	4	4	4
n-d	4-19	4-19	8-19	8-19	8-19	8-23	12-12	12-28	12-28	16-28	16-31
Kgs	7.6	9.4	10.2	13.6	18.7	25.1	39.6	70.1	95.2	143.4	196

Technical Data

Max Pressure	16 Bar
Working Temperature	-10°C to +120°C

Dimensions in mm

This data sheet is designed as a guide and should not be regarded as wholly accurate in every detail. We reserve the right to amend the specification of any product without notice.

N.	Part Name	Materials
1	Body	Ductile Iron - BS EN1563 EN-GJS-450-10
2	Seat Body	Ductile Iron - BS EN1563 EN-GJS-450-10
3	Seat	EPDM
4	Disc	Ductile Iron - BS EN1563 EN-GJS-450-10
5	Stem	Stainless Steel - BS970 304S15
6	Bushing	Brass - BS2874 CZ122
7	Spring	Stainless Steel - BS970 304S15
8	Screw	Stainless Steel - BS970 304S15
9	Ball	Stainless Steel - BS970 304S15

PN25 Cast Iron Swing Check Valve

Features

- Flange Mounting PN25 Only
- Flange conforms to BS EN1092 PN25
- BS5153 (BS EN 558-1 Series 21)



Pressure/Temperature

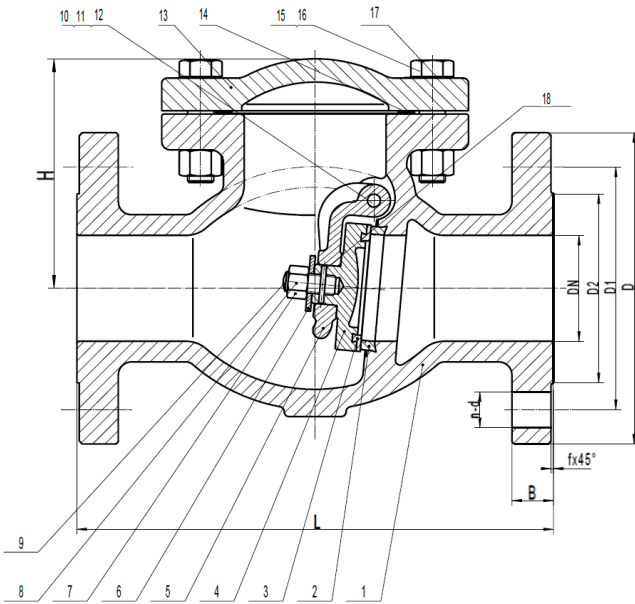
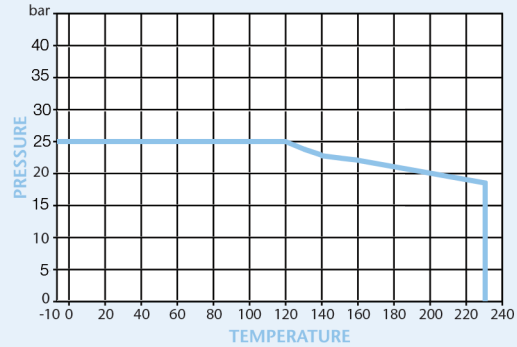

	2"	2½"	3"	4"	5"	6"	8"	10"	12"
L	267	292	318	356	400	444	533	622	711
D	165	191	210	254	279	318	381	445	521
D1	125	145	160	190	220	250	310	370	430
D2	99	118	132	156	184	211	274	330	389
B	22.2	25.4	28.6	31.8	34.9	36.5	41.3	47.6	50.8
n-d	4-19	8-19	8-19	8-23	8-28	8-28	12-28	12-31	16-31
f	3	3	3	3	3	3	3	3	4
H	135	150	166	190	206	244	291	337	383
Kgs	17.6	31	35.8	55.7	80.4	110.9	180	277	408.5

N.	Part Name	Materials
1	Body	Cast Iron - BS EN1561 EN-GJL-250
2	Seat Ring	Cast Bronze - BS1400 LG2
3	Disc Ring	Cast Bronze - BS1400 LG2
4	Disc	Cast Iron - BS EN1561 EN-GJL-250
5	Hanger	Ductile Iron - BS EN1563 EN-GJS-450-10
6	Washer	Stainless Steel - BS970 304S15
7	Nut	Stainless Steel - BS970 304S15
8	Split Pin	Stainless Steel - BS970 304S15
9	Disc Screw	Stainless Steel - BS970 304S15
10	Side Pin	Brass - BS2874 CZ122
11	Gasket	Teflon
12	Hanger Pin	Stainless Steel - BS970 304S15
13	Bonnet	Cast Iron - BS EN1561 EN-GJL-250
14	Gasket	EPDM - BS EN681-1 IRHD66-75
15	Bolt	Stainless Steel - BS970 304S15
16	Nut	Stainless Steel - BS970 304S15
17	Identification Plate	Aluminium
18	Pin	Stainless Steel - BS970 304S15

Technical Data

Maximum Pressure	25 Bar
Working Temperature	-10°C to +230°C

Dimensions in mm

This data sheet is designed as a guide and should not be regarded as wholly accurate in every detail. We reserve the right to amend the specification of any product without notice.

ANSI Cast Iron Swing Check Valve

Features

- Flanged ANSI 125 (B16.1)
- Class 125 Rated
- Conforms to ASME B16.10
- Conforms to MSS SP-71



Pressure/Temperature

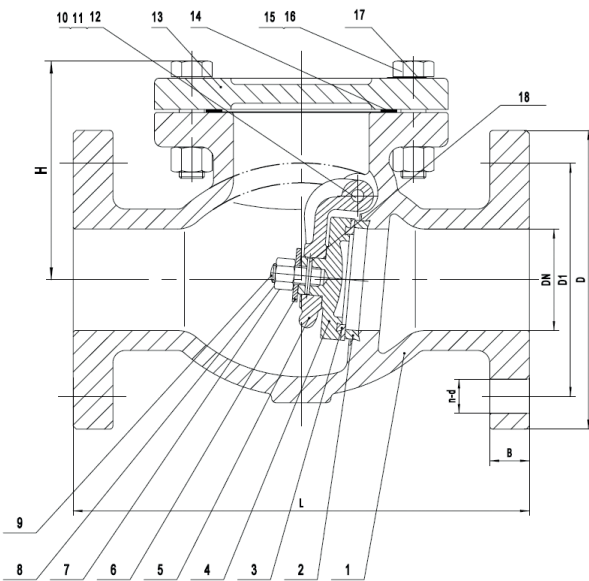
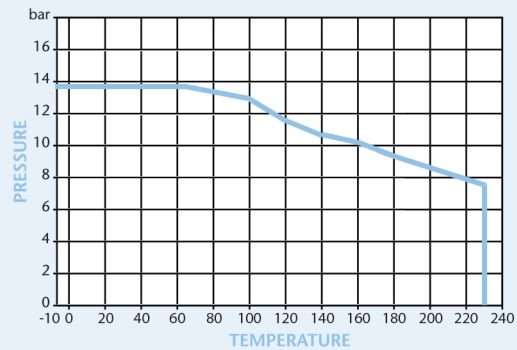

	2"	2½"	3"	4"	5"	6"	8"	10"	12"	14"	16"	18"	20"	24"
L	203	216	241	292	330	356	495	622	699	787	914	914	1016	1219
D	152	178	190	229	254	279	343	406	483	533	597	635	699	813
D1	121	140	153	191	216	241	299	362	432	476	540	578	635	750
B	16	18	19	24	24	25	29	30	32	35	37	40	43	48
n-d	4-	4-	4-	8-	8-	8-	8-	12-	12-	12-	16-	16-	20-	20-
	19	19	19	19	22.2	22.2	22.2	25.4	25.4	28.6	28.6	32	32	35
H	112	132	141	162	192	211	270	316	357	560	589	645	702	812
Kgs	11.6	17.5	21.4	37	56.2	72.4	122.7	201	291	418.5	520	656	832	1260

N.	Part Name	Materials
1	Body	Cast Iron - ASTM A 126-B
2	Seat Ring	Cast Bronze - ASTM B 62
3	Disc Ring	Cast Bronze - ASTM B 62
4	Disc	Cast Iron - ASTM A 126-B
5	Hanger	Ductile Iron - ASTM A 536 65-45-12
6	Washer	Steel
7	Nut	Steel
8	Split Pin	Stainless Steel - ASTM 304
9	Disc Screw	Steel
10	Side Pin	Brass - ASTM B 16
11	Gasket	Teflon
12	Hanger Pin	Stainless Steel - ASTM 304
13	Bonnet	Cast Iron - ASTM A 126-B
14	Gasket	Graphite - Non-Asbestos
15	Bolt	Steel - ASTM A 307-B
16	Nut	Steel - ASTM A 563-B
17	Identification Plate	Aluminium
18	Pin	Stainless Steel - ASTM 304

Technical Data

Maximum Pressure	13.8 Bar
Working Temperature	-10°C to +230°C

Dimensions in mm

This data sheet is designed as a guide and should not be regarded as wholly accurate in every detail. We reserve the right to amend the specification of any product without notice.

PN16 Cast Iron Swing Check Valve

Features

- Flange Mounting PN16 Only
- Flange conforms to BS EN1092 PN16
- BS5153 (BS EN 558-1 Series 10)



Pressure/Temperature

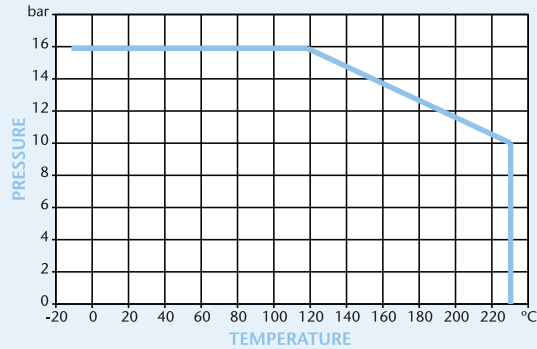

DN	50	65	80	100	125	150	200	250	300	350	400	450	500	600
L	203	216	241	292	330	356	495	622	699	787	914	914	1016	1219
D	165	185	200	220	250	285	340	405	460	520	580	640	715	840
D1	125	145	160	180	210	240	295	355	410	470	525	585	650	770
D2	99	118	132	156	184	211	266	319	370	429	480	548	609	720
B	20	20	22	24	26	26	30	32	32	36	38	40	42	48
f	3	3	3	3	3	3	3	3	4	4	4	4	4	5
n-d	4-19	4-19	8-19	8-19	8-19	8-23	12-23	12-28	12-28	16-28	16-31	20-31	20-34	20-37
H	112	132	141	162	192	211	270	316	357	560	589	645	702	812
kgs	11.6	17.5	21.4	37	56.2	72.4	123	201	291	419	520	656	832	1260

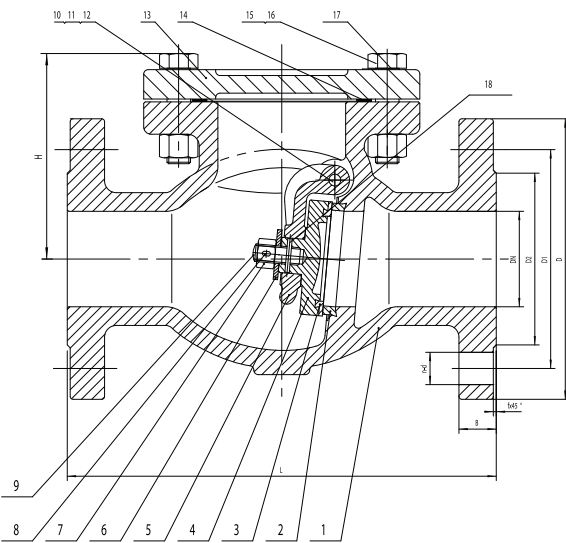

Technical Data

Maximum Pressure 16 Bar
 Working Temperature -10°C to +230°C

Dimensions in mm

This data sheet is designed as a guide and should not be regarded as wholly accurate in every detail. We reserve the right to amend the specification of any product without notice.

N.	Part Name	Materials
1	Body	Cast Iron - BS EN1561 EN-GJL-250
2	Seat Ring	Cast Bronze - BS1400 LG2
3	Disc Ring	Cast Bronze - BS1400 LG2
4	Disc Ring	Cast Iron - BS EN1561 EN-GJL-250
5	Hanger	Ductile Cast Iron - BS EN1563 EN-GJS-450-10
6	Washer	Steel - BS970 43A
7	Nut	Steel - BS970 43A
8	Split Pin	Stainless Steel - BS970 304S15
9	Disc Screw	Steel - BS970 43A
10	Side Pin	Brass - BS2874 CZ122
11	Gasket	Soft Steel Cardboard
12	Hanger Pin	Stainless Steel - BS970 304S15
13	Bonnet	Cast Iron - BS EN1561 EN-GJL-250
14	Gasket	Graphite
15	Bolt	Steel - BS970 43A
16	Nut	Steel - BS970 43A
17	Identification Plate	Aluminium
18	Pin	Stainless Steel - BS970 304S15

PN25 Cast Iron Swing Check Valve, Lever & Weight

Features

- Flange Mounting to PN25 Only
- Flange conforms to BS EN1092 PN25
- Conforms to BS5153 (BS EN558-1)

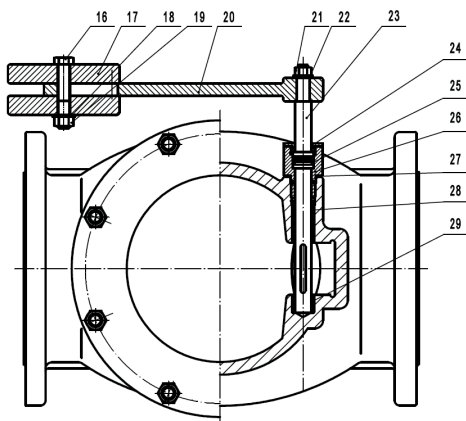
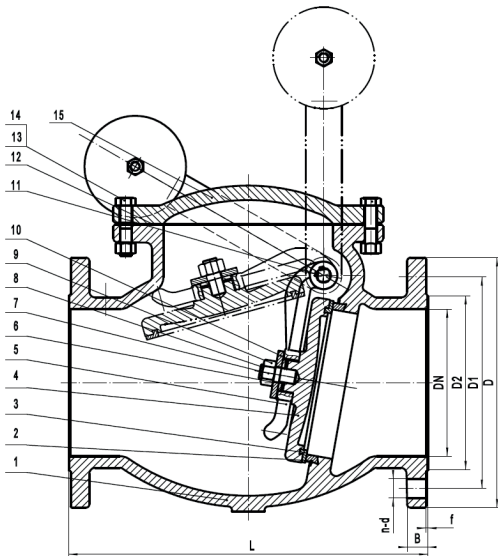

Pressure/Temperature

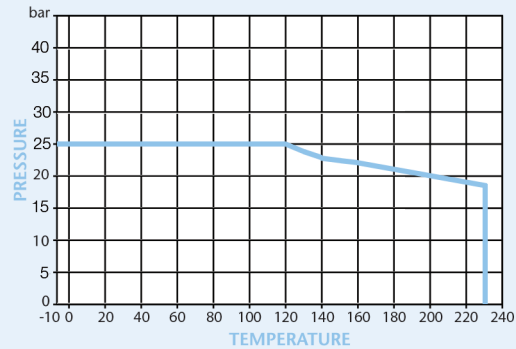

	50	65	80	100	125	150	200	250	300
L	267	292	318	356	400	444	533	622	711
D	165	185	200	235	270	300	360	425	485
D1	125	145	160	190	220	250	310	370	430
D2	99	118	132	156	185	211	274	330	389
B	22	25	29	32	35	37	41	48	51
f	3	3	3	3	3	3	3	3	4
n-d	4-19	8-19	8-19	8-23	8-28	8-28	12-28	12-31	16-31

N.	Part Name	Materials
1	Body	Cast Iron - BS1452 Gr.220
2	Seat Ring	Cast Bronze - BS1400 LG2
3	Disc Ring	Cast Bronze - BS1400 LG2
4	Disc	Cast Iron - BS1452 Gr.220
5	Hanger	Ductile Iron - BS2789 Gr500-7
6	Pin	Stainless Steel - BS970 304S15
7	Split Pin	Stainless Steel - BS970 304S15
8	Disc Screw	Steel - BS970 43A
9	Nut	Steel - BS970 43A
10	Washer	Steel - BS970 43A
11	Bond	Steel - BS970 43A
12	Gasket	Soft Steel Cardboard
13	Bolt	Steel - BS970 43A
14	Nut	Steel - BS970 43A
15	Bonnet	Cast Iron - BS1452 Gr.220
16	Bolt	Steel - BS970 43A
17	Balance Weight	Cast Iron - BS1452 Gr.220
18	Washer	Steel - BS970 43A
19	Nut	Steel - BS970 43A
20	Connecting Lever	Ductile Iron - BS2789 Gr.500-7
21	Nut	Steel - BS970 43A
22	Washer	Steel - BS970 43A
23	Hanger Axle	Stainless Steel - BS970 304S15
24	Gland Nut	Brass - BS2874 CZ122
25	Gland	Brass - BS2874 CZ122
26	O-Ring	EPDM
27	Washer	Teflon
28	Outside Bush	Brass - BS2874 CZ122
29	Inside Bush	Brass - BS2874 CZ122

Technical Data

Max Pressure	25 Bar
Working Temperature	-10°C to +230°C

Dimensions in mm

This data sheet is designed as a guide and should not be regarded as wholly accurate in every detail. We reserve the right to amend the specification of any product without notice.

ANSI Cast Iron Swing Check Valve, Lever & Weight

Features

- Flanged ANSI 125 (B16.1)
- Class 125 Rated
- Conforms to ASME B16.10
- Conforms to MSS SP-71

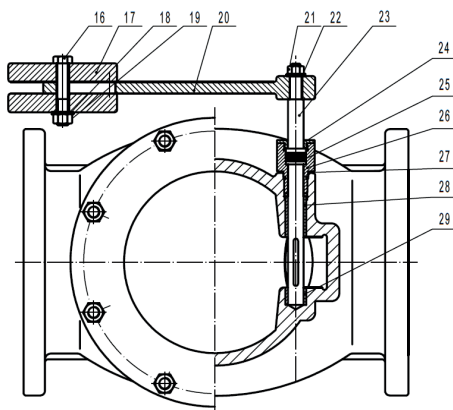
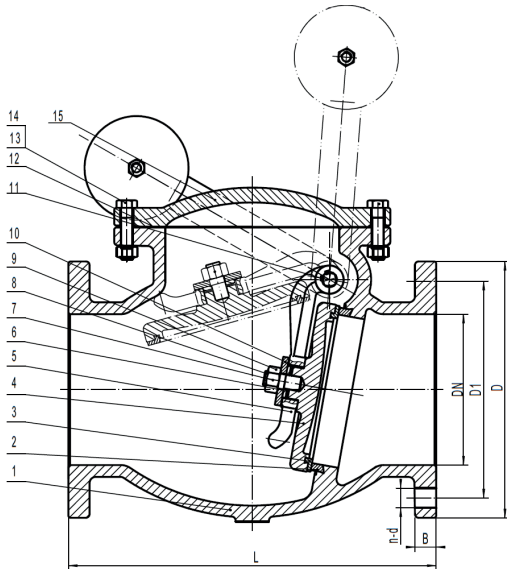
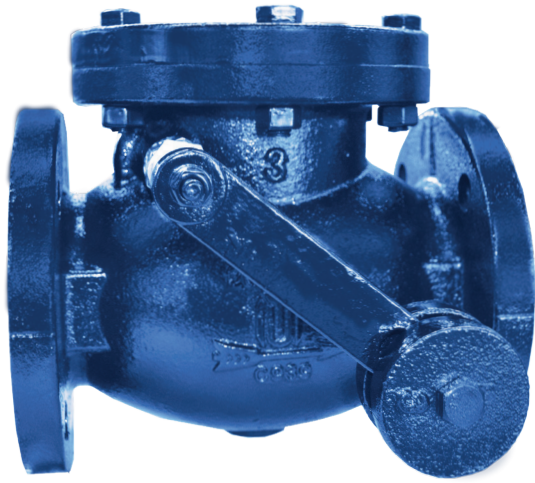

Pressure/Temperature

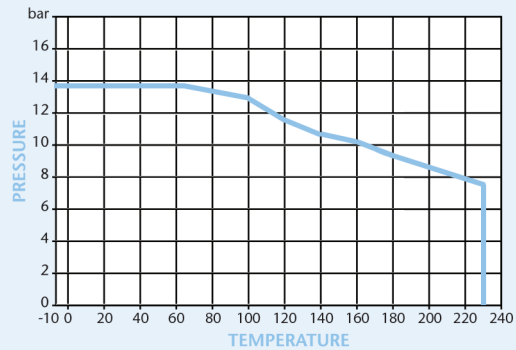

	2"	2½"	3"	4"	5"	6"	8"	10"	12"	14"	16"	18"	20"	24"
L	203	216	241	292	330	356	495	622	699	787	914	914	1016	1219
D	152	178	190	229	254	279	343	406	483	533	597	635	699	813
D1	121	140	153	191	216	241	299	362	432	476	540	578	635	750
B	16	18	19	24	24	25	29	30	32	35	37	40	43	48
n-d	4-	4-	4-	8-	8-	8-	8-	12-	12-	12-	16-	16-	20-	20-35
Kgs	13.8	19.5	23.6	38	59	79.6	126.9	243	291	456	586	710	900	1350

N.	Part Name	Materials
1	Body	Cast Iron - ASTM A 126-B
2	Seat Ring	Cast Bronze - ASTM B 62
3	Disc Ring	Cast Bronze - ASTM B 62
4	Disc	Cast Iron - ASTM A 126 B
5	Hanger	Ductile Iron - ASTM A536
6	Pin	Stainless Steel - ASTM 304
7	Split Pin	Stainless Steel - ASTM 304
8	Disc Screw	Steel
9	Nut	Steel
10	Washer	Steel
11	Bond	Steel
12	Gasket	Teflon
13	Bolt	Steel
14	Nut	Steel
15	Bonnet	Cast Iron - ASTM A 126-B
16	Bolt	Steel
17	Balance Weight	Cast Iron - ASTM A 126-B
18	Washer	Steel
19	Nut	Steel
20	Connecting Lever	Ductile Iron - ASTM A536
21	Nut	Steel
22	Washer	Steel
23	Hanger Axle	Stainless Steel - ASTM 304
24	Gland	Brass - ASTM B 16
25	O-Ring	EPDM
26	Stuffing Box	Brass - ASTM B 16
27	Washer	Teflon
28	Outside Bush	Brass - ASTM B 16
29	Inside Bush	Brass - ASTM B 16

Technical Data

Max Pressure	13.8 Bar
Working Temperature	-10°C to +230°C

Dimensions in mm

This data sheet is designed as a guide and should not be regarded as wholly accurate in every detail. We reserve the right to amend the specification of any product without notice.

PN16 Cast Iron Swing Check Valve, Lever & Weight

Features

- Flange Mounting PN16 Only
- Flange conforms to BS EN1092 PN16
- Conforms to BS EN12334
- Sizes DN50-400 conform to BS 5153 (BS EN558-1 Series 10)



Pressure/Temperature

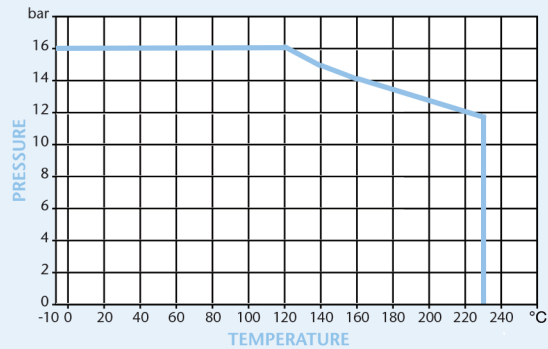

	50	65	80	100	125	150	200	250	300	350	400	450	500	600
L	203	216	241	292	330	356	495	622	699	787	914	914	1016	1219
D	165	185	200	220	250	285	340	405	460	520	580	640	715	840
D1	125	145	160	180	210	240	295	355	410	470	525	585	650	770
D2	99	118	132	156	184	211	266	319	3780	429	480	548	609	720
B	20	20	22	24	26	26	30	32	32	36	38	40	42	48
n-d	4-19	4-19	8-19	8-19	8-19	8-23	12-23	12-28	12-28	16-28	16-31	20-31	20-34	20-37
f	3	3	3	3	3	3	3	3	4	4	4	4	4	5
Kgs	13.8	19.5	23.6	38	59	79.6	126.9	243	291	456	586	710	900	1350

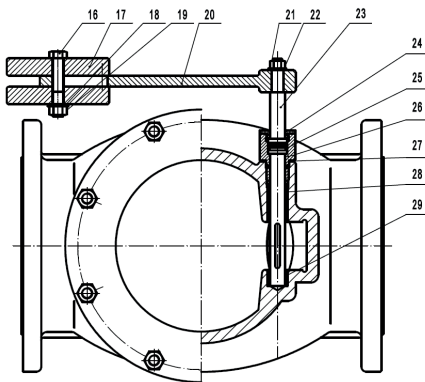
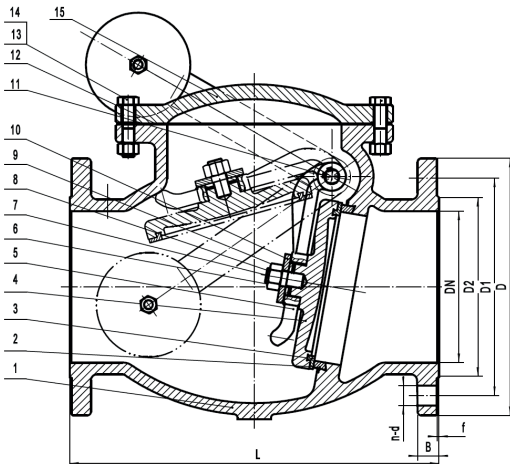

Technical Data

Max Pressure 16 Bar
Working Temperature -10°C to +230°C

N.	Part Name	Materials
1	Body	Cast Iron - BS EN1561 EN-GJL-250
2	Seat Ring	Cast Bronze - BS1400 LG2
3	Disc Ring	Cast Bronze - BS1400 LG2
4	Disc	Cast Iron - BS EN1561 EN-GJL-250
5	Hanger	Ductile Iron - BS EN1563 EN-GJS-450-10
6	Pin	Stainless Steel - BS970 304S15
7	Split Pin	Stainless Steel - BS970 304S15
8	Disc Screw	Steel - BS970 43A
9	Nut	Steel - BS970 43A
10	Washer	Steel - BS970 43A
11	Bond	Steel - BS970 43A
12	Gasket	Soft Steel Cardboard
13	Bolt	Steel - BS970 43A
14	Nut	Steel - BS970 43A
15	Bonnet	Cast Iron - BS EN1561 EN-GJL-250
16	Bolt	Steel - BS970 43A
17	Balance Weight	Cast Iron - BS EN1561 EN-GJL-250
18	Washer	Steel - BS970 43A
19	Nut	Steel - BS970 43A
20	Connecting Lever	Ductile Iron - BS EN1563 EN-GJS-450-10
21	Nut	Steel - BS970 43A
22	Washer	Steel - BS970 43A
23	Hanger Axle	Stainless Steel - BS970 304S15
24	Gland Nut	Brass - BS2874 CZ122
25	Gland	Brass - BS2874 CZ122
26	O-Ring	EPDM
27	Washer	Teflon
28	Outside Bush	Brass - BS2874 CZ122
29	Inside Bush	Brass - BS2874 CZ122

Dimensions in mm

This data sheet is designed as a guide and should not be regarded as wholly accurate in every detail. We reserve the right to amend the specification of any product without notice.

PN16 Ductile Iron Ball Check Valve

Features

- Screwed BSP Parallel (ISO 228/1)
- Epoxy Coat Finish

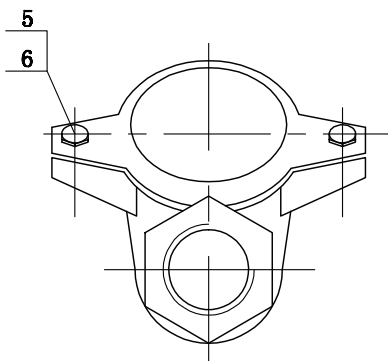
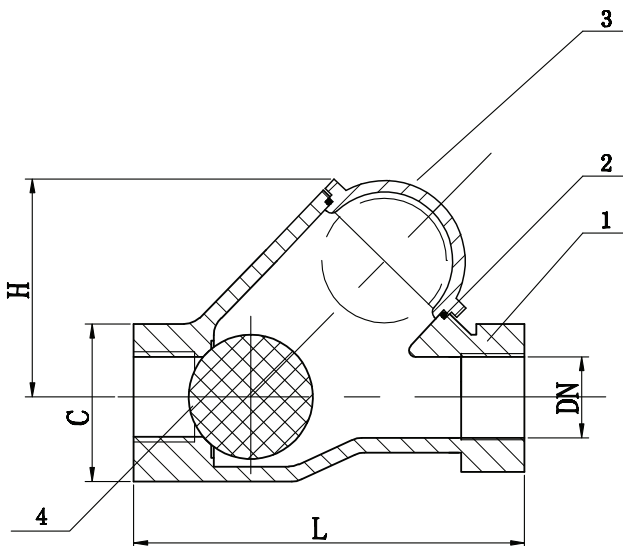

Pressure/Temperature

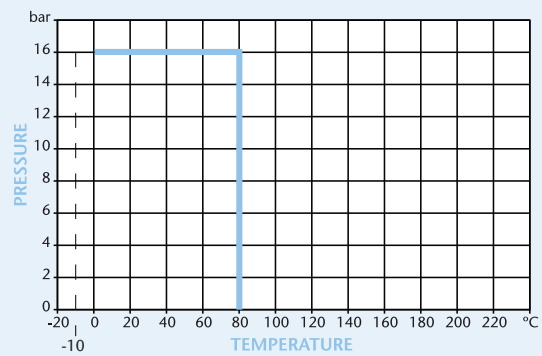

DN	L	C	H	Kgs
25	125	47	75	1.33
32	132	59	75	1.71
40	145	70	85	1.71
50	174	82	126	4.16
65	200	106	113	5.46
80	243	132	165	10.00

N	Part Name	Material
1	Body	Ductile Iron
2	Gasket	NBR
3	Cap	Ductile Iron
4	Ball	NBR
5	Bolt	Steel
6	Nut	Steel

Technical Data

Maximum Pressure 16 Bar
 Working Temperature: 0°C to +80°C

Dimensions in mm

This data sheet is designed as a guide and should not be regarded as wholly accurate in every detail. We reserve the right to amend the specification of any product without notice.

PN16 Ductile Iron Ball Check Valve

Features

- Flanged Mounting PN16 Only
- Valve Design According to EN12334
- DIN3202 Face-to-Face
- Epoxy Coat Finish

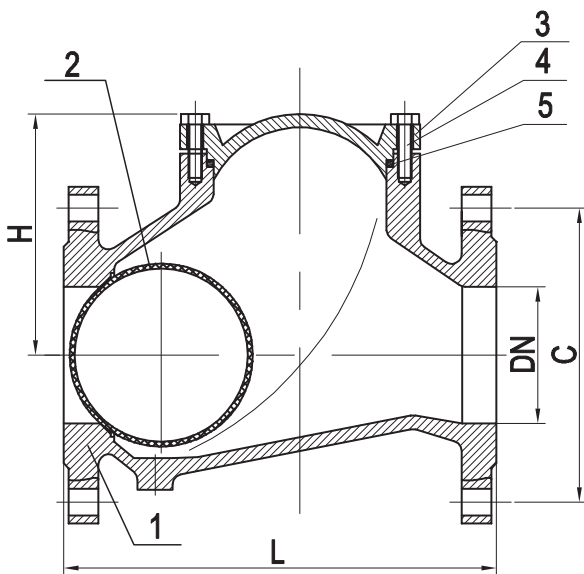

Pressure/Temperature

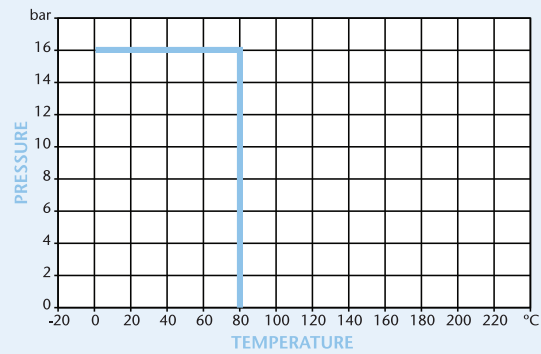

DN	L	C	H	Kgs
50	200	106	125	7.7
65	240	129	145	11.2
80	260	146	160	15.4
100	300	194	180	21.7
125	350	207	210	33.0
150	400	240	240	45.3
200	500	322	295	90.42
250	600	388	355	163.0
300	700	458	410	230.0

Technical Data

Maximum Pressure 16 Bar
 Working Temperature: 0°C to +80°C

Dimensions in mm

This data sheet is designed as a guide and should not be regarded as wholly accurate in every detail. We reserve the right to amend the specification of any product without notice.

N	Part Name	Material
1	Body	Ductile Iron
2	Ball	Metal NBR Coated
3	Cap	Ductile Iron
4	Bolt	Steel
5	Gasket	NBR

PN16 Cast Iron "Y" Strainer

Features

- Flange Mounting PN16 Only
- BS EN 558-1 Series 1
- DN50 & DN65 Square Drain Port
- DN80 - DN600 Circular Drain Port

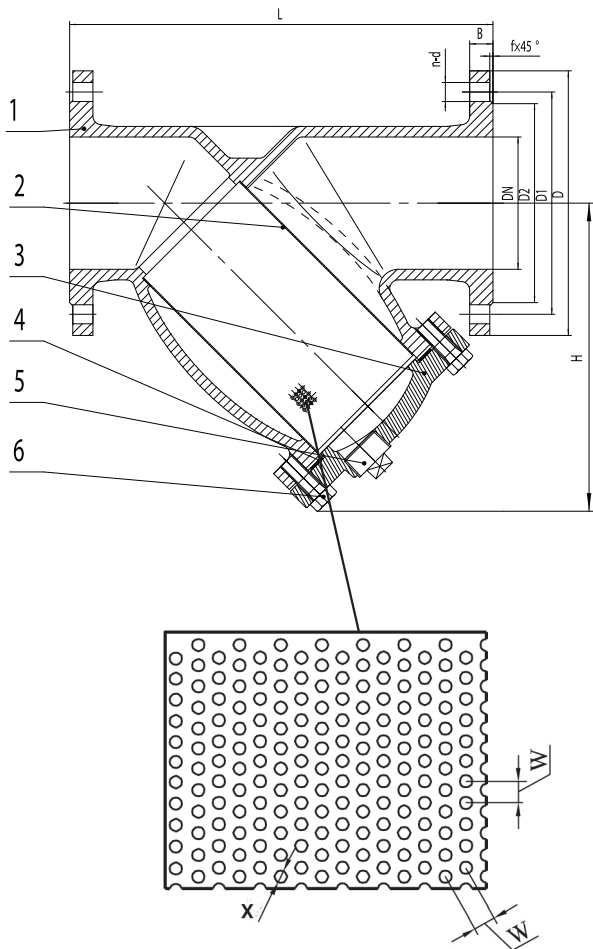

Technical Data

Maximum Pressure	16 Bar
Working Temperature	-10°C to +230°C

Dimensions in mm

This data sheet is designed as a guide and should not be regarded as wholly accurate in every detail. We reserve the right to amend the specification of any product without notice.

Pressure/Temperature

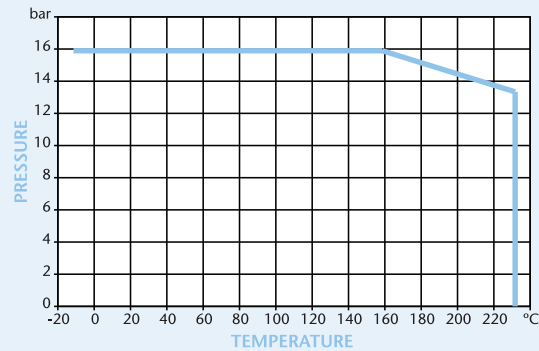

DN	50	65	80	100	125	150	200	250	300	350	400	450	500	600
L	230	290	310	350	400	480	600	730	850	980	1100	1200	1250	1450
D	165	185	200	220	250	285	340	405	460	520	580	640	715	840
D1	125	145	160	180	210	240	295	355	410	470	525	585	650	770
D2	99	118	132	156	184	211	266	319	370	438	490	548	609	720
B	20	20	22	24	26	26	30	32	32	36	38	40	42	48
f	3	3	3	3	3	3	3	3	4	4	4	4	4	5
n-d	4-19	4-19	8-19	8-19	8-19	8-23	12-23	12-28	12-28	16-28	16-31	20-31	20-34	20-37
H	156	176	199	240	292	320	399	516	568	648	759	777	825	944
X	1.5	1.5	1.5	1.5	1.5	1.5	1.5	1.5	1.5	1.5	1.5	1.5	1.5	1.5
W	2.5	2.5	2.5	2.5	2.5	2.5	2.5	2.5	2.5	2.5	2.5	2.5	2.5	2.5
kgs	10.1	14	20.3	26.6	39.8	57	97	164	234	312	444	560	652	1072

N.	Part Name	Materials
1	Body	Cast Iron - BS EN1561 EN-GJL250
2	Screen	Stainless Steel - BS970 304S15
3	Bonnet	Cast Iron - BS EN1561 EN-GJL250
4	Gasket	Graphite
5	Screw Plug	Cast Brass - BS2874 CZ122
6	Bolt	Steel - BS970 43A

ANSI 150 Cast Iron "Y" Strainer

Features

- Flanged ANSI 150 (B16.5)
- Class 150 Rated
- Conforms to ASME B16.10

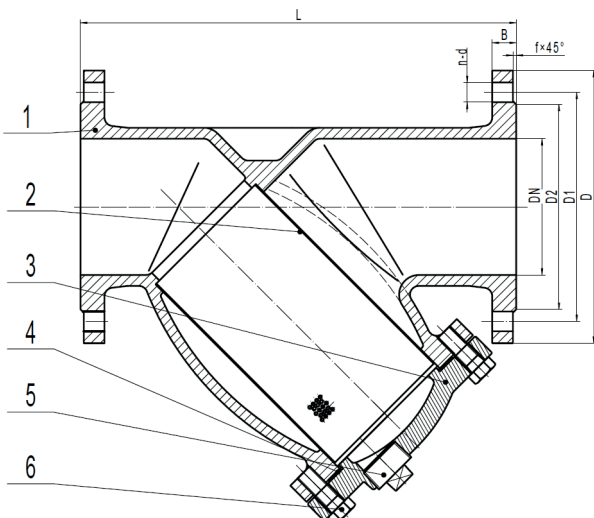

Pressure/Temperature

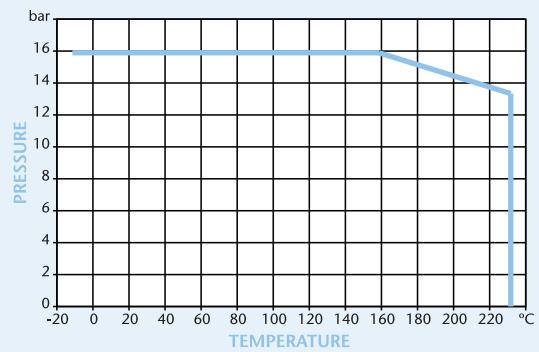

	2"	2½"	3"	4"	5"	6"	8"	10"	12"	14"	16"	18"	20"	24"
L	230	290	310	350	400	480	600	730	850	980	1100	1200	1250	1450
D	165	185	200	228.6	250	285	340	405	483	533.4	597	640	715	840
D1	121	140	152.5	190.5	215.9	241.3	298.5	362	432	476.3	539.8	578	635	749.5
D2	92	105	127	156	184	211	266	319	370	413	470	533	584	692
B	20	20	22	24	26	26	30	32	32	36	38	40	42	48
f	1.6	1.6	1.6	1.6	1.6	1.6	1.6	1.6	1.6	1.6	1.6	1.6	1.6	1.6
n-d	4-19	4-19	4-19	8-19	8-22.2	8-22.2	8-22.2	12-25.4	12-25.4	12-28.6	16-28.6	16-32	20-32	20-35
Kgs	10.1	14	20.3	26.6	39.8	57	97	164	234	312	444	560	652	1072

Technical Data

Maximum Pressure 16 Bar
 Working Temperature -10°C to +232°C

Dimensions in mm

This data sheet is designed as a guide and should not be regarded as wholly accurate in every detail. We reserve the right to amend the specification of any product without notice.

N.	Part Name	Materials
1	Body	Cast Iron - ASTM A 126-B
2	Screen	Stainless Steel - 304
3	Bonnet	Cast Iron - ASTM A 126-B
4	Flange Gasket	Graphite
5	Screw	Cast Brass - ASTM B 16
6	Bolt	Steel

PN25 Ductile Iron "Y" Strainer

Features

- Flange Mounting PN25 Only
- Flange conforms to BS EN1092 PN25
- Conforms to BS EN558-1 Series 1

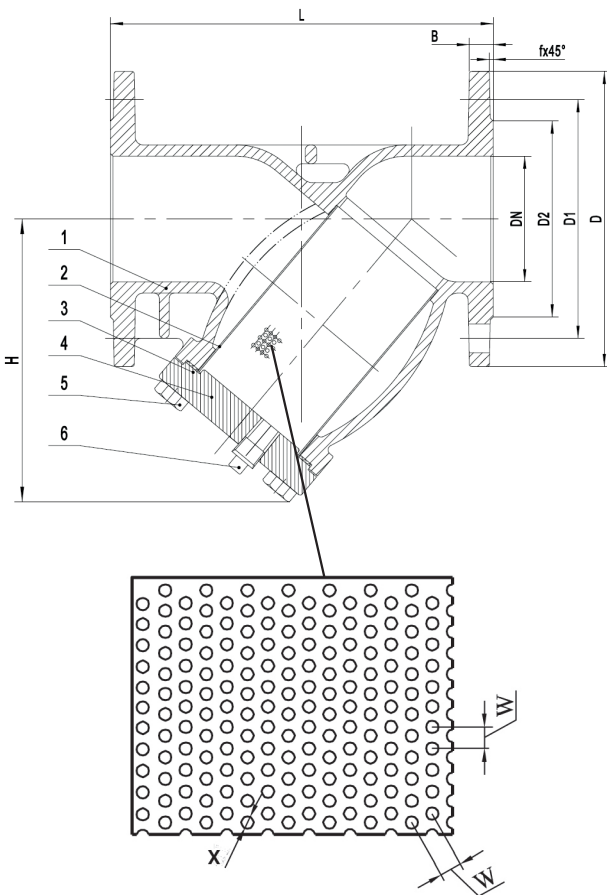

Pressure/Temperature

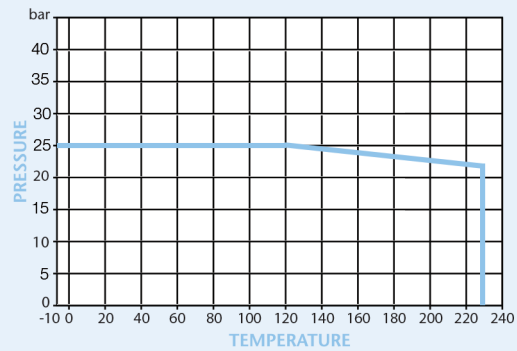

	2"	2½"	3"	4"	5"	6"	8"	10"	12"	14"	16"	18"	20"	24"
L	230	290	310	350	400	480	600	730	850	980	1100	1200	1250	1450
D	165	185	200	235	270	300	360	425	485	555	620	670	730	845
D1	125	145	160	190	220	250	310	370	430	490	550	600	660	770
D2	99	118	132	156	184	211	274	330	389	448	503	548	609	720
B	19	19	19	19	19	20	22	24.5	27.5	30	32	34.5	36.5	42
f	3	3	3	3	3	3	3	3	4	4	4	4	4	5
n-d	4-19	8-19	8-19	8-23	8-28	8-28	12-28	12-31	16-31	16-34	16-37	20-37	20-37	20-41
H	143	165	195	226	272	317	372	457	550	648	760	795	862	985
X	1.5	1.5	1.5	1.5	1.5	1.5	1.5	1.5	1.5	1.5	1.5	1.5	1.5	1.5
W	2.5	2.5	2.5	2.5	2.5	2.5	2.5	2.5	2.5	2.5	2.5	2.5	2.5	2.5
Kgs	9.3	12.4	15.3	26	32	46	70	122	172	335	479	523	658	1050

Technical Data

Maximum Pressure 25 Bar
 Working Temperature -10°C to +230°C

N.	Part Name	Materials
1	Body	Ductile Iron - BS1563 EN-GJS-450
2	Screen	Stainless Steel - BS970 304S15
3	Bonnet	Ductile Iron - BS1563 EN-GJS-450
4	Gasket	Non-Asbestos / EPDM
5	Bolt	Steel - BS970 43A
6	Screw Plug	Stainless Steel - BS970 304S15

Dimensions in mm

This data sheet is designed as a guide and should not be regarded as wholly accurate in every detail. We reserve the right to amend the specification of any product without notice.

PN16 Cast Iron Globe Valve

Features

- Flange Mounting PN16 Only
- BS EN558-1 Series 10
- Conforms to BS5152



Pressure / Temperature

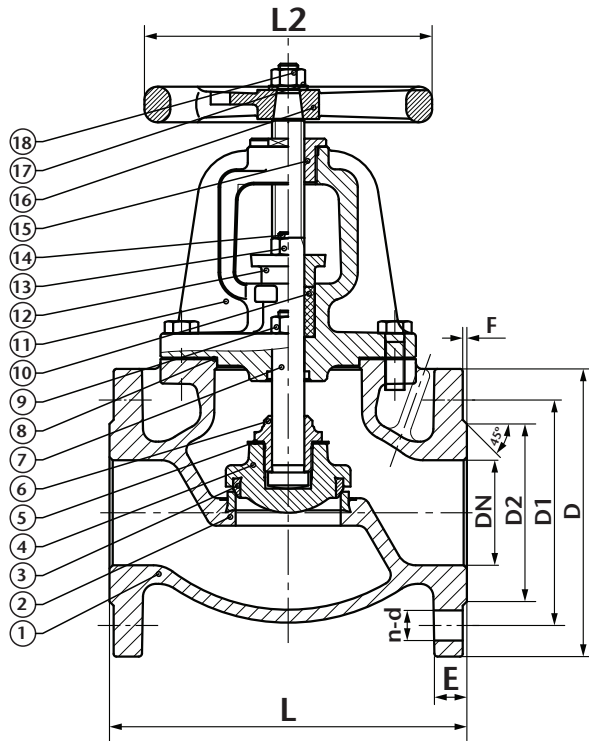
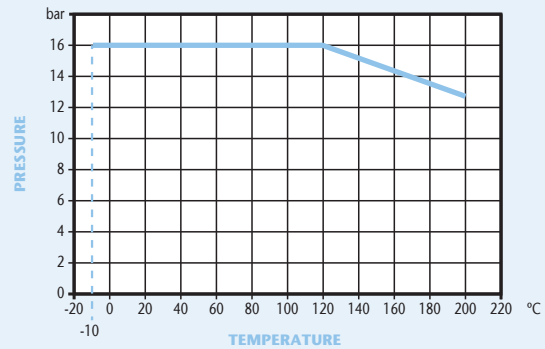

Technical Data	
Max Pressure	16 Bar
Working Temperature	-10°C to +200°C

Dimensions in mm

This data sheet is designed as a guide and should not be regarded as wholly accurate in every detail. We reserve the right to amend the specification of any product without notice.

DN	50	65	80	100	125	150	200	250	300
D	165	185	200	220	250	285	340	405	460
D1	125	145	160	180	210	240	295	355	410
D2	99	118	132	156	184	211	266	319	370
E	20	17.5	19.1	23.9	23.9	25.4	28.6	30.2	31.8
F	3	3	3	3	3	3	3	3	4
L	203	216	241	292	330	356	495	622	698
L2	178	178	200	254	300	300	348	400	457
n-d	4-19	4-19	8-19	8-19	8-19	8-23	12-23	12-28	12-28

N.	Part Name	Materials
1	Body	Cast Iron
2	Body Ring	Cast Bronze
3	Disc Ring	Cast Bronze
4	Disc	Cast Iron
5	Stop Washer	Stainless Steel 304
6	Nut	Cast Brass
7	Stem	Brass
8	Flange Gasket	Graphite
9	Bolt	Cast Iron
10	Packing	Graphite
11	Bonnet	Cast Iron
12	Gland	Ductile Iron
13	Nut	Steel
14	Bolt	Steel
15	Stem Nut	Cast Brass
16	Handwheel	Cast Iron
17	Washer	Steel
18	Nut	Steel

ANSI 125 Cast Iron Globe Valve

Features

- Flanged ANSI 125 (B16.1)
- Class 125 Rated
- OSY rising stem
- Conforms to ASME B16.10 & MSS SP-85



Pressure/Temperature

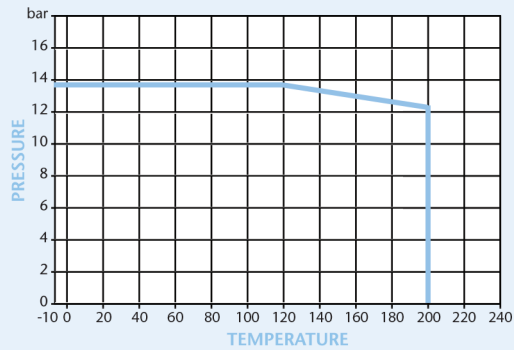

	2"	2½"	3"	4"	5"	6"	8"	10"	12"
L	203	216	241	292	330	356	495	622	699
D	152	178	190	229	254	279	343	406	483
D1	121	140	153	191	216	242	299	362	432
B	16	18	19	24	24	25	29	30	32
n-d	4 - 19	4 - 19	4 - 19	8 - 19	8 - 22	8 - 22	8 - 22	12 - 25	12 - 25
Do	178	178	200	254	300	300	348	400	457
Kgs	15.6	21.5	30.9	46.8	68.4	92.6	157	219	302

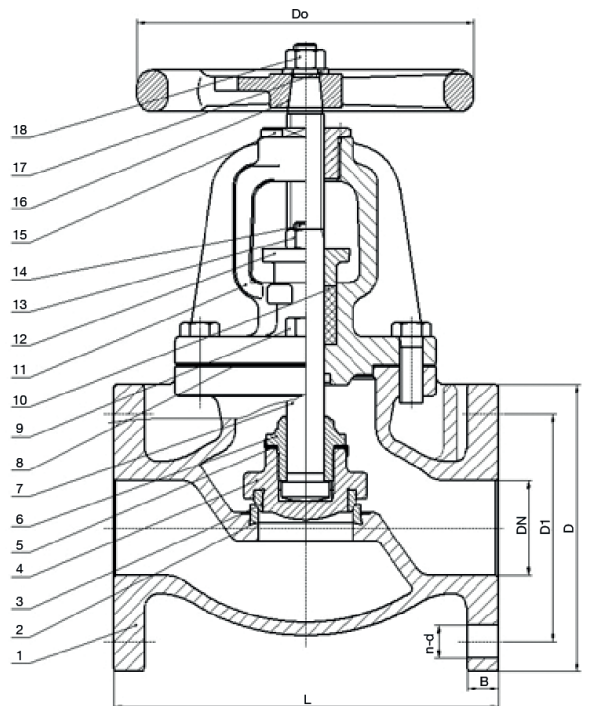

N.	Part Name	Materials
1	Body	Cast Iron - ASTM A 126-B
2	Body Seat Ring	Cast Bronze - ASTM B 62
3	Disc Seat Ring	Cast Bronze - ASTM B 62
4	Disc	Cast Iron - ASTM A 126-B
5	Washer	Stainless Steel - ASTM 304
6	Disc Nut	Cast Brass - Mn-Brass
7	Stem	Brass - ASTM B 16
8	Gasket	Graphite - Non-Asbestos
9	Bolt	Steel - ASTM A 307-B
10	Packing	Graphite - Non-Asbestos
11	Bonnet	Cast Iron - ASTM A 126-B
12	Packing Gland	Ductile Iron - ASTM A536 65-45-12
13	Nut	Steel
14	Bolt	Steel
15	Stem Nut	Cast Brass - Mn-Brass
16	Handwheel	Cast Iron - ASTM A 126-B
17	Washer	Steel
18	Nut	Steel - ASTM A 563-B

Technical Data

Max Pressure 13.8 Bar
 Working Temperature -10°C to +200°C

Dimensions in mm

This data sheet is designed as a guide and should not be regarded as wholly accurate in every detail. We reserve the right to amend the specification of any product without notice.

PN16 Cast Iron Gate Valve

Features

- Flange Mounting PN16 Only
- BS5150 (BS EN 558-1 Series 3)
- Non Rising Stem



Pressure/Temperature

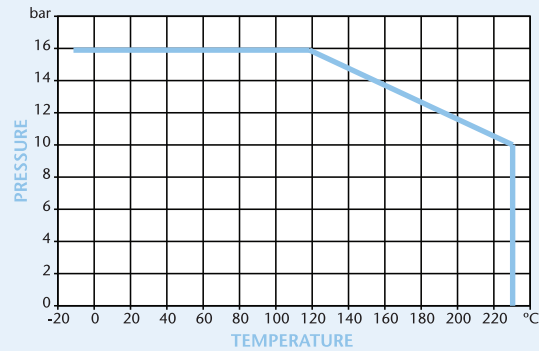

DN	50	65	80	100	125	150	200	250	300	350	400	450	500	600
L	178	190	203	229	254	267	292	330	356	381	406	432	457	508
D	165	185	200	220	250	285	340	405	460	520	580	640	715	840
D1	125	145	160	180	210	240	295	355	410	470	525	585	650	770
D2	99	118	132	156	184	211	266	319	370	429	480	548	609	720
B	20	20	22	24	26	26	30	32	32	36	38	40	42	48
f	3	3	3	3	3	3	3	3	4	4	4	4	4	5
n-d	4-19	4-19	8-19	8-19	8-19	8-23	12-23	12-28	12-28	16-28	16-31	20-31	20-34	20-37
H	302	332	335	423	485	545	644	769	860	987	1044	1148	1257	1418
kgs	16.5	21.6	26.5	47.2	68	87	118	197	275	370	460	635	800	1135

N.	Part Name	Materials
1	Body	Cast Iron - BS EN1561 EN-GJL-250
2	Body Sealed Ring	Cast Bronze - BS1400 LG2
3	Wedge Sealed Ring	Cast Bronze - BS1400 LG2
4	Wedge	Cast Iron - BS EN1561 EN-GJL-250
5	Stem Nut	Cast Brass - BS1400 PCB1
6	Stem	Stainless Steel - BS970 420S37
7	Gasket	Graphite
8	Bolt	Steel - BS970 43A
9	Nut	Steel - BS970 43A
10	Bonnet	Cast Iron - BS EN1561 EN-GJL-250
11	Studs	Steel - BS970 43A
12	Nut	Steel - BS970 43A
13	Stuffing Box Gasket	Graphite
14	Studs	Steel - BS970 43A
15	Stuffing Box	Cast Iron - BS EN1561 EN-GJL-250
16	Packing	Graphite
17	Gland Follower	Ductile Iron - BS EN1563 EN-GJS-450-10
18	Handwheel	Cast Iron - BS EN1561 EN-GJL-250
19	Washer	Steel - BS970 43A
20	Nut	Steel - BS970 43A

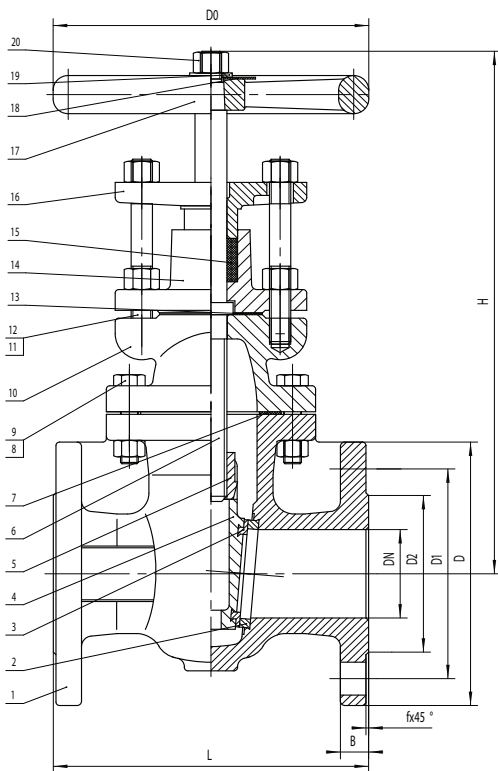

Technical Data

Maximum Pressure 16 Bar
Working Temperature -10°C to +230°C

Dimensions in mm

This data sheet is designed as a guide and should not be regarded as wholly accurate in every detail. We reserve the right to amend the specification of any product without notice.



PN25 Cast Iron Gate Valve

Features

- Flange Mounting PN25 Only
- Flange conforms to BS EN1092 PN25
- Conforms to BS5150 (BS EN558-1)
- Non Rising Stem

Pressure/Temperature

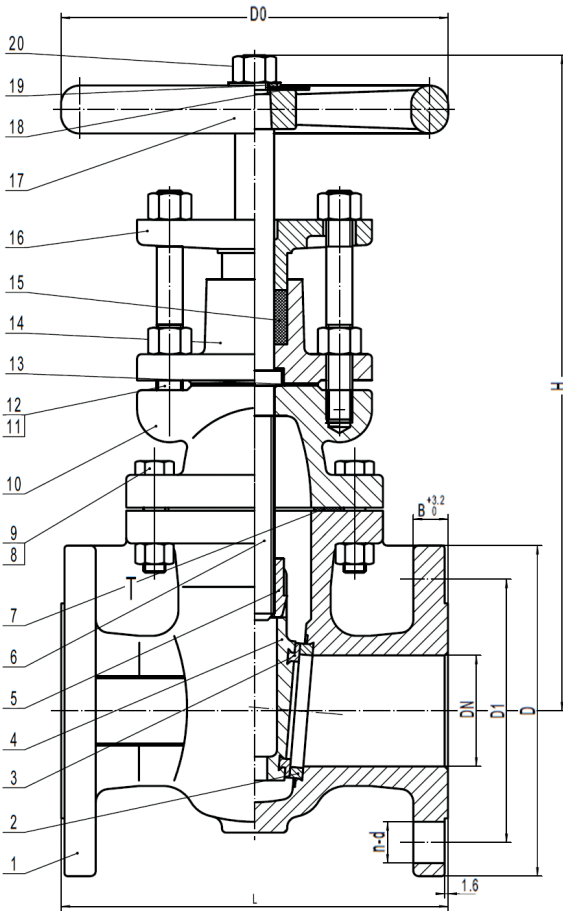
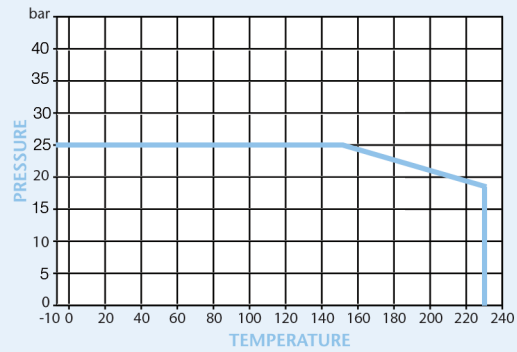

	2"	2½"	3"	4"	5"	6"	8"	10"	12"
L	216	241	283	305	381	403	419	457	502
D	165	191	210	254	279	318	381	445	521
D1	125	145	160	190	220	250	310	370	430
D2	99	118	132	156	184	211	274	330	389
f	3	3	3	3	3	3	3	3	4
B	22	25	29	32	35	37	41	48	51
n-d	4-19	8-19	8-19	8-23	8-28	8-28	12-28	12-31	16-31
d0	175	200	254	300	300	348	400	457	457
H	303	338	375	424	499	561	665	810	905
Kgs	17.1	23	27.5	47.7	70	89	126	208	289

Technical Data

Maximum Pressure 25 Bar
 Working Temperature -10°C to +230°C

N.	Part Name	Materials
1	Body	Cast Iron - BS EN1561 EN-GJL-250
2	Body Seat Ring	Cast Bronze - BS1400 LG2
3	Wedge Seat Ring	Cast Bronze - BS1400 LG2
4	Wedge	Cast Iron - BS EN1561 EN-GJL-250
5	Wedge Nut	Cast Brass - BS1400 PCB1
6	Stem	Brass - BS2874 CZ122
7	Gasket	Graphite
8	Bolt	Steel - BS970 43A
9	Nut	Steel - BS970 43A
10	Bonnet	Cast Iron - BS EN1561 EN-GJL-250
11	Gland Follower Bolt	Steel - BS970 43A
12	Nut	Steel - BS970 43A
13	Gasket	Graphite
14	Stuffing Box	Cast Iron - BS EN1561 EN-GJL-250
15	Packing	Graphite
16	Gland Follower	Ductile Iron - BS EN1563 EN-GJS-450-10
17	Handwheel	Cast Iron - BS EN1561 EN-GJL-250
18	Identification Plate	Aluminium
19	Washer	Steel - BS970 43A
20	Nut	Steel - BS970 43A

Dimensions in mm

This data sheet is designed as a guide and should not be regarded as wholly accurate in every detail. We reserve the right to amend the specification of any product without notice.

Cast Iron Gate Valve

Features

- Flanged ANSI 125 (B16.1)
- Class 125 Rated
- Non Rising Stem
- Conforms to ASME B16.10 & MSS SP-70

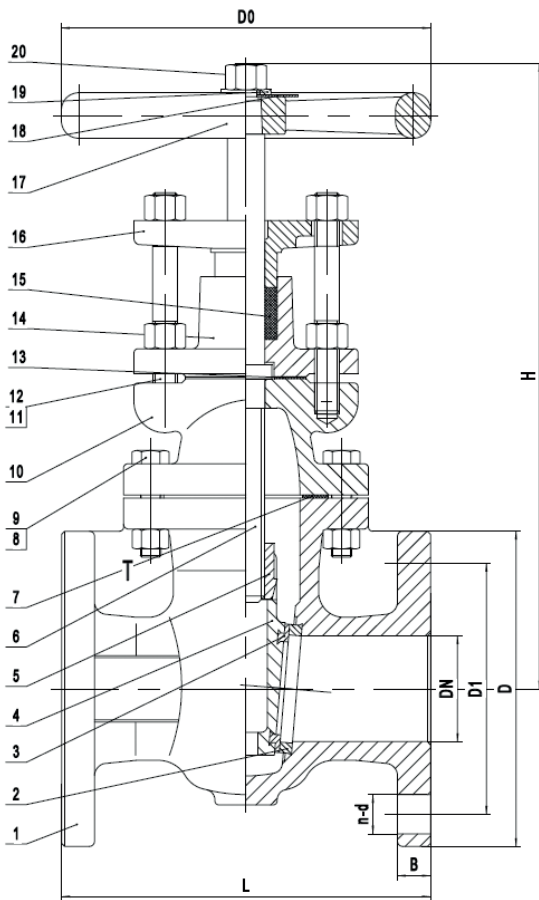

Technical Data

Maximum Pressure	13.8 Bar
Working Temperature	-10°C to +230°C

Dimensions in mm

This data sheet is designed as a guide and should not be regarded as wholly accurate in every detail. We reserve the right to amend the specification of any product without notice.

Pressure/Temperature

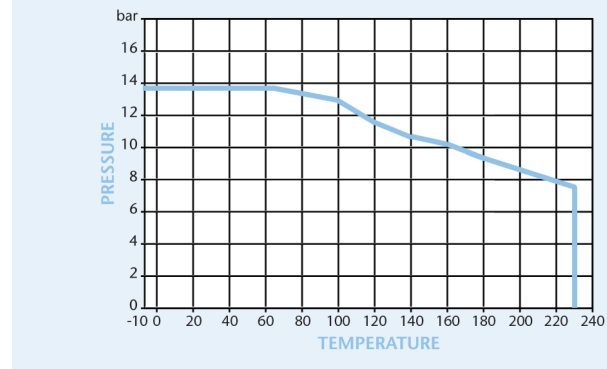

	2"	2½"	3"	4"	5"	6"	8"	10"	12"	14"	16"	18"	20"	24"
L	178	190	203	229	254	267	292	330	356	381	406	432	457	508
D	152	178	190	229	254	279	343	406	483	533	597	635	699	813
D1	121	140	153	191	216	241	299	362	432	476	540	578	635	750
B	16	18	19	24	24	25	29	30	32	35	37	40	43	48
n-d	4-19	4-19	4-19	8-19	8-22.2	8-22.2	8-22.2	12-25.4	12-25.4	12-28.6	16-28.6	16-32	20-32	20-35
D0	178	178	200	254	300	300	348	400	457	560	560	610	610	765
H	302	332	335	423	485	545	644	769	860	987	1044	1148	1257	1418
Kgs	16.5	21.6	26.5	47.2	68	87	118	197	275	370	462.5	635	800	1135

N.	Part Name	Materials
1	Body	Cast Iron - ASTM A 126-B
2	Body Seat Ring	Cast Bronze - ASTM B 62
3	Wedge Seat Ring	Cast Bronze - ASTM B 62
4	Wedge	Cast Iron - ASTM A 126-B
5	Wedge Nut	Cast Brass - Mn-Brass
6	Stem	Brass - ASTM B 16
7	Gasket	Graphite - Non-Asbestos
8	Bolt	Steel - ASTM A 307 B
9	Nut	Steel - ASTM A 563 B
10	Bonnet	Cast Iron - ASTM A 126-B
11	Gland Follower Bolt	Steel
12	Nut	Steel
13	Gasket	Graphite - Non-Asbestos
14	Stuffing Box	Cast Iron - ASTM A 126-B
15	Packing	Graphite - Non-Asbestos
16	Gland Follower	Ductile Iron - ASTM A 536 65-45-12
17	Handwheel	Cast Iron - ASTM A 126-B
18	Identification Plate	Aluminium
19	Washer	Steel
20	Nut	Steel - ASTM A 563 B

BS 10 Cast Iron Gate Valve

Features

- Flange Mounting BS10 Table 'E' and 'D'
- BS3464
- Non Rising Stem



Pressure/Temperature

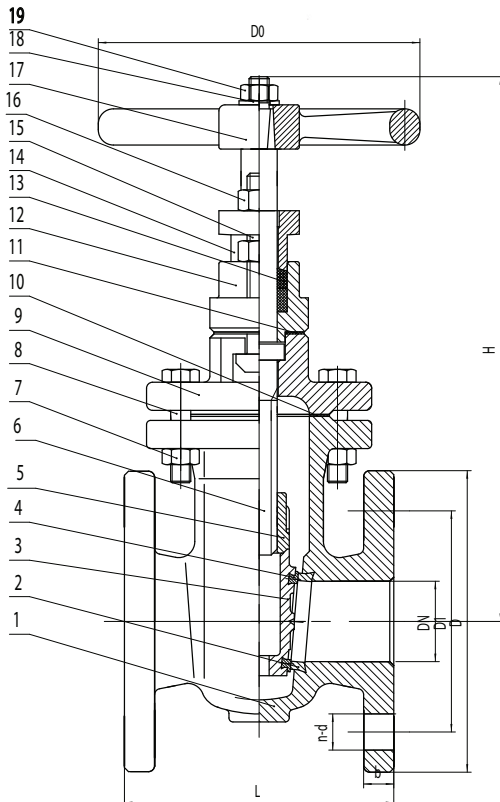
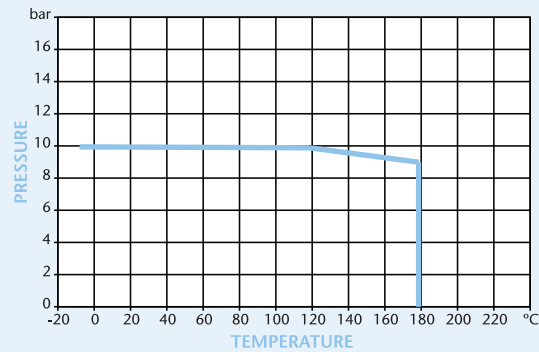

DN	50	65	80	100	125	150	200	250	300
L	146	159	165	171	190	210	241	273	305
D	155	175	185	210	250	280	330	400	445
D1	114	127	146	178	210	235	292	356	406
b	16	16	17	18	18	21	23	26	28
n-d	4-17.5	4-17.5	4-17.5	8-17.5	8-17.5	8-22.2	8-22.2	2-22.2	2-22.2
D0	160	160	160	200	250	250	250	320	320
H	292	324	360	380	454	490	578	711	767
Kgs	13.8	18.5	24.1	28.8	50	62	85.5	143	152

N.	Part Name	Materials
1	Body	Cast Iron GG25
2	Body Seald Ring	Cast Bronze
3	Wedge	Cast Iron
4	Wedge Seat Ring	Cast Bronze
5	Stem Nut	Cast Brass
6	Stem	Stainless Steel
7	Nut	Steel
8	Bolt	Steel
9	Bonnet	Cast Iron
10	Gasket	Graphite
11	Stuffing Box Gasket	Graphite
12	Stuffing Box	Cast Iron
13	Packing	Graphite
14	Gland Follower	Cast Iron
15	T-Bolt	Steel
16	Nut	Steel
17	Handwheel	Cast Iron
18	Washer	Steel
19	Nut	Steel

Technical Data

Maximum Pressure 10 Bar

Working Temperature -10°C to +180°C

Dimensions in mm

This data sheet is designed as a guide and should not be regarded as wholly accurate in every detail. We reserve the right to amend the specification of any product without notice.



PN25 Cast Iron Rising Stem Gate Valve

Features

- Flange Mounting PN25 Only
- Flange conforms to BS EN1092 PN25
- Conforms to BS5150 (BS EN558-1 series 4)
- OSY rising stem

Pressure/Temperature

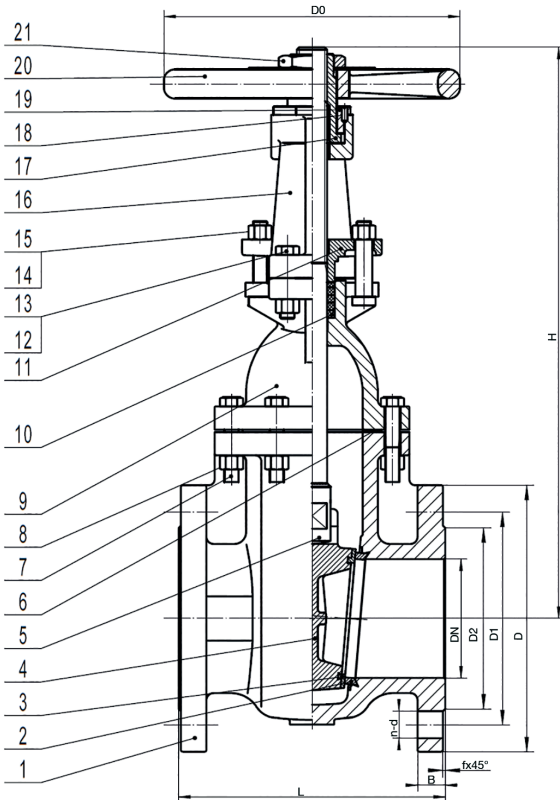
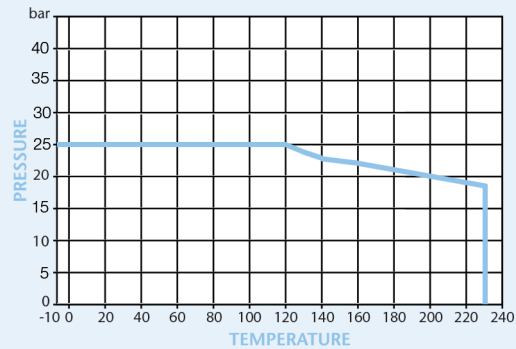

	2"	2½"	3"	4"	5"	6"	8"	10"	12"
L	216	241	283	305	381	403	419	457	502
D	165	191	210	254	279	318	381	445	521
D1	125	145	160	190	220	250	310	370	430
D2	99	118	132	156	184	211	274	330	398
B	22	25	29	32	35	37	41	48	51
n-d	4-19	8-19	8-19	8-23	8-28	8-28	12-28	12-31	16-31
D0	175	200	254	300	300	348	400	457	457
f	3	3	3	3	3	3	3	3	4
H (min)	325	362	406	493	579	644	795	935	1059
H (max)	385	437	493	611	716	813	1023.5	1211	1386
Kgs	17.8	23.3	28.2	45.8	69	86.2	125	206	278

N.	Part Name	Materials
1	Body	Cast Iron - BS1452 Gr.220
2	Seat Ring	Cast Bronze - BS1400 LG2
3	Seat Ring	Cast Bronze - BS1400 LG2
4	Wedge	Cast Iron - BS1452 Gr.220
5	Stem	Brass - BS2874 CZ122
6	Gasket	Graphite
7	Bolt	Steel - BS970 43A
8	Nut	Steel - BS970 43A
9	Bonnet	Cast Iron - BS1452 Gr.220
10	Packing	Graphite
11	Gland Follower	Ductile Iron - BS2789 Gr.420-12
12	Bolt	Steel - BS970 43A
13	Nut	Steel - BS970 43A
14	Bolt	Steel - BS970 43A
15	Nut	Steel - BS970 43A
16	Yoke	Cast Iron - BS1452 Gr.220
17	Yoke Bushing	Cast Brass - BS1400 PCB1
18	Screw	Steel - BS970 43A
19	Yoke Bushing Nut	Cast Iron - BS1452 Gr.220
20	Handwheel	Cast Iron - BS1452 Gr.220
21	Handwheel Nut	Steel - BS970 43A

Technical Data

Max Pressure 25 Bar
 Working Temperature -10°C to +230°C

Dimensions in mm

This data sheet is designed as a guide and should not be regarded as wholly accurate in every detail. We reserve the right to amend the specification of any product without notice.

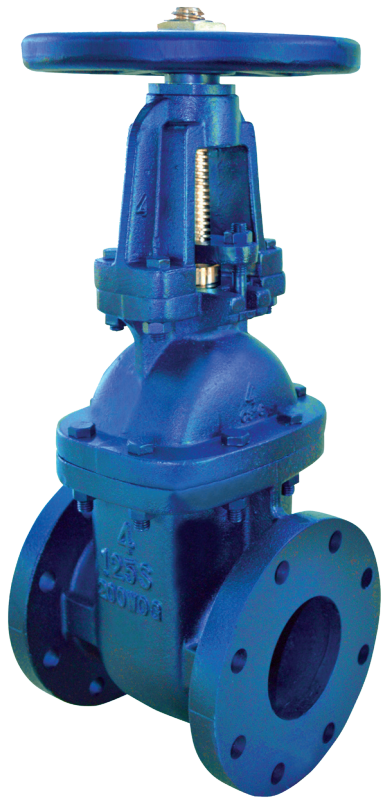

ANSI 125 Cast Iron Rising Stem Gate Valve

Features

- Flanged ANSI 125 (B16.1)
- Class 125 Rated
- OSY rising stem
- Conforms to ASME B16.10 & MSS SP-70

Pressure/Temperature

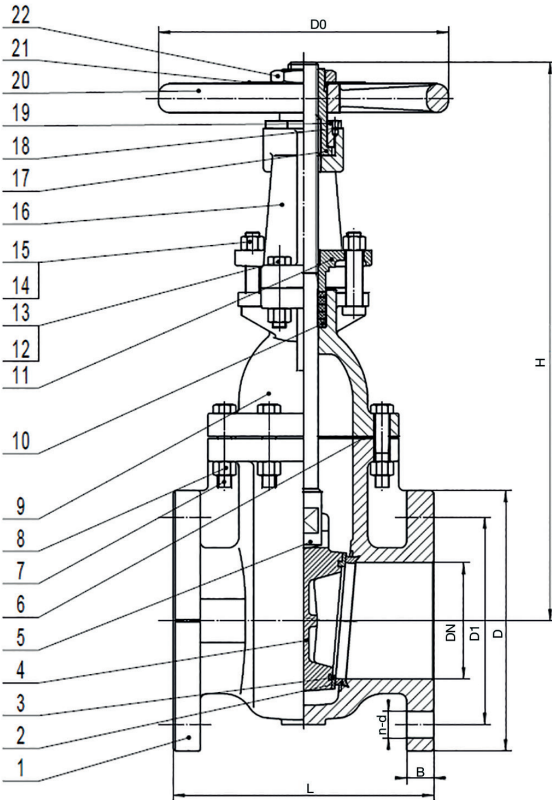
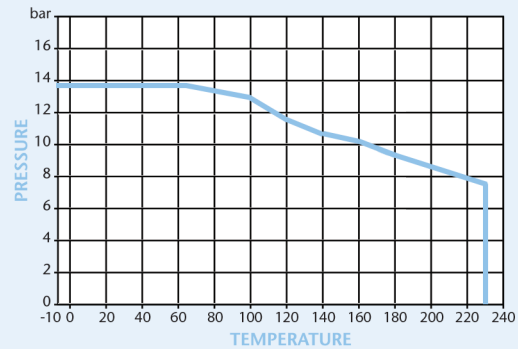

	2"	2½"	3"	4"	5"	6"	8"	10"	12"	14"	16"	18"	20"	24"
L	178	190	203	229	254	267	292	330	356	381	406	432	457	508
D	152	178	190	229	254	279	343	406	483	533	597	635	699	813
D1	121	140	153	191	216	241	299	362	432	476	540	578	635	750
B	16	18	19	24	24	25	29	30	32	35	37	40	43	48
n-d	4-	4-	4-	8-	8-	8-	8-	12-	12-	12-	16-	16-	20-	20-
	19	19	19	19	22.2	22.2	22.2	25.4	25.4	28.6	28.6	32	32	35
D0	178	178	200	254	300	300	348	400	457	560	560	610	610	765
H	311	347	384	490	541	656	778	933	1102	1259	1395	1560	1708	1990
Kgs	17.1	23	27.5	47.7	70	89	126	208	289	426	603	774	894	1294

N.	Part Name	Materials
1	Body	Cast Iron - ASTM A 126-B
2	Body Seat Ring	Cast Bronze - ASTM B 62
3	Wedge Seat Ring	Cast Bronze - ASTM B 62
4	Wedge	Cast Iron - ASTM A 126-B
5	Stem	Brass - ASTM B 16
6	Gasket	Graphite - Non-Asbestos
7	Bolt	Steel - ASTM A 307 B
8	Nut	Steel - ASTM A 563 B
9	Bonnet	Cast Iron - ASTM A 126-B
10	Packing	Graphite - Non-Asbestos
11	Gland Follower	Ductile Iron - ASTM A536 65-45-12
12	Bolt	Steel
13	Nut	Steel
14	Bolt	Steel
15	Nut	Steel
16	Yoke	Cast Iron - ASTM A 126-B
17	Stem Nut	Cast Brass - Mn-Brass
18	Screw	Steel
19	Nut	Cast Iron - ASTM A 126-B
20	Handwheel	Cast Iron - ASTM A 126-B
21	Identification Plate	Aluminium
22	Handwheel Nut	Steel

Technical Data

Max Pressure	13.8 Bar
Working Temperature	-10°C to +230°C

Dimensions in mm

This data sheet is designed as a guide and should not be regarded as wholly accurate in every detail. We reserve the right to amend the specification of any product without notice.



PN16 Cast Iron Rising Stem Gate Valve

Features

- Flange Mounting PN16 Only
- Flange conforms to BS EN1092 PN16
- Conforms to BS5150 (BS EN558-1 series 3)
- OSY rising stem

Pressure/Temperature

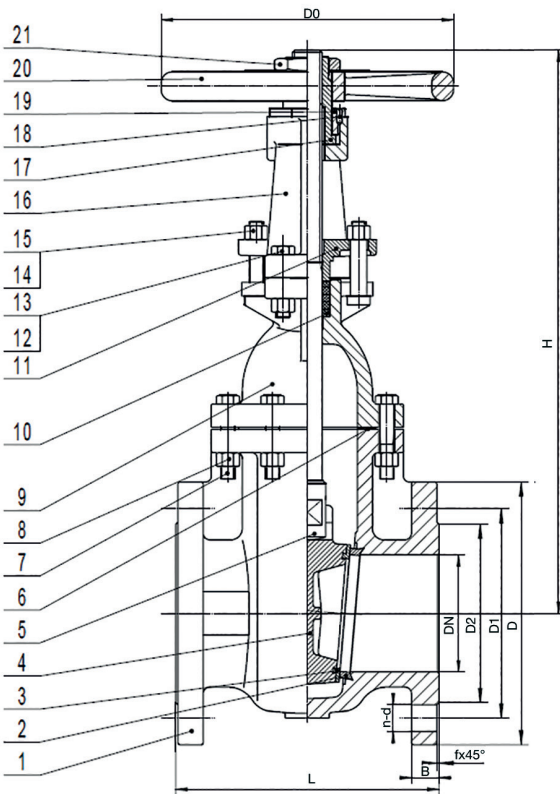
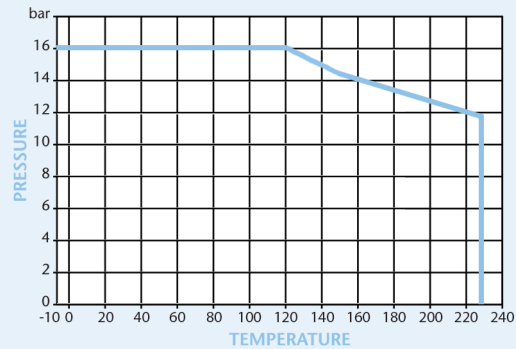

	2"	2½"	3"	4"	5"	6"	8"	10"	12"	14"	16"	18"	20"	24"
L	178	190	203	229	254	267	292	330	356	381	406	432	457	508
D	165	185	200	220	250	285	340	405	460	520	580	640	715	840
D1	125	145	160	180	210	240	295	355	410	470	525	585	650	770
D2	99	118	132	156	184	211	266	319	370	429	480	548	609	720
B	20	20	22	24	26	26	30	32	32	36	38	40	42	48
n-d	4-19	4-19	8-19	8-19	8-19	8-23	12-23	12-28	12-28	16-28	16-31	20-31	20-34	20-37
D0	178	178	200	254	300	300	348	400	457	560	560	610	610	765
f	3	3	3	3	3	3	3	3	4	4	4	4	4	5
H	311	347	384	490	541	656	778	933	1102	1259	1395	1560	1708	1990
Kgs	17.8	23.3	28.2	45.8	69	86.2	125	206	278	421	596	771	896	1300

N.	Part Name	Materials
1	Body	Cast Iron - BS EN1561 EN-GJL-250
2	Seat Ring	Cast Bronze - ASTM B62
3	Seat Ring	Cast Bronze - ASTM B62
4	Wedge	Cast Iron - BS EN1561 EN-GJL-250
5	Stem	Stainless Steel - BS970 420S37
6	Gasket	Graphite
7	Bolt	Steel - BS970 43A
8	Nut	Steel - BS970 43A
9	Bonnet	Cast Iron - BS EN1561 EN-GJL-250
10	Packing	Graphite
11	Gland Follower	Ductile Iron - BS EN1563 EN-GJS-450-10
12	Bolt	Steel - BS970 43A
13	Nut	Steel - BS970 43A
14	Gland Follower Bolt	Steel - BS970 43A
15	Nut	Steel - BS970 43A
16	Yoke	Cast Iron - BS EN1561 EN-GJL-250
17	Yoke Bushing	Cast Brass - BS1400 PCB1
18	Screw	Steel - BS970 43A
19	Yoke Bushing Nut	Cast Iron - BS EN1561 EN-GJL-250
20	Handwheel	Cast Iron - BS EN1561 EN-GJL-250
21	Handwheel Nut	Steel - BS970 43A

Technical Data

Max Pressure	16 Bar
Working Temperature	-10°C to +230°C

Dimensions in mm

This data sheet is designed as a guide and should not be regarded as wholly accurate in every detail. We reserve the right to amend the specification of any product without notice.

PN16 Ductile Iron Gate Valve

Features

- Flange Mounting PN16 Only
- BS EN 558-1 Series 14
- DIN 3352F4



Pressure/Temperature

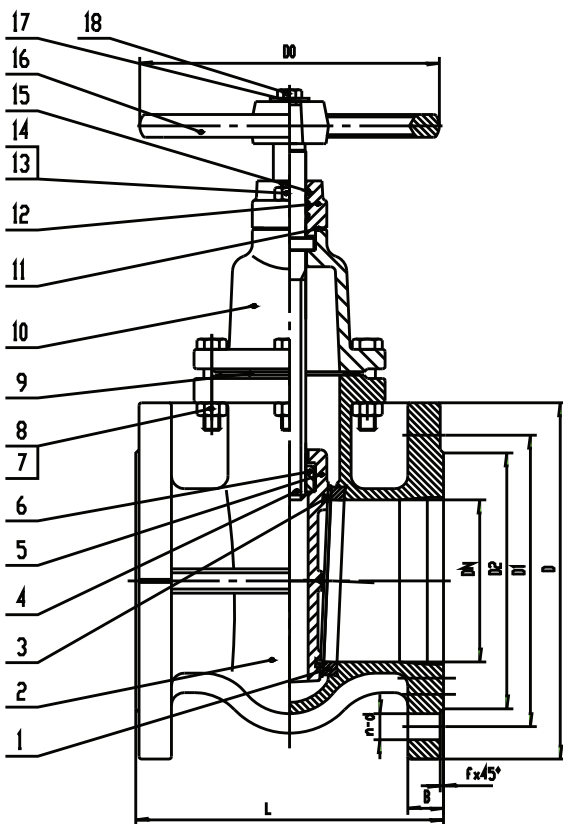
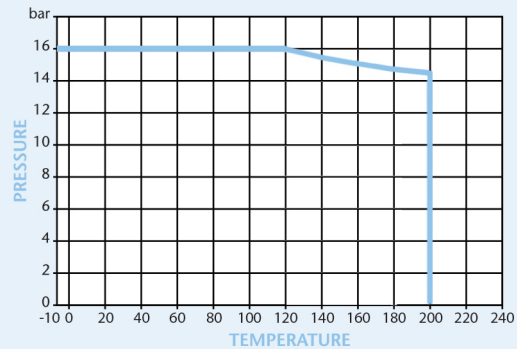

DN	50	65	80	100	125	150	200	250	300
L	150	170	180	190	200	210	230	250	270
D	165	185	200	220	250	285	340	405	460
D1	125	145	160	180	210	240	295	355	410
D2	102	124	140	158	188	212	268	320	378
B	16	16	17	17	18	20	21	23	24
f	2	2	2	2	3	3	3	3	4
n-d	4-19	4-19	8-19	8-19	8-19	8-23	12-23	12-28	12-28
D0	130	130	150	185	185	195	225	245	285
Kgs	10.8	12.8	16.6	22.8	32.1	42.9	71.3	98	145

Technical Data

Pressure	16 Bar
Working Temperature	-10°C to +200°C

Dimensions in mm

This data sheet is designed as a guide and should not be regarded as wholly accurate in every detail. We reserve the right to amend the specification of any product without notice.

N.	Part Name	Materials
1	Body Seat Ring	Cast Brass
2	Body	Ductile Iron
3	Wedge Seat Ring	Cast Brass
4	Stem	Stainless Steel
5	Wedge	Ductile Iron
6	Stem Nut	Cast Brass
7	Bolt	Steel
8	Nut	Steel
9	Flange Gasket	Graphite
10	Bonnet	Ductile Iron
11	Stuffing Box Gasket	Graphite
12	Stuffing Box	Ductile Iron
13	Bolt	Steel
14	Nut	Steel
15	O-Ring	NBR
16	Handwheel	Cast Iron
17	Washer	Steel
18	Bolt	Steel



Handwheel, gearbox or cap top operation

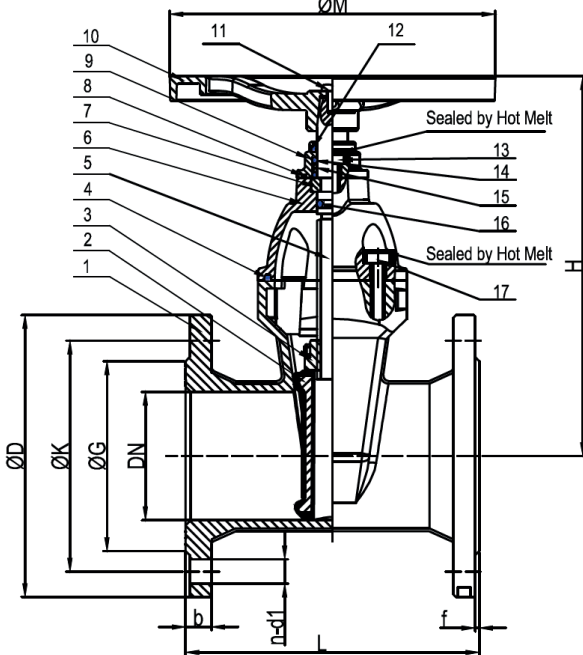
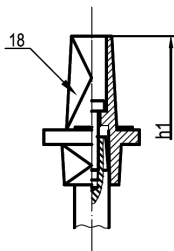

PN16 Ductile Iron Resilient Seat Gate Valve

Features

- BS5163, Type B cover and stem
- Non rising stem, clockwise closing
- Flange mounting to EN1092-2 PN16
- Face to face length to EN558-1 Series 3
- WRAS Approved
- Internally and externally fusion bonded epoxy coated

Pressure/Temperature

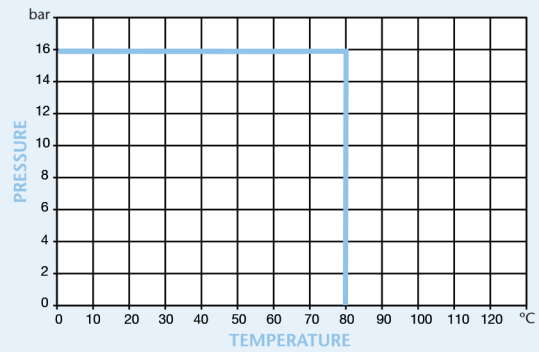

	1½"	2"	2½"	3"	4"	5"	6"	8"	10"	12"	14"	16"	18"	20"	24"
L	165	178	190	203	229	254	267	292	330	356	381	406	432	457	508
H	190	215	235	265	315	350	385	485	600	680	810	890	1050	1230	1260
M	200	200	200	254	254	315	315	315	406	406	500	500	500	650	650
h1	260	285	300	320	390	430	470	560	680	770	900	1000	1150	1330	1510
D	150	165	185	200	220	250	285	340	405	460	520	580	640	715	840
K	110	125	145	160	180	210	240	295	355	410	470	525	585	650	770
G	84	99	118	132	156	184	211	266	319	370	429	480	548	609	720
n-d1	4- Ø19	4- Ø19	4- Ø19	8- Ø19	8- Ø19	8- Ø19	8- Ø19	12- Ø23	12- Ø23	12- Ø28	16- Ø28	16- Ø31	20- Ø31	20- Ø34	20- Ø37
b	19	19	19	19	19	19	19	20	22	24.5	26.5	28	30	31.5	36
f	3	3	3	3	3	3	3	3	3	4	4	4	4	4	5
Kgs	7	9	12	14	19	24	31	52	87	116	185	225	360	450	690

N.	Part Name	Materials
1	Body	Ductile Iron GGG50 - BS2789
2	Disc	Ductile Iron GGG50 + EPDM (WRAS)-BS2789
3	Stem Nut	Brass HPb59-1 - BS2872-2874
4	Bonnet Gasket	EPDM (WRAS) - ISO4633
5	Stem	Stainless Steel 316 - BS970
6	Bonnet	Ductile Iron GGG50 - BS2789
7	Holding Ring	Brass HPb59-1 - BS2872-2874
8	O-Ring	EPDM (WRAS) - ISO4633
9	Gland	Ductile Iron GGG50 - BS2789
10	Hand Wheel	Ductile Iron GGG50 - BS2789
11	Screw	Stainless Steel 316 - BS970
12	Dust Ring	EPDM (WRAS) - ISO4633
13	Gland Bolts	Stainless Steel 316 - BS970
14	O-Ring	EPDM (WRAS) - ISO4633
15	Washers	Nylon 66
16	O-Ring	EPDM (WRAS) - ISO4633
17	Bonnet Bolts	Stainless Steel 316 - BS970
18	Cap Top	Ductile Iron GGG50 - BS2789

Technical Data

Maximum Pressure 16 Bar
Working Temperature 0°C to +80°C

Dimensions in mm

This data sheet is designed as a guide and should not be regarded as wholly accurate in every detail. We reserve the right to amend the specification of any product without notice.

PN25 Ductile Iron Resilient Seat Gate Valve

Features

- BS5163, Type B cover and stem
- Non rising stem, clockwise closing
- Flange mounting to EN1092-2 PN25
- Face to face length to EN558-1 Series 3
- WRAS Approved EPDM
- Internally and externally fusion bonded epoxy coated WRAS approved



Handwheel, gearbox or cap top operation

Pressure/Temperature

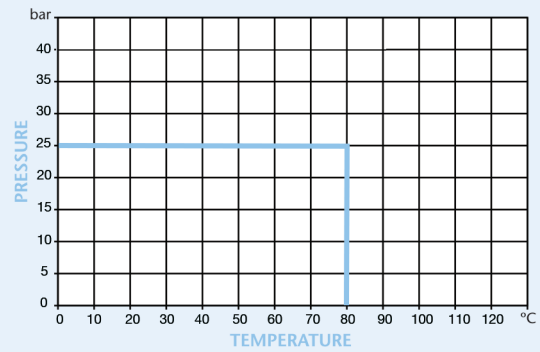

	2"	2½"	3"	4"	5"	6"	8"	10"	12"
L	178	190	203	229	254	267	292	330	356
H	215	235	265	315	350	385	485	600	680
M	200	200	254	254	315	315	315	406	406
h1	285	300	320	390	430	470	560	680	770
D	165	185	200	235	270	300	360	425	485
K	125	145	160	190	220	250	310	370	430
G	99	118	132	156	184	211	274	330	389
n-d1	4-Ø19	8-Ø19	8-Ø19	8-Ø23	8-Ø28	8-Ø28	12-Ø28	12-Ø31	16-Ø31
b	19	19	19	19	19	20	22	25	28
f	3	3	3	3	3	3	3	3	4
Kgs	9	12	14	19	24	31	52	87	116

N.	Part Name	Materials
1	Body	Ductile Iron GGG50 - BS2789
2	Disc	Ductile Iron GGG50 + EPDM (WRAS)-BS2789
3	Stem Nut	Brass HPb59-1 - BS2872-2874
4	Bonnet Gasket	EPDM (WRAS) - ISO4633
5	Stem	Stainless Steel 316 - BS970
6	Bonnet	Ductile Iron GGG50 - BS2789
7	Holding Ring	Brass HPb59-1 - BS2872-2874
8	O-Ring	EPDM (WRAS) - ISO4633
9	Gland	Ductile Iron GGG50 - BS2789
10	Hand Wheel	Ductile Iron GGG50 - BS2789
11	Screw	Stainless Steel 316 - BS970
12	Dust Ring	EPDM (WRAS) - ISO4633
13	Gland Bolts	Stainless Steel 316 - BS970
14	O-Ring	EPDM (WRAS) - ISO4633
15	Washers	Nylon 66
16	O-Ring	EPDM (WRAS) - ISO4633
17	Bonnet Bolts	Stainless Steel 316 - BS970
18	Cap Top	Ductile Iron GGG50 - BS2789

Technical Data

Maximum Pressure 25 Bar
Working Temperature 0°C to +80°C

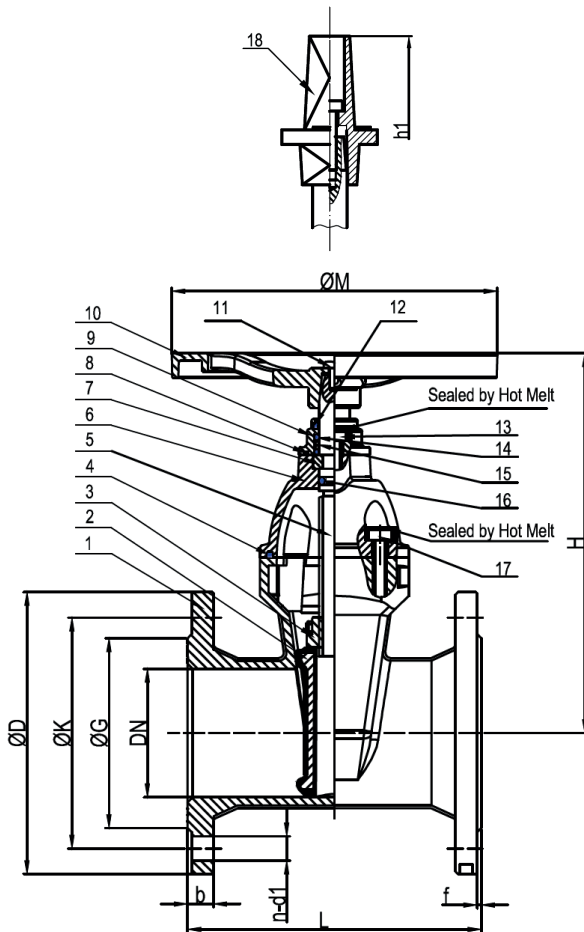

Dimensions in mm

This data sheet is designed as a guide and should not be regarded as wholly accurate in every detail. We reserve the right to amend the specification of any product without notice.

ANSI 125 Ductile Iron Resilient Seat Gate Valve

Features

- BS5163, Type B cover and stem
- Non rising stem, clockwise closing
- Flange mounting to ANSI 125 (B16.1)
- Face to face length to EN558-1 Series 3
- WRAS Approved EPDM
- Internally and externally fusion bonded epoxy coated WRAS approved



Handwheel, gearbox or cap top operation

Pressure/Temperature

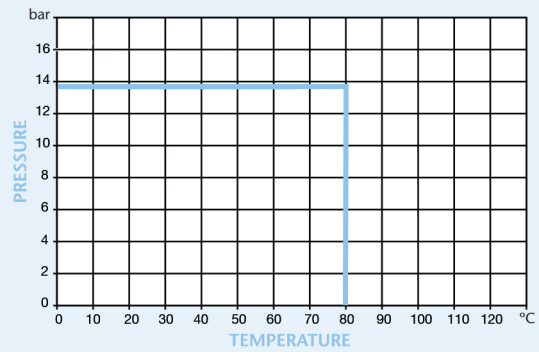

	2"	2½"	3"	4"	5"	6"	8"	10"	12"	14"	16"	18"	20"	24"
L	178	190	203	229	254	267	292	330	356	381	406	432	457	508
H	215	235	265	315	350	385	485	600	680	810	890	1050	1230	1260
M	200	200	254	254	315	315	315	406	406	500	500	500	650	650
h1	285	300	320	390	430	470	560	680	770	900	1000	1150	1330	1510
D	165	185	200	220	250	285	340	405	483	520	580	640	715	840
K	121	140	152	191	216	241	298	362	432	476	540	578	635	749
G	99	118	132	156	184	211	266	319	370	429	480	548	609	720
n-d1	4- Ø19	4- Ø19	4- Ø19	8- Ø19	8- Ø19	8- Ø22	8- Ø22	12- Ø25	12- Ø25	12- Ø28	16- Ø28	16- Ø32	20- Ø32	20- Ø35
b	19	19	19	19	19	19	20	22	24.5	26.5	28	30	31.5	36
f	3	3	3	3	3	3	3	3	4	4	4	4	4	5
Kgs	9	12	14	19	24	31	52	87	116	185	225	360	450	690

N.	Part Name	Materials
1	Body	Ductile Iron GGG50 - BS2789
2	Disc	Ductile Iron GGG50 + EPDM (WRAS)-BS2789
3	Stem Nut	Brass HPb59-1 - BS2872-2874
4	Bonnet Gasket	EPDM (WRAS) - ISO4633
5	Stem	Stainless Steel 316 - BS970
6	Bonnet	Ductile Iron GGG50 - BS2789
7	Holding Ring	Brass HPb59-1 - BS2872-2874
8	O-Ring	EPDM (WRAS) - ISO4633
9	Gland	Ductile Iron GGG50 - BS2789
10	Hand Wheel	Ductile Iron GGG50 - BS2789
11	Screw	Stainless Steel 316 - BS970
12	Dust Ring	EPDM (WRAS) - ISO4633
13	Gland Bolts	Stainless Steel 316 - BS970
14	O-Ring	EPDM (WRAS) - ISO4633
15	Washers	Nylon 66
16	O-Ring	EPDM (WRAS) - ISO4633
17	Bonnet Bolts	Stainless Steel 316 - BS970
18	Cap Top	Ductile Iron GGG50 - BS2789

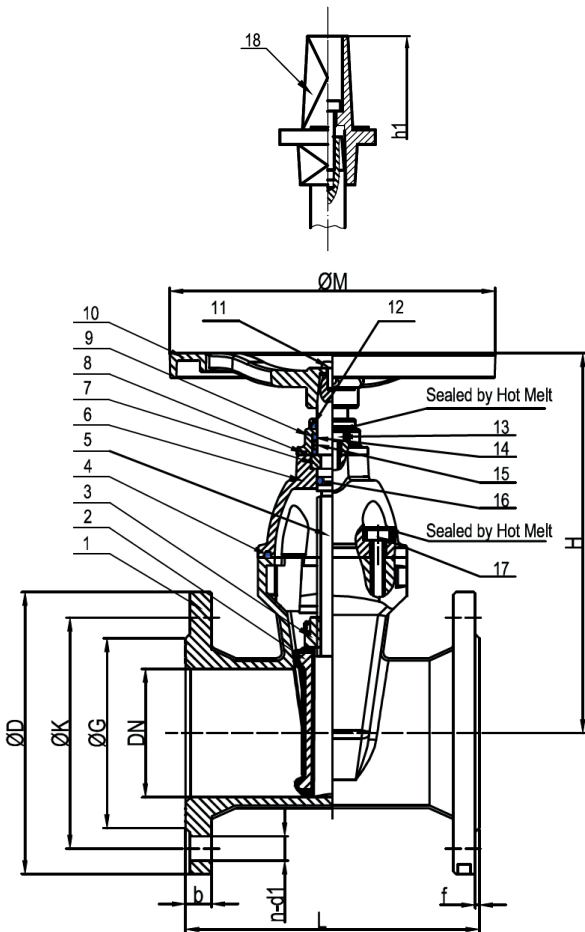

Technical Data

Maximum Pressure 13.8 Bar
Working Temperature 0°C to +80°C

Dimensions in mm

This data sheet is designed as a guide and should not be regarded as wholly accurate in every detail. We reserve the right to amend the specification of any product without notice.

Ductile Iron PN16 Flanged Double Check Valve

Features

- Flange mounting PN16 only (EN 1092-2)
- Epoxy coat finish
- Operates in any position
- WRAS Approved as a non-return valve



Pressure / Temperature

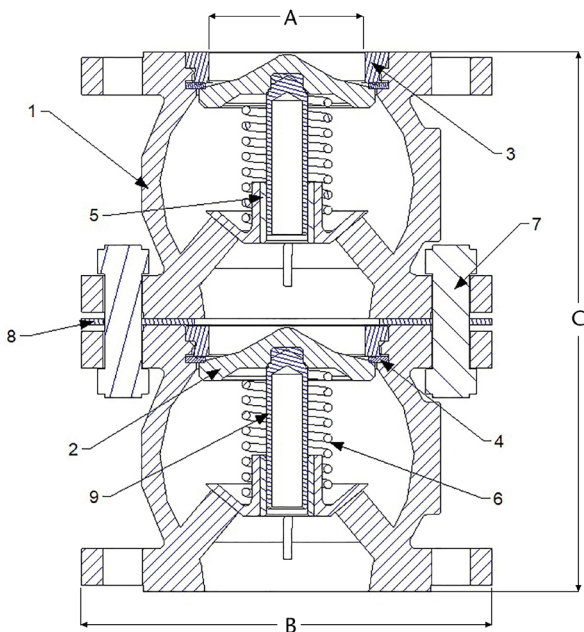
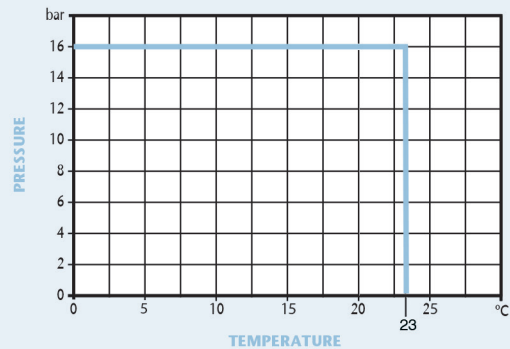

DN	50	65	80	100	125	150	200	250
A	50	65	80	100	125	150	200	250
B	165	185	200	220	250	285	340	405
C	205	245	265	315	405	465	565	693
Kgs	12	16.2	17.2	25	40	60	100	188

N	Part Name	Material
1	Body	Ductile Iron SG 420/12
2	Plunger Top	Delrin 150
3	Sealing Ring	Delrin 150
4	Seal	Nitrile 70 Shore
5	Guide Bush	Cz132 DZR Brass
6	Spring	Stainless Steel Grade 304 S26
7	Studs	Mild Steel (Plated)
8	Gasket	Nitrile 70 Shore
9	Plunger Shaft	Cz132 DZR Brass

Technical Data

Maximum Pressure 16 Bar
 Working Temperature 0°C to +23°C

Dimensions in mm

This data sheet is designed as a guide and should not be regarded as wholly accurate in every detail. We reserve the right to amend the specification of any product without notice.

PN16 Ductile Iron Foot Valve

Features

- Flange conforms to BS EN1092 PN16
- Valve design conforms to BS EN12334
- Valve inspection and testing in accordance with BS EN12266



Pressure/Temperature

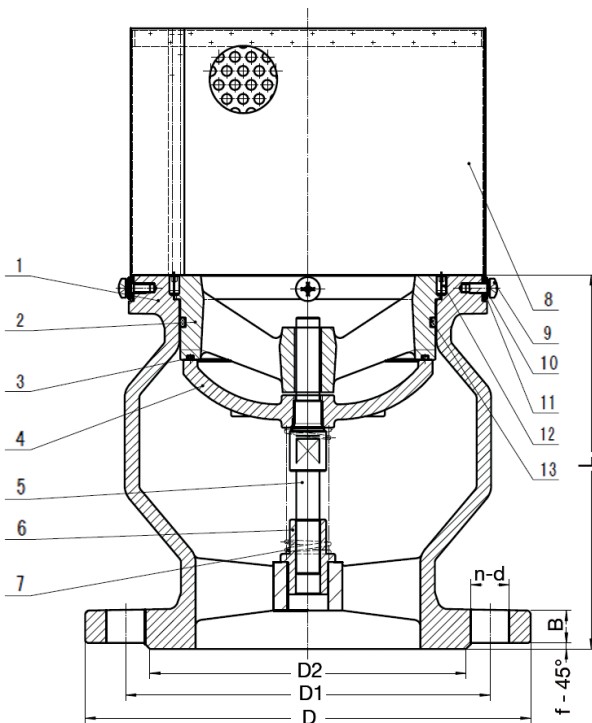
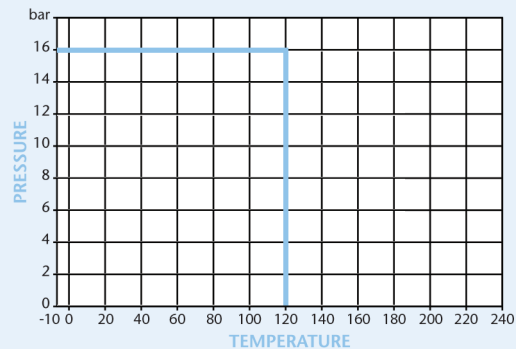

	2"	2½"	3"	4"	5"	6"	8"	10"	12"	14"	16"
L	133	140	152	185	216	230	259	362	393	400	448
D	165	185	200	220	250	285	340	405	460	520	580
D1	125	145	160	180	210	240	295	355	410	470	525
D2	99	118	132	156	184	211	266	319	370	429	480
B	19	19	19	19	19	19	20	22	25	27	28
f	3	3	3	3	3	3	3	3	4	4	4
n-d	4-19	4-19	8-19	8-19	8-19	8-23	12-23	12-28	12-28	16-28	16-31
Kgs	6.7	8.1	9.3	13.1	17.9	24.2	39.6	69	89.6	138.1	190.4

Technical Data

Max Pressure	16 Bar
Working Temperature	-10°C to +120°C

Dimensions in mm

This data sheet is designed as a guide and should not be regarded as wholly accurate in every detail. We reserve the right to amend the specification of any product without notice.

N.	Part Name	Materials
1	Body	Ductile Iron - BS EN1563 EN-GJS-450-10
2	Seat Body	Ductile Iron - BS EN1563 EN-GJS-450-10
3	Seat	EPDM
4	Disc	Ductile Iron - BS EN1563 EN-GJS-450-10
5	Stem	Stainless Steel - BS970 304S15
6	Bushing	Brass - BS2874 CZ122
7	Spring	Stainless Steel - BS970 304S15
8	Screen	Stainless Steel - BS970 304S15
9	Screw	Stainless Steel - BS970 304S15
10	Washer	Stainless Steel - BS970 304S15
11	Washer	Stainless Steel - BS970 304S15
12	Screw	Stainless Steel - BS970 304S15
13	Seat	EPDM



Certificate No. 1437B



Certificate No. 1437A

Distributor