

ANSI Adjustable Pressure Relief / Sustaining Valve

Features

- Automatic Control Valve
- Suitable for potable water applications
- WRAS approved epoxy coated body
- Pressure adjusted by Integral Pilot Valve
- Conforms to BS EN 558-1 Series 1
- Flange conforms to ANSI 150 (B16.42)
- Stainless steel pilot tubing and valves

Pressure/Temperature

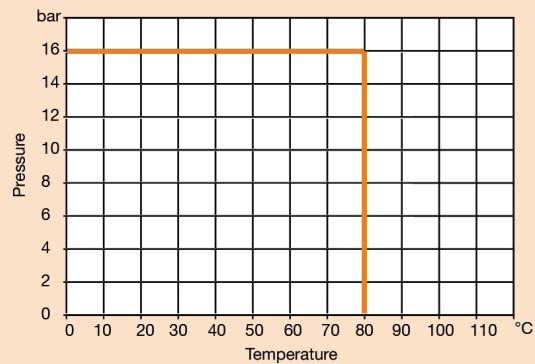

DN	50	65	80	100	125	150	200	250	300
L	230	290	310	350	400	480	600	730	850
E	152.4	177.8	190.5	228.6	254.0	279.4	342.9	406.4	482.6
C	120.7	139.7	152.4	190.5	215.9	241.3	298.5	362.0	431.8
n-d	4- Ø19	4- Ø19	4- Ø19	8- Ø19	8- Ø22.4	8- Ø22.4	8- Ø22.4	12- Ø25.4	12- Ø25.4
B	270	290	305	325	355	390	435	500	565
H	485	505	520	540	570	605	660	725	780
H1	402	412	420	430	445	463	491	523	651
Kgs	13	17	23	30	65	69	132	315	420

N.	Part Name	Materials
1	Body	Ductile Iron
2	Stem	Stainless Steel 304
3	Seat	Stainless Steel 304
4	O-Ring	NBR
5	Disc Ring	NBR
6	Disc Retailer	Ductile Iron
7	Disc Guide	Ductile Iron
8	Diaphragm	NBR + Nylon
9	Diaphragm Washer	Ductile Iron
10	Spring	Stainless Steel 304
11	Cover Bearing	Stainless Steel 304
12	Screw	Stainless Steel 304
13	Washer	Stainless Steel 304
14	Cover	Ductile Iron
15	Strainer	Stainless Steel 304
16	Ball Valve	Stainless Steel 304
17	Gauge	Stainless Steel 304
18	Needle Valve	Stainless Steel 304
19	Pilot Valve	Stainless Steel 304
20	Ball Valve	Stainless Steel 304

Technical Data

Max Pressure	16 Bar
Working Temperature	0°C to +80°C

Dimensions in mm

This data sheet is designed as a guide and should not be regarded as wholly accurate in every detail. We reserve the right to amend the specification of any product without notice.

Pilot Valve Detail

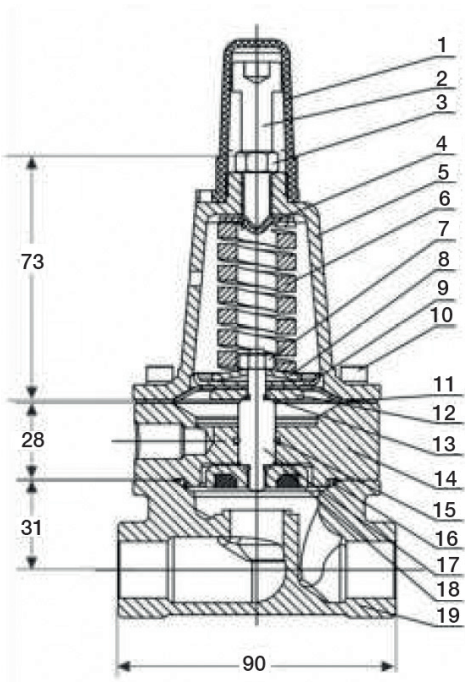

Pilot Valve

N.	Part Name	Materials
1	Cap	ABS
2	Adjusting Screw	Stainless Steel 304
3	Locking Nut	Stainless Steel 304
4	Upper Spring Holder	Stainless Steel 304
5	Cover	Stainless Steel 304
6	Spring	Stainless Steel 304
7	Nut	Stainless Steel 304
8	Lower Spring Holder	Stainless Steel 304
9	Diaphragm Washer	Stainless Steel 304
10	Screw	Stainless Steel 304
11	Diaphragm	NBR + Nylon
12	Disc Holder	Stainless Steel 304
13	O-Ring	NBR
14	Guide	Stainless Steel 304
15	O-Ring	NBR
16	O-Ring	NBR
17	Stem	Stainless Steel 304
18	Disc	Stainless Steel 304 + NBR
19	Body	Stainless Steel 304

Fitted with standard Pilot Valve
0.70 to 12.00 Bar (10 to 175 PSI)

Flow curve of the main valve at fully open status

