

DZR Brass Float Valve

Features

- Screwed BSP Parallel (ISO 228/1)
- Supplied with locknut
- Machined fixed flange on valve body
- All DZR brass bodies
- DZR long and short arm options
- No jam single lever action
- Replaceable seals
- Copper and plastic float option available

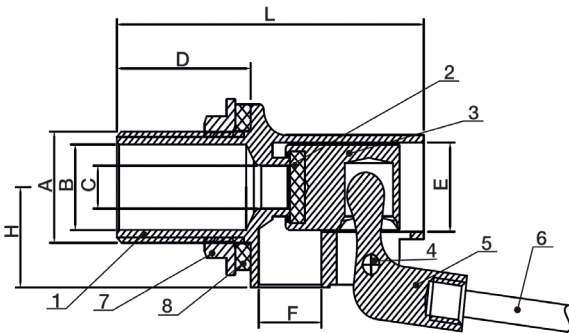
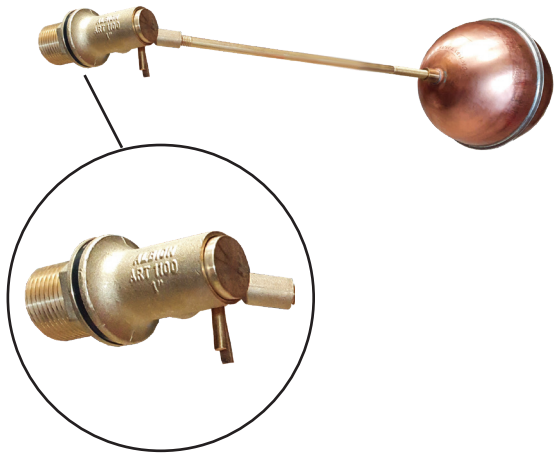

Arms - DZR with threads on both ends

Model	A	B	C
End #1 Thread	M8	M10	M12*1.75
Length	254	305	432
End #2 Thread	M8	M10	M12*1.75
Kgs	0.09	0.18	0.38

Plastic floats - Polyethylene

Diameter Size	4 1/2"	5"	6"	8"	10"
Thread Connection	M8	M8	M10	M12*1.75	M12*1.75
Kgs	0.08	0.13	0.18	0.37	0.67

Copper floats

Diameter Size	4 1/2"	5"	6"	8"	10"
Thread Connection	M8	M8	M10	M12*1.75	M12*1.75
Kgs	0.15	0.18	0.28	0.58	0.85

Technical Data

Max Pressure	16 Bar
Working Temperature	-20°C to +90°C

Dimensions in mm

This data sheet is designed as a guide and should not be regarded as wholly accurate in every detail. We reserve the right to amend the specification of any product without notice.

Pressure / Temperature

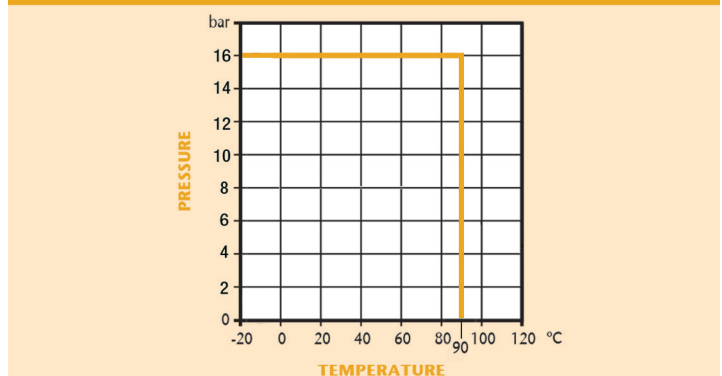

DN	1/2"	3/4"	1"	1 1/4"	1 1/2"	2"
B	16	20.5	25	32	40	50
C	8	8	14	19	19	25
D	30.5	32.5	35.5	82.5	82.5	82.5
E	16.7	16.7	26.3	34.3	34.3	50.3
F	14.3	14.3	18.5	32	32	32
H	18.8	20.8	28.8	42.3	42.3	53.0
L	70.0	74.5	87.5	168.5	168.5	168.5
Float Size	4 1/2"	5"	6"	8"	10"	10"
Arm Type	A	A	B	C	C	C
Kgs (valve)	0.32	0.42	0.81	1.80	2.18	2.25

N.	Part Name	Materials
1	Body	DZR Brass CW602N
2	Washer	EPDM
3	Piston	DZR Brass CW602N
4	Pin	Brass H59-1
5	Plunger	DZR Brass CW602N
6	Arm	DZR Brass CW602N
7	Back Nut	DZR Brass CW602N
8	Washer	EPDM

Flow Specifications

Flow	Pressure	Flow	Pressure	Flow
1/2"	50psi	20 gpm	100psi	31 gpm
3/4"	50psi	40 gpm	100psi	60 gpm
1"	50psi	100 gpm	100psi	150 gpm
1 1/2" - 2"	50psi	250 gpm	100psi	348 gpm