

Pressure Control Valves

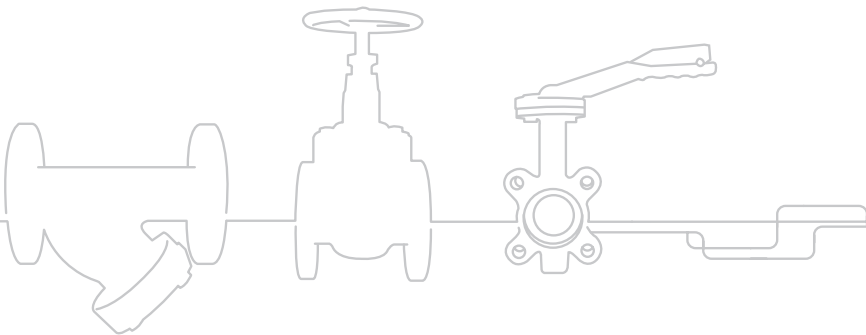

Product Information





Gunmetal Safety Valve

Features

- Screwed BSP Parallel (ISO 228)
- Body Gunmetal
- Suitable for Gases and Liquids
- Fitted with Diaphragm to Protect Spring Housing
- Set Range 0.5 to 16 Bar
- WRAS Approved
- ISO 4126-1, PED 2014/68/EU
- Marine Approvals - GL, DNV
- ATEX Approval Available at Extra Cost
- 5 Year Warranty
- Test Certificate to EN10204-3.1 Available on Request

Typical Applications

- Pressure Vessels
- Mechanical engineering
- Pump protection
- Pressure booster systems water/air-side
- Cooling/Chilling Systems
- Steam and industrial boiler systems

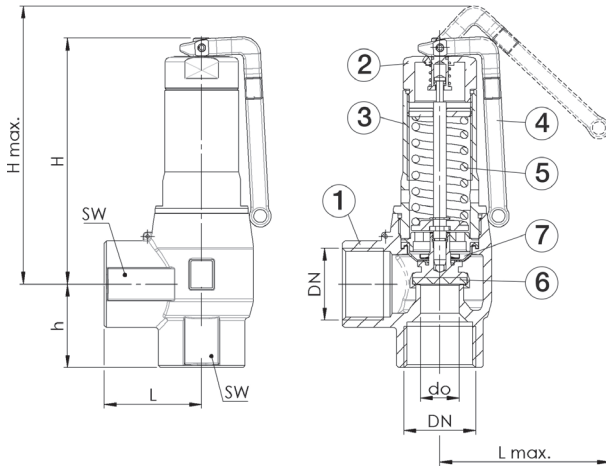

DN	1/2"	3/4"	1"	1 1/4"	1 1/2"	2"	2 1/2"
L	35	42	45	47	58	68	80
Lmax	63	75	78	100	140	150	155
H	90	106	120	150	192	229	275
Hmax	102	120	133	153	210	252	298
h	28	36	38	37	45	55	65
SW	27	34	41	50	60	70	90
do	13	15	18	23	30	39	48
kg	0.5	0.8	1.1	1.7	3.3	5.8	8.9

Technical Data

Max Pressure	16 Bar
Working Temperature	EPDM Diaphragm -50°C to +195°C

N.	Part Name	Materials
1	Body	Gunmetal
2	Housing Cap	Brass / Gunmetal
3	Spring Housing	Brass / Gunmetal
4	Lifting Lever	Stainless Steel CF8M
5	Spring	Stainless Steel 302
6	Seat-Seal	PTFE
7	Diaphragm	EPDM

Dimensions in mm

This data sheet is designed as a guide and should not be regarded as wholly accurate in every detail. We reserve the right to amend the specification of any product without notice.

Nm³/h - Air
 Kg/h - Steam
 M³/h - Water
 Kw - Heating Water

Discharge Capacities

DN Bar	1/2"				3/4"				1"				1 1/4"			
	Nm ³ /h	kg/h	m ³ /h	kW	Nm ³ /h	kg/h	m ³ /h	kW	Nm ³ /h	kg/h	m ³ /h	kW	Nm ³ /h	kg/h	m ³ /h	kW
0.5	76	62	2.3	38	101	83	3.1	51	143	117	4.3	72	234	191	7.0	118
1	110	88	3.2	54	147	117	4.2	71	207	165	5.8	101	338	269	9.5	164
2	180	142	4.5	85	240	189	6.0	113	340	268	8.2	160	556	437	13.5	262
3	248	193	5.5	114	330	257	7.3	152	468	365	10.1	215	764	595	16.5	352
4	312	242	6.4	141	416	322	8.5	188	592	458	11.7	267	966	748	19.1	436
5	376	290	7.1	167	501	386	9.5	223	712	549	13.1	316	1163	896	21.3	517
6	440	337	7.8	193	586	449	10.4	256	833	639	14.3	365	1359	1043	23.4	595
7	503	385	8.4	218	670	513	11.2	290	953	729	15.5	412	1556	1190	25.2	673
8	567	432	9.0	242	755	576	12.0	323	1074	819	16.5	459	1753	1337	27.0	749
9	631	480	9.6	267	840	639	12.7	355	1194	908	17.5	505	1950	1483	28.6	825
10	694	527	10.1	291	925	702	13.4	387	1315	998	18.5	550	2147	1629	30.2	899
11	758	574	10.6	315	1009	765	14.1	419	1435	1088	19.4	595	2343	1776	31.7	972
12	822	622	11.1	338	1094	828	14.7	450	1556	1177	20.2	640	2540	1922	33.1	1045
13	885	669	11.5	361	1179	891	15.3	481	1676	1266	21.1	684	2737	2068	34.4	1116
14	949	716	11.9	384	1264	954	15.9	511	1797	1356	21.9	727	2934	2214	35.7	1187
15	1013	764	12.4	407	1348	1017	16.5	542	1917	1446	22.6	770	3130	2361	37.0	1257
16	1076	811	12.8	429	1433	1080	17.0	571	2038	1535	23.4	813	3327	2507	38.2	1327

DN Bar	1 1/2"				2"				2 1/2"			
	Nm ³ /h	kg/h	m ³ /h	kW	Nm ³ /h	kg/h	m ³ /h	kW	Nm ³ /h	kg/h	m ³ /h	kW
0.5	338	276	10.5	170	571	466	17.7	288	864	706	26.8	436
1	491	392	14.3	239	831	662	24.1	404	1258	1003	36.5	612
2	816	642	20.2	385	1379	1085	34.2	650	2089	1643	51.8	985
3	1128	879	24.8	520	1907	1486	41.9	878	2888	2251	63.5	1330
4	1430	1107	28.7	646	2417	1872	48.4	1092	3661	2835	73.4	1654
5	1721	1326	32.1	765	2909	2241	54.2	1293	4407	3395	82.1	1958
6	2013	1544	35.1	882	3402	2609	59.4	1490	5153	3953	89.9	2257
7	2304	1762	37.9	996	3894	2977	64.1	1684	5899	4510	97.1	2551
8	2595	1979	40.6	1109	4386	3344	68.6	1875	6644	5066	103.9	2840
9	2887	2196	43.0	1221	4879	3711	72.7	2063	7390	5621	110.2	3125
10	3178	2412	45.4	1331	5371	4077	76.7	2249	8136	6175	116.1	3407
11	3469	2629	47.6	1439	5863	4443	80.4	2433	8882	6730	121.8	3685
12	3761	2845	49.7	1547	6356	4809	84.0	2614	9627	7284	127.2	3959
13	4052	3061	51.7	1652	6848	5174	87.4	2793	10373	7837	132.4	4230
14	4343	3278	53.7	1758	7340	5541	90.7	2970	11119	8393	137.4	4500
15	4635	3495	55.6	1862	7833	5907	93.9	3146	11865	8948	142.3	4766
16	4926	3711	57.4	1964	8325	6272	97.0	3319	12611	9501	146.9	5028

Seat-Seal/Diaphragm Options

Option	Materials	Type	Working Temp.
PTFE/EPDM	Polytetrafluorethylen/Ethylen-Propylene-Diene (Standard)	Flat seal and moulded diaphragm	-50°C to +195°C
EPDM/EPDM	Ethylen-Propylene-Diene/Ethylen-Propylene-Diene	Flat seal and moulded diaphragm	-50°C to +150°C
PTFE/FKM	Polytetrafluorethylen/Fluorcarbon	Flat seal and moulded diaphragm	-30°C to +200°C
FKM/FKM	Fluorcarbon/Fluorcarbon	Elastomere seals and moulded diaphragm	-20°C to +200°C

Dimensions in mm

This data sheet is designed as a guide and should not be regarded as wholly accurate in every detail. We reserve the right to amend the specification of any product without notice.

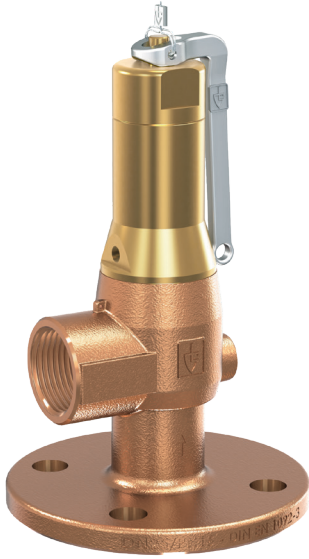

Gunmetal Safety Valve

Features

- Flanged Connection
- Body Gunmetal
- Suitable for Gases and Liquids
- Fitted with Diaphragm to Protect Spring Housing
- Set Range 0.5 to 16 Bar
- WRAS Approved
- ISO 4126-1, PED 2014/68/EU
- Marine Approvals - GL, DNV
- ATEX Approval Available at Extra Cost
- 5 Year Warranty
- Test Certificate to EN10204-3.1 Available on Request

Typical Applications

- Pressure Vessels
- Mechanical engineering
- Pump protection
- Pressure booster systems water/air-side
- Cooling/Chilling Systems
- Steam and industrial boiler systems

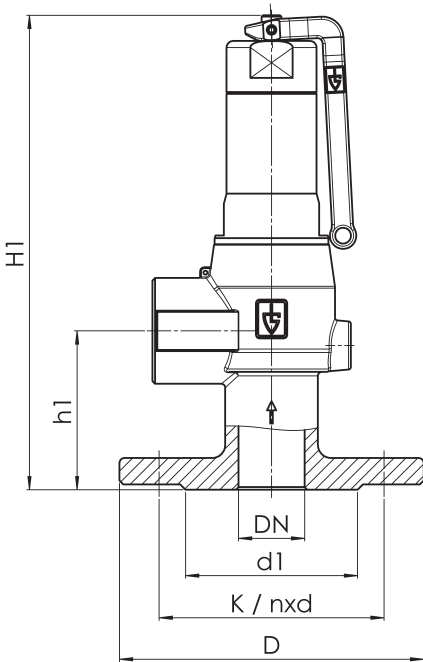

DN	1"	1¼"	1½"	2"	2½"
H1 DIN / ANSI	180 / 180	216 / 216	265 / 265	312 / 312	371 / 371
h1 DIN / ANSI	60 / 60	66 / 66	73 / 73	83 / 83	96 / 96
D DIN / ANSI	115 / 110	140 / 115	150 / 125	165 / 150	185 / 180
d1 DIN / ANSI	65 / 50.8	76 / 63.5	84 / 73	99 / 92.1	118 / 104.8
K / nxd (DIN)	85 / 4x14	100 / 4x18	110 / 4x18	125 / 4x18	145 / 4x18
K / nxd (ANSI)	79.4 / 4x15.9	88.9 / 4x15.9	98.4 / 4x15.9	120.7 / 4x19.1	139.7 / 4x19.1
kg FLDIN / FLANSI	2.0 / 1.9	3.4 / 2.9	4.1 / 3.5	8.4 / 7.9	12.0 / 11.8

Technical Data

Max Pressure	16 Bar
Working Temperature	EPDM Diaphragm -50°C to +195°C

Dimensions in mm

This data sheet is designed as a guide and should not be regarded as wholly accurate in every detail. We reserve the right to amend the specification of any product without notice.

Part Name	Materials
Body	Gunmetal
Housing Cap	Brass / Gunmetal
Spring Housing	Brass / Gunmetal
Lifting Lever	Stainless Steel CF8M
Spring	Stainless Steel 302
Seat-Seal	PTFE
Diaphragm	EPDM

Nm³/h - Air
 Kg/h - Steam
 M³/h - Water
 Kw - Heating Water

Discharge Capacities

DN Bar	1"				1 1/4"				1 1/2"			
	Nm ³ /h	kg/h	m ³ /h	kW	Nm ³ /h	kg/h	m ³ /h	kW	Nm ³ /h	kg/h	m ³ /h	kW
0.5	143	117	4.3	72	234	191	7.0	118	338	276	10.5	170
1	207	165	5.8	101	338	269	9.5	164	491	392	14.3	239
2	340	268	8.2	160	556	437	13.5	262	816	642	20.2	385
3	468	365	10.1	215	764	595	16.5	352	1128	879	24.8	520
4	592	458	11.7	267	966	748	19.1	436	1430	1107	28.7	646
5	712	549	13.1	316	1163	896	21.3	517	1721	1326	32.1	765
6	833	639	14.3	365	1359	1043	23.4	595	2013	1544	35.1	882
7	953	729	15.5	412	1556	1190	25.2	673	2304	1762	37.9	996
8	1074	819	16.5	459	1753	1337	27.0	749	2595	1979	40.6	1109
9	1194	908	17.5	505	1950	1483	28.6	825	2887	2196	43.0	1221
10	1315	998	18.5	550	2147	1629	30.2	899	3178	2412	45.4	1331
11	1435	1088	19.4	595	2343	1776	31.7	972	3469	2629	47.6	1439
12	1556	1177	20.2	640	2540	1922	33.1	1045	3761	2845	49.7	1547
13	1676	1266	21.1	684	2737	2068	34.4	1116	4052	3061	51.7	1652
14	1797	1356	21.9	727	2934	2214	35.7	1187	4343	3278	53.7	1758
15	1917	1446	22.6	770	3130	2361	37.0	1257	4635	3495	55.6	1862
16	2038	1535	23.4	813	3327	2507	38.2	1327	4926	3711	57.4	1964

DN Bar	2"				2 1/2"			
	Nm ³ /h	kg/h	m ³ /h	kW	Nm ³ /h	kg/h	m ³ /h	kW
0.5	571	466	17.7	288	864	706	26.8	436
1	831	662	24.1	404	1258	1003	36.5	612
2	1379	1085	34.2	650	2089	1643	51.8	985
3	1907	1486	41.9	878	2888	2251	63.5	1330
4	2417	1872	48.4	1092	3661	2835	73.4	1654
5	2909	2241	54.2	1293	4407	3395	82.1	1958
6	3402	2609	59.4	1490	5153	3953	89.9	2257
7	3894	2977	64.1	1684	5899	4510	97.1	2551
8	4386	3344	68.6	1875	6644	5066	103.9	2840
9	4879	3711	72.7	2063	7390	5621	110.2	3125
10	5371	4077	76.7	2249	8136	6175	116.1	3407
11	5863	4443	80.4	2433	8882	6730	121.8	3685
12	6356	4809	84.0	2614	9627	7284	127.2	3959
13	6848	5174	87.4	2793	10373	7837	132.4	4230
14	7340	5541	90.7	2970	11119	8393	137.4	4500
15	7833	5907	93.9	3146	11865	8948	142.3	4766
16	8325	6272	97.0	3319	12611	9501	146.9	5028

Seat-Seal/Diaphragm Options

Option	Materials	Type	Working Temp.
PTFE/EPDM	Polytetrafluorethylen/Ethylen-Propylene-Diene (Standard)	Flat seal and moulded diaphragm	-50°C to +195°C
EPDM/EPDM	Ethylen-Propylene-Diene/Ethylen-Propylene-Diene	Flat seal and moulded diaphragm	-50°C to +150°C
PTFE/FKM	Polytetrafluorethylen/Fluorcarbon	Flat seal and moulded diaphragm	-30°C to +200°C
FKM/FKM	Fluorcarbon/Fluorcarbon	Elastomere seals and moulded diaphragm	-20°C to +200°C

Dimensions in mm

This data sheet is designed as a guide and should not be regarded as wholly accurate in every detail. We reserve the right to amend the specification of any product without notice.



Gunmetal High Discharge Safety Valve

Features

- Screwed BSP Parallel (ISO 228)
- Body Gunmetal
- Suitable for Gases and Liquids
- Fitted with Diaphragm to Protect Spring Housing
- Set Range 0.5 to 16 Bar
- WRAS Approved
- ISO 4126-1, PED 2014/68/EU
- Marine Approvals - GL, DNV
- ATEX Approval Available at Extra Cost
- 5 Year Warranty
- Test Certificate to EN10204-3.1 Available on Request
- High Capacity Discharge

Typical Applications

- Pressure Vessels
- Mechanical engineering
- Pump protection
- Pressure booster systems water/air-side
- Cooling/Chilling Systems
- Steam and industrial boiler systems

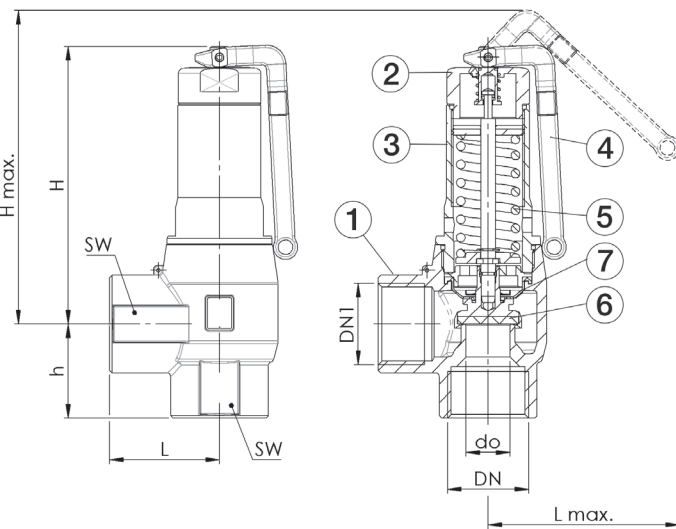

DN	1/2"	3/4"	1"	1 1/4"	1 1/2"	2"
DN1	3/4"	1"	1 1/4"	1 1/2"	2"	2 1/2"
L	36	43	47	58	68	80
Lmax	63	78	100	140	150	155
H	90	115	146	192	229	275
Hmax	102	133	148	210	252	298
h	30	35	37	45	55	65
SW1	27	34	41	55	65	80
SW2	34	41	50	60	70	90
do	13	18	23	30	39	48
kg	0.5	0.9	1.6	3.3	5.8	8.9

N.	Part Name	Materials
1	Body	Gunmetal
2	Housing Cap	Brass / Gunmetal
3	Spring Housing	Brass / Gunmetal
4	Lifting Lever	Stainless Steel CF8M
5	Spring	Stainless Steel 302
6	Seat-Seal	PTFE
7	Diaphragm	EPDM

Technical Data

Max Pressure	16 Bar
Working Temperature	EPDM Diaphragm -50°C to +195°C

Dimensions in mm

This data sheet is designed as a guide and should not be regarded as wholly accurate in every detail. We reserve the right to amend the specification of any product without notice.

Nm³/h - Air
 Kg/h - Steam
 M³/h - Water
 Kw - Heating Water

Discharge Capacities

DN Bar	1/2"				3/4"				1"			
	Nm ³ /h	kg/h	m ³ /h	kW	Nm ³ /h	kg/h	m ³ /h	kW	Nm ³ /h	kg/h	m ³ /h	kW
0.5	76	62	2.3	38	143	117	4.3	72	234	191	7.0	118
1	110	88	3.2	54	207	165	5.8	101	338	269	9.5	164
2	180	142	4.5	85	340	268	8.2	160	556	437	13.5	262
3	248	193	5.5	114	468	365	10.1	215	764	595	16.5	352
4	312	242	6.4	141	592	458	11.7	267	966	748	19.1	436
5	376	290	7.1	167	712	549	13.1	316	1163	896	21.3	517
6	440	337	7.8	193	833	639	14.3	365	1359	1043	23.4	595
7	503	385	8.4	218	953	729	15.5	412	1556	1190	25.2	673
8	567	432	9.0	242	1074	819	16.5	459	1753	1337	27.0	749
9	631	480	9.6	267	1194	908	17.5	505	1950	1483	28.6	825
10	694	527	10.1	291	1315	998	18.5	550	2147	1629	30.2	899
11	758	574	10.6	315	1435	1088	19.4	595	2343	1776	31.7	972
12	822	622	11.1	338	1556	1177	20.2	640	2540	1922	33.1	1045
13	885	669	11.5	361	1676	1266	21.1	684	2737	2068	34.4	1116
14	949	716	11.9	384	1797	1356	21.9	727	2934	2214	35.7	1187
15	1013	764	12.4	407	1917	1446	22.6	770	3130	2361	37.0	1257
16	1076	811	12.8	429	2038	1535	23.4	813	3327	2507	38.2	1327

DN Bar	1 1/4"				1 1/2"				2"			
	Nm ³ /h	kg/h	m ³ /h	kW	Nm ³ /h	kg/h	m ³ /h	kW	Nm ³ /h	kg/h	m ³ /h	kW
0.5	338	276	10.5	170	571	466	17.7	288	864	706	26.8	436
1	491	392	14.3	239	831	662	24.1	404	1258	1003	36.5	612
2	816	642	20.2	385	1379	1085	34.2	650	2089	1643	51.8	985
3	1128	879	24.8	520	1907	1486	41.9	878	2888	2251	63.5	1330
4	1430	1107	28.7	646	2417	1872	48.4	1092	3661	2835	73.4	1654
5	1721	1326	32.1	765	2909	2241	54.2	1293	4407	3395	82.1	1958
6	2013	1544	35.1	882	3402	2609	59.4	1490	5153	3953	89.9	2257
7	2304	1762	37.9	996	3894	2977	64.1	1684	5899	4510	97.1	2551
8	2595	1979	40.6	1109	4386	3344	68.6	1875	6644	5066	103.9	2840
9	2887	2196	43.0	1221	4879	3711	72.7	2063	7390	5621	110.2	3125
10	3178	2412	45.4	1331	5371	4077	76.7	2249	8136	6175	116.1	3407
11	3469	2629	47.6	1439	5863	4443	80.4	2433	8882	6730	121.8	3685
12	3761	2845	49.7	1547	6356	4809	84.0	2614	9627	7284	127.2	3959
13	4052	3061	51.7	1652	6848	5174	87.4	2793	10373	7837	132.4	4230
14	4343	3278	53.7	1758	7340	5541	90.7	2970	11119	8393	137.4	4500
15	4635	3495	55.6	1862	7833	5907	93.9	3146	11865	8948	142.3	4766
16	4926	3711	57.4	1964	8325	6272	97.0	3319	12611	9501	146.9	5028

Seat-Seal/Diaphragm Options

Option	Materials	Type	Working Temp.
PTFE/EPDM	Polytetrafluorethylen/Ethylen-Propylene-Diene (Standard)	Flat seal and moulded diaphragm	-50°C to +195°C
EPDM/EPDM	Ethylen-Propylene-Diene/Ethylen-Propylene-Diene	Flat seal and moulded diaphragm	-50°C to +150°C
PTFE/FKM	Polytetrafluorethylen/Fluorcarbon	Flat seal and moulded diaphragm	-30°C to +200°C
FKM/FKM	Fluorcarbon/Fluorcarbon	Elastomere seals and moulded diaphragm	-20°C to +200°C

Dimensions in mm

This data sheet is designed as a guide and should not be regarded as wholly accurate in every detail. We reserve the right to amend the specification of any product without notice.

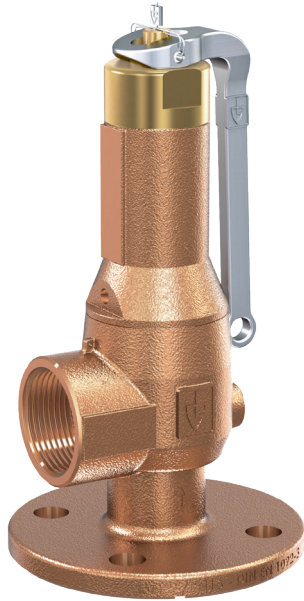

Gunmetal High Discharge Safety Valve

Features

- Flange Connection
- Body Gunmetal
- Suitable for Gases and Liquids
- Fitted with Diaphragm to Protect Spring Housing
- Set Range 0.5 to 16 Bar
- WRAS Approved
- ISO 4126-1, PED 2014/68/EU
- Marine Approvals - GL, DNV
- ATEX Approval Available at Extra Cost
- 5 Year Warranty
- Test Certificate to EN10204-3.1 Available on Request
- High Capacity Discharge

Typical Applications

- Pressure Vessels
- Mechanical engineering
- Pump protection
- Pressure booster systems water/air-side
- Cooling/Chilling Systems
- Steam and industrial boiler systems

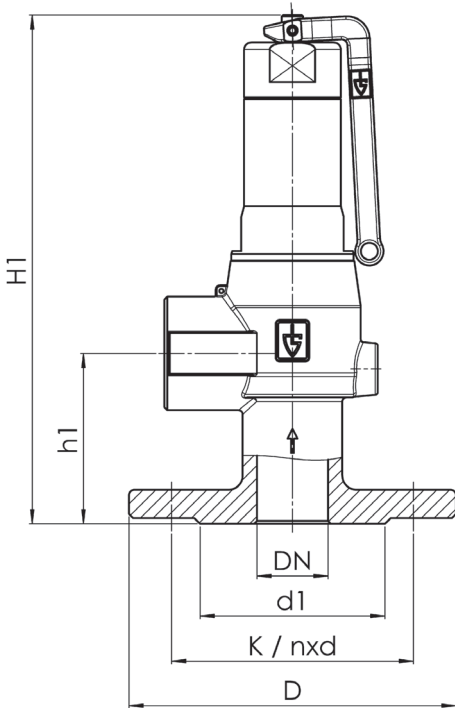

DN	1"	1¼"	1½"	2"
H1 DIN / ANSI	206 / 206	258 / 258	302 / 302	358 / 358
h1 DIN / ANSI	60 / 60	66 / 66	73 / 73	83 / 83
D DIN / ANSI	115 / 110	140 / 115	150 / 125	165 / 150
d1 DIN / ANSI	65 / 50.8	76 / 63.5	84 / 73	99 / 92.1
K / nxd (DIN)	85 / 4x14	100 / 4x18	110 / 4x18	125 / 4x18
K / nxd (ANSI)	79.4 / 4x15.9	88.9 / 4x15.9	98.4 / 4x15.9	120.7 / 4x19.1
kg FLDIN / FLANSI	2.6 / 2.4	4.8 / 4.3	7.5 / 6.9	11.3 / 10.8

Part Name	Materials
Body	Gunmetal
Housing Cap	Brass / Gunmetal
Spring Housing	Brass / Gunmetal
Lifting Lever	Stainless Steel CF8M
Spring	Stainless Steel 302
Seat-Seal	PTFE
Diaphragm	EPDM

Technical Data

Max Pressure	16 Bar
Working Temperature	EPDM Diaphragm -50°C to +195°C

Dimensions in mm

This data sheet is designed as a guide and should not be regarded as wholly accurate in every detail. We reserve the right to amend the specification of any product without notice.

Nm³/h - Air
 Kg/h - Steam
 M³/h - Water
 Kw - Heating Water

Discharge Capacities

DN Bar	1"				1 1/4"			
	Nm ³ /h	kg/h	m ³ /h	kW	Nm ³ /h	kg/h	m ³ /h	kW
0.5	234	191	7.0	118	338	276	10.5	170
1	338	269	9.5	164	491	392	14.3	239
2	556	437	13.5	262	816	642	20.2	385
3	764	595	16.5	352	1128	879	24.8	520
4	966	748	19.1	436	1430	1107	28.7	646
5	1163	896	21.3	517	1721	1326	32.1	765
6	1359	1043	23.4	595	2013	1544	35.1	882
7	1556	1190	25.2	673	2304	1762	37.9	996
8	1753	1337	27.0	749	2595	1979	40.6	1109
9	1950	1483	28.6	825	2887	2196	43.0	1221
10	2147	1629	30.2	899	3178	2412	45.4	1331
11	2343	1776	31.7	972	3469	2629	47.6	1439
12	2540	1922	33.1	1045	3761	2845	49.7	1547
13	2737	2068	34.4	1116	4052	3061	51.7	1652
14	2934	2214	35.7	1187	4343	3278	53.7	1758
15	3130	2361	37.0	1257	4635	3495	55.6	1862
16	3327	2507	38.2	1327	4926	3711	57.4	1964

DN Bar	1 1/2"				2"			
	Nm ³ /h	kg/h	m ³ /h	kW	Nm ³ /h	kg/h	m ³ /h	kW
0.5	571	466	17.7	288	864	706	26.8	436
1	831	662	24.1	404	1258	1003	36.5	612
2	1379	1085	34.2	650	2089	1643	51.8	985
3	1907	1486	41.9	878	2888	2251	63.5	1330
4	2417	1872	48.4	1092	3661	2835	73.4	1654
5	2909	2241	54.2	1293	4407	3395	82.1	1958
6	3402	2609	59.4	1490	5153	3953	89.9	2257
7	3894	2977	64.1	1684	5899	4510	97.1	2551
8	4386	3344	68.6	1875	6644	5066	103.9	2840
9	4879	3711	72.7	2063	7390	5621	110.2	3125
10	5371	4077	76.7	2249	8136	6175	116.1	3407
11	5863	4443	80.4	2433	8882	6730	121.8	3685
12	6356	4809	84.0	2614	9627	7284	127.2	3959
13	6848	5174	87.4	2793	10373	7837	132.4	4230
14	7340	5541	90.7	2970	11119	8393	137.4	4500
15	7833	5907	93.9	3146	11865	8948	142.3	4766
16	8325	6272	97.0	3319	12611	9501	146.9	5028

Seat-Seal/Diaphragm Options

Option	Materials	Type	Working Temp.
PTFE/EPDM	Polytetrafluorethylen/Ethylen-Propylene-Diene (Standard)	Flat seal and moulded diaphragm	-50°C to +195°C
EPDM/EPDM	Ethylen-Propylene-Diene/Ethylen-Propylene-Diene	Flat seal and moulded diaphragm	-50°C to +150°C
PTFE/FKM	Polytetrafluorethylen/Fluorcarbon	Flat seal and moulded diaphragm	-30°C to +200°C
FKM/FKM	Fluorcarbon/Fluorcarbon	Elastomere seals and moulded diaphragm	-20°C to +200°C

Dimensions in mm

This data sheet is designed as a guide and should not be regarded as wholly accurate in every detail. We reserve the right to amend the specification of any product without notice.

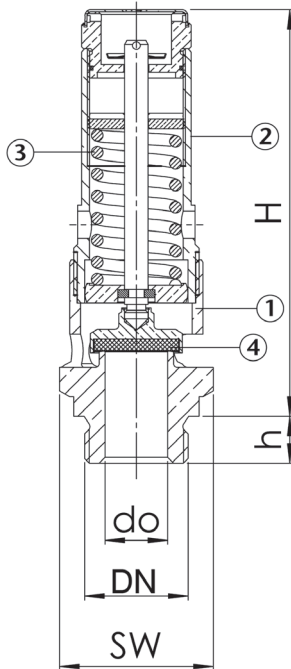

Brass Atmospheric Discharge Safety Valve

Features

- Male BSP Parallel (ISO 228)
- Body Brass
- Suitable for neutral gases and air
- Set pressure: 0.2 to 50 bar
- ISO 4126-1, PED 2014/68/EU
- Marine Approvals - GL, LR EMEA, BV, ABS, DNV, RS
- ATEX Approval Available at Extra Cost
- 24 Month Warranty
- Test Certificate to EN10204-3.1 Available on Request
- Standard Capacity Discharge

Typical Applications

- Compressors
- Pressure booster plants air-side
- Paint spray shops
- Pneumatic control units
- Transport- and railway applications

Safety valves are set and sealed at the factory.

DN	1/4"	3/8"	1/2"	3/4"	1"			
H	60	65	78	66	79	94	104	111
h	10	10	10	12	12	12	12	14
SW	19	24	24	27	27	34	34	41
do	7,5	10	10	11	11	16	16	20
kg	0,1	0,14	0,16	0,17	0,19	0,35	0,4	0,6

Technical Data

Max Pressure	50 Bar
Working Temperature	PTFE Seal -60°C to +225°C

N.	Part Name	Materials
1	Inlet body	Brass CW617N
2	Outlet body	Brass CW617N
3	Internal parts	Brass CW617N
4	Spring	Stainless steel 1.4568

Dimensions in mm

This data sheet is designed as a guide and should not be regarded as wholly accurate in every detail. We reserve the right to amend the specification of any product without notice.

Discharge Capacities

Blowing-off rates at 10% above set pressure					
DN Bar	1/4"	3/8"	1/2" Air [Nm ³ /h]	3/4"	1"
0,2	20	35	46	100	133
0,3	25	45	54	119	144
0,4	29	52	67	137	167
0,5	32	58	74	158	185
0,6	35	64	82	172	211
0,7	37	70	87	187	235
0,8	41	74	95	200	260
0,9	43	80	101	213	282
1	46	85	107	227	305
1,5	60	108	137	286	408
2	73	132	166	346	506
3	100	182	222	465	699
4	125	228	279	584	889
5	151	274	336	703	1070
6	176	321	393	821	1251
7	201	367	450	940	1432
8	227	414	507	1059	1613
9	252	460	564	1178	1794
10	278	507	621	1297	1975
11	303	553	678	1416	2156
12	329	599	735	1535	2337
13	354	646	791	1654	2518
14	380	692	848	1773	2700
15	405	739	905	1891	2881
16	431	785	962	2010	3062
17	456	832	1019	2129	3243
18	482	878	1076	2248	3424
19	507	925	1133	2367	3605
20	533	971	1190	2486	3786
21	558	1017	1247	2605	3967
22	584	1064	1304	2724	4148
23	609	1110	1361	2843	4329
24	635	1157	1417	2961	4510
25	660	1203	1474	3080	4691
26	685	1250	1531	3199	4872
27	711	1296	1588	3318	5053
28	736	1342	1645	3437	5234
29	762	1389	1702	3556	5415
30	787	1435	1759	3675	5597
31	813	1482	1816	3794	5778
32	838	1528	1873	3913	5959
33	864	1575	1930	4031	6140
34	889	1621	1986	4150	6321
35	915	1667	2043	4269	6502
36	940	1714	2100	4388	6683
37	966	1760	2157	4507	6864
38	991	1807	2214	4626	7045
39	1017	1853	2271	4745	7226
40	1042	1900	2328	4864	7407
41	1068	1946	2385	4983	7588
42	1093	1993	2442	5101	7769
43	1119	2039	2499	5220	7950
44	1144	2085	2556	5339	8131
45	1170	2132	2612	5458	8313
46	1195	2178	2669	5577	8494
47	1220	2225	2726	5696	8675
48	1246	2271	2783	5815	8856
49	1271	2318	2840	5934	9037
50	1297	2364	2897	6053	9218

Seat-Seal/Diaphragm Options

Option	Materials	Type	Working Temp.
FKM	Fluorocarbon	Elastomere flat seal 0,2 – 25 bar	-20°C to +200°C
PTFE	Polytetrafluoroethylene	Flat seal 25,1 – 50 bar	-60°C to +225°C
Against surcharge			
PTFE	Polytetrafluoroethylene	Flat seal 0,2 – 25 bar	-60°C to +225°C

Dimensions in mm

This data sheet is designed as a guide and should not be regarded as wholly accurate in every detail. We reserve the right to amend the specification of any product without notice.

Stainless Steel Safety Valve

Features

- Screwed BSP Parallel (ISO 228)
- Body Stainless Steel
- Suitable for Gases, Liquids & Steam
- Set pressure: 0.5 to 70 bar
- ISO 4126-1, PED 2014/68/EU
- Marine Approvals - GL, LR EMEA, ABS, DNV, BV, RS
- ATEX Approval Available at Extra Cost
- 24 Month Warranty
- Test Certificate to EN10204-3.1 Available on Request

Typical Applications

- Chemical plants, biogas plants
- Process equipment construction and medical technology (sterilizers, autoclaves)
- Secondary areas in the food-, beverage-, pharmaceutical- and cosmetics-industries

Safety valves are set and sealed at the factory.

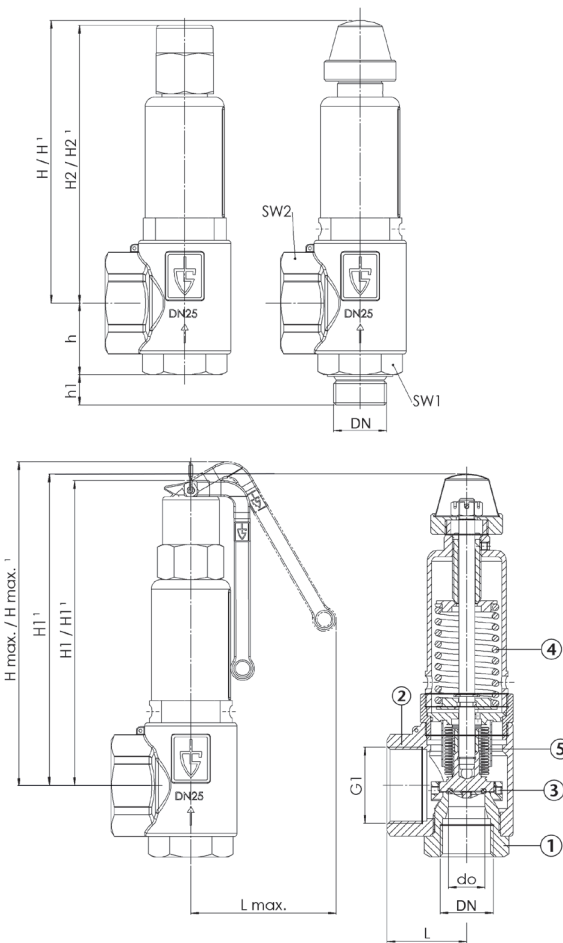

Technical Data	
Max Pressure	70 Bar
Working Temperature	PTFE Seal -60°C to +225°C

DN	1/2"	3/4"	1"	1 1/4"	1 1/2"	2"	2 1/2"	3"	4"
G1	1/2" (15)	1" (25)	1" (25)	3/4" (20)	1 1/4" (32)	1 1/2" (32)	2" (50)	2 1/2" (40)	3" (50)
L	34	40	40	42	43	50	61	61	61
Lmax	65	65	65	91	91	92	92	92	92
H / H1	79 / 79	77 / 77	131 / 131	137 / 137	138 / 152	178 / 196	241 / 263	241 / 263	241 / 263
H2 / H21	93 / 93	91 / 91	149 / 149	154 / 154	158 / 174	192 / 210	264 / 286	264 / 286	264 / 286
h	28	30	30	31	39	45	55	69	74
h1	15	15	15	16	16	18	20	23	25
SW1	30	30	30	36	36	46	55	55	70
SW2	-	40	40	32	50	58	70	70	70
do	15,8	15,8	15,8	15,8	18	23	30,3	30,3	30,3
kg	0,4	0,4	0,8	1,0	1,0	1,8	4,0	4,0	4,0
bar	0,5 ² -25	0,5 ² -25	25,1-70	0,5 ² -70	0,5-70	0,5-70	0,5-70	0,5-70	0,5-70

¹Dimension for the version with bellows
²Version with bellows only available from 1 bar

N.	Part Name	Materials
1	Inlet body	Stainless steel 1.4404
2	Outlet body	Stainless steel 1.4408
3	Internal parts	Stainless steel 1.4404
4	Spring	Stainless steel 1.4310
4	Bellows (optional)	Stainless steel 1.4571

Discharge Capacities

Kv values at 1 bar overpressure											
DN	1/2"				3/4"						
			Bellows		do = 15,8			do = 18			
Bar	Air Nm ³ /h	Steam kg/h	Water m ³ /h	without Water m ³ /h	with Water m ³ /h	Air Nm ³ /h	Steam kg/h	Water m ³ /h	Air Nm ³ /h	Steam kg/h	Water m ³ /h
0,5	56**	42**	2,3**	1,9**	64**	48**	2,9**	127	127	96	5,4
1	87	69	3,1	2,5	120	96	4,0	189	189	151	7,3
1,5	113	90	3,8	3,1	166	132	4,9	252	252	200	9,0
2	141	111	4,4	3,6	205	161	5,6	316	316	249	10,4
2,5	165	129	5,0	4,0	250	196	6,3	383	383	300	11,6
3	189	148	5,4	4,4	298	233	6,9	447	447	349	12,7
3,5	214	166	5,9	4,7	336	262	7,4	504	504	392	13,7
4	238	184	6,3	5,0	375	291	8,0	561	561	435	14,7
4,5	262	203	6,7	5,3	413	319	8,4	618	618	478	15,6
5	286	221	7,0	5,6	451	348	8,9	675	675	521	16,4
5,5	310	239	7,4	5,9	489	377	9,3	732	732	564	17,2
6	335	257	7,7	6,2	527	406	9,7	790	790	608	18,0
6,5	359	275	8,0	6,4	565	434	10,1	847	847	650	18,7
7	383	293	8,3	6,6	604	462	10,5	904	904	692	19,4
7,5	407	311	8,6	6,9	642	491	10,9	961	961	735	20,1
8	431	329	8,9	7,1	680	519	11,3	1018	1018	777	20,8
8,5	456	347	9,2	7,3	718	547	11,6	1075	1075	820	21,4
9	480	365	9,4	7,5	756	576	11,9	1132	1132	862	22,0
9,5	504	383	9,7	7,7	794	604	12,3	1190	1190	905	22,6
10	528	401	9,9	7,9	833	632	12,6	1247	1247	947	23,2
11	577	437	10,4	8,3	909	688	13,2	1361	1361	1031	24,3
12	625	472	10,9	8,7	985	744	13,8	1475	1475	1115	25,4
13	674	508	11,3	9,1	1061	801	14,3	1590	1590	1199	26,5
14	722	544	11,8	9,4	1138	857	14,9	1704	1704	1284	27,5
15	770	580	12,2	9,7	1214	914	15,4	1818	1818	1368	28,4
16	819	616	12,6	10,1	1290	970	15,9	1932	1932	1453	29,4
17	867	650	13,0	10,4	1367	1025	16,4	2047	2047	1535	30,3
18	916	686	13,3	10,7	1443	1081	16,9	2161	2161	1619	31,1
19	964	721	13,7	11,0	1519	1137	17,3	2275	2275	1703	32,0
20	1013	757	14,0	11,2	1596	1193	17,8	2390	2390	1787	32,8
21	1061	793	14,4	11,5	1672	1250	18,2	2504	2504	1872	33,6
22	1109	829	14,7	11,8	1748	1306	18,7	2618	2618	1956	34,4
23	1158	865	15,1	12,1	1825	1363	19,1	2732	2732	2040	35,2
24	1206	900	15,4	12,3	1901	1419	19,5	2847	2847	2125	35,9
25	1255	936	15,7	12,6	1977	1475	19,9	2961	2961	2209	36,7
26	1303	972*	16,0	12,8	2054	1532	20,3	3075	3075	2294*	37,4
27	1352	1008*	16,3	13,1	2130	1589	20,7	3190	3190	2379*	38,1
28	1400	1044*	16,6	13,3	2206	1646	21,1	3304	3304	2465*	38,8
29	1449	1081*	16,9	13,5	2283	1703	21,4	3418	3418	2550*	39,5
30	1497	1114*	17,2	13,8	2359	1755	21,8	3532	3532	2628*	40,2
32	1594	1186*	17,8	14,2	2511	1869	22,5	3761	3761	2799*	41,5
34	1691	1258*	18,3	14,7	2664	1982	23,2	3990	3990	2969*	42,8
36	1788	1330*	18,8	15,1	2817	2096	23,9	4218	4218	3139*	44,0
38	1884	1402*	19,4	15,5	2969	2209	24,5	4447	4447	3309*	45,2
40	1981	1474*	19,9	15,9	3122	2323	25,2	4675	4675	3479*	46,4
42	2078	1547*	20,4	16,3	3275	2437	25,8	4904	4904	3650*	47,6
44	2175	1619*	20,8	16,7	3427	2551	26,4	5132	5132	3821*	48,7
46	2272	1692*	21,3	17,0	3580	2666	27,0	5361	5361	3992*	49,8
48	2369	1764*	21,8	17,4	3732	2780	27,6	5589	5589	4163*	50,8
50	2466	1837*	22,2	17,8	3885	2895	28,1	5818	5818	4335*	51,9
52	2562	1910*	22,7	18,1	4038	3009	28,7	6047	6047	4506*	52,9
54	2659	1984*	23,1	18,5	4190	3126	29,2	6275	6275	4681*	53,9
56	2756	2061*	23,5	18,8	4343	3248	29,8	6504	6504	4868*	54,9
58	2853	2136*	23,9	19,1	4496	3366	30,3	6732	6732	5040*	55,9
60	2950	2209*	24,3	19,5	4648	3481	30,8	6961	6961	5213*	56,8
62	3047	2282*	24,7	19,8	4801	3596	31,3	7189	7189	5385*	57,8
64	3144	2355*	25,1	20,1	4954	3711	31,8	7418	7418	5558*	58,7
66	3240	2428*	25,5	20,4	5106	3827	32,3	7647	7647	5730*	59,6
68	3337	2502*	25,9	20,7	5259	3943	32,8	7875	7875	5905*	60,5
70	3434	2578*	26,3	21,0	5411	4062	33,3	8104	8104	6082*	61,4

*) only possible with metal-to-metal sealing

**) Version with bellows only available from 1 bar

Dimensions in mm

This data sheet is designed as a guide and should not be regarded as wholly accurate in every detail. We reserve the right to amend the specification of any product without notice.

Discharge Capacities

Kv values at 1 bar overpressure							
DN Bar	1"			1 1/4"			
	Air Nm ³ /h	Steam kg/h	Water m ³ /h	Air Nm ³ /h	Steam kg/h	Water m ³ /h	
0,5	199	150	8,8	353	266	15,4	
1	291	232	12,0	515	411	20,8	
1,5	390	309	14,7	683	542	25,5	
2	489	385	16,9	832	656	29,4	
2,5	583	457	18,9	1012	793	32,9	
3	681	532	20,8	1182	924	36,0	
3,5	768	597	22,4	1333	1036	38,9	
4	855	663	24,0	1484	1151	41,6	
4,5	942	729	25,4	1635	1265	44,1	
5	1029	794	26,8	1786	1378	46,5	
5,5	1116	860	28,1	1937	1492	48,8	
6	1203	926	29,3	2088	1607	50,9	
6,5	1290	990	30,5	2239	1719	53,0	
7	1377	1054	31,7	2390	1830	55,0	
7,5	1464	1119	32,8	2542	1943	56,9	
8	1552	1184	33,9	2693	2056	58,8	
8,5	1639	1249	34,9	2844	2168	60,6	
9	1726	1314	35,9	2995	2281	62,4	
9,5	1813	1379	36,9	3146	2392	64,1	
10	1900	1443	37,9	3297	2504	65,8	
11	2074	1571	39,7	3599	2727	69,0	
12	2248	1699	41,5	3902	2948	72,0	
13	2422	1827	43,2	4204	3172	75,0	
14	2596	1957	44,8	4506	3396	77,8	
15	2771	2085	46,4	4808	3618	80,5	
16	2945	2214	47,9	5111	3842	83,2	
17	3119	2339	49,4	5413	4059	85,7	
18	3293	2467	50,8	5715	4281	88,2	
19	3467	2594	52,2	6017	4503	90,6	
20	3641	2723	53,6	6320	4726	93,0	
21	3816	2852	54,9	6622	4950	95,3	
22	3990	2981	56,2	6924	5173	97,5	
23	4164	3109	57,5	7226	5396	99,7	
24	4338	3238	58,7	7529	5619	101,9	
25	4512	3366	59,9	7831	5842	104,0	
26	4686	3496*	61,1	8133	6067*	106,0	
27	4860	3626*	62,3	8435	6293*	108,0	
28	5035	3756*	63,4	8738	6518*	110,0	
29	5209	3886*	64,5	9040	6744*	112,0	
30	5383	4005*	65,6	9342	6951*	113,9	
32	5731	4265*	67,8	9947	7401*	117,6	
34	6080	4524*	69,9	10551	7851*	121,2	
36	6428	4783*	71,9	11156	8301*	124,8	
38	6776	5042*	73,9	11760	8751*	128,2	
40	7124	5301*	75,8	12365	9200*	131,5	
42	7473	5562*	77,6	12969	9653*	134,8	
44	7821	5823*	79,5	13574	10105*	137,9	
46	8169	6083*	81,3	14178	10558*	141,0	
48	8518	6344*	83,0	14783	11011*	144,1	
50	8866	6606*	84,7	15387	11464*	147,0	
52	9214	6867*	86,4	15992	11917*	149,9	
54	9563	7134*	88,0	16596	12380*	152,8	
56	9911	7412*	89,7	17200	12864*	155,6	
58	10259	7681*	91,2	17805	13330*	158,4	
60	10608	7943*	92,8	18409	13786*	161,1	
62	10956	8206*	94,3	19014	14242*	163,7	
64	11304	8469*	95,8	19618	14699*	166,3	
66	11652	8732*	97,3	20223	15155*	168,9	
68	12001	8998*	98,8	20827	15616*	171,5	
70	12349	9269*	100,2	21432	16086*	174,0	

*) only possible with metal-to-metal sealing

Dimensions in mm

This data sheet is designed as a guide and should not be regarded as wholly accurate in every detail. We reserve the right to amend the specification of any product without notice.

Seat-Seal/Diaphragm Options

Option	Materials	Type	Working Temp.
NBR	Nitrile rubber	Elastomere moulded seal with metallic support up to 25 bar	-30°C to +130°C
EPDM	Ethylene propylene diene	Elastomere moulded seal with metallic support up to 25 bar	-40°C to +170°C
FKM	Fluorcarbon	Elastomere moulded seal with metallic support up to 25 bar	-20°C to +200°C
PTFE	Polytetrafluoroethylene	Flat seal up to 25 bar	-60°C to +225°C
PTFE+Kohle	Polytetrafluoroethylene + carbon	Flat seal from 25 bar	-60°C to +225°C
Against surcharge			
FFKM	Perfluorinated rubber	Elastomere moulded seal with metallic support up to 25 bar	-10°C to +260°C
MD	Metal-to-metal sealing	Flat seal	-60°C to +400°C

Stainless Steel Safety Valve

Features

- Male BSP Parallel (ISO 228)
- Body Stainless Steel
- Suitable for Gases, Liquids & Steam
- Set pressure: 0.2 to 25 bar
- ISO 4126-1, PED 2014/68/EU
- Marine Approvals - GL, LR EMEA, ABS, DNV, RS
- ATEX Approval Available at Extra Cost
- 24 Month Warranty
- Test Certificate to EN10204-3.1 Available on Request

Typical Applications

- Chemical plants, biogas plants
- Desalination plants
- Process equipment construction and medical technology
- Shipbuilding industry and marine equipment
- Secondary areas in the food-, beverage-, pharmaceutical- and cosmetics-industries

Safety valves are set and sealed at the factory.

DN	3/8"	1/2"	3/4"	1"
L	30	36	43	47
Lmax	72	72	72	72
H	77,5	82	90,5	101
H1	98	107	117	127
h	17	19	20	22
h1	12	15	16	18
SW1	24	27	34	38
SW2	22	26	32	38
do	9	13	15	18
kg	0,3	0,4	0,6	0,8

N.	Part Name	Materials
1	Inlet body	Stainless steel 1.4408
2	Outlet body	Stainless steel 1.4408
3	Internal parts	Stainless steel 1.4401
4	Spring	Stainless steel 1.4310

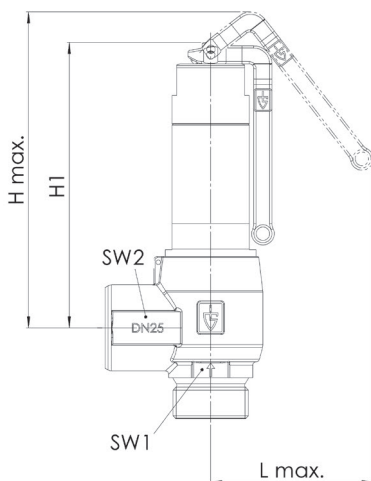
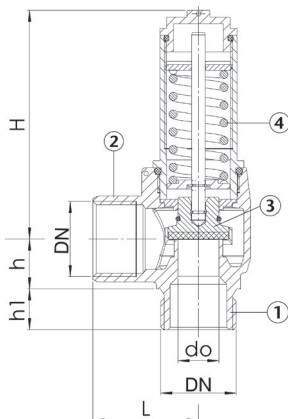

Technical Data

Max Pressure	25 Bar
Working Temperature	PTFE Seal -60°C to +225°C

Dimensions in mm

This data sheet is designed as a guide and should not be regarded as wholly accurate in every detail. We reserve the right to amend the specification of any product without notice.

Discharge Capacities

Kv values at 1 bar overpressure												
DN Bar	3/8"			1/2"			3/4"			1"		
	Air Nm ³ /h	Steam kg/h	Water m ³ /h	Air Nm ³ /h	Steam kg/h	Water m ³ /h	Air Nm ³ /h	Steam kg/h	Water m ³ /h	Air Nm ³ /h	Steam kg/h	Water m ³ /h
0,2	18	14	0,6	41	33	1,3	58	46	1,8	77	61	2,6
0,5	25	20	0,8	62	50	1,9	81	65	2,5	111	89	3,7
0,8	34	27	1,0	82	65	2,3	107	85	3,1	145	115	4,7
1	39	31	1,1	95	75	2,6	124	97	3,4	167	132	5,2
1,5	53	41	1,4	127	99	3,3	169	132	4,2	243	191	6,3
2	65	51	1,6	159	124	3,8	212	165	4,8	310	243	7,3
2,5	80	62	1,8	190	147	4,3	257	200	5,4	370	288	7,7
3	91	71	2,0	217	169	4,7	295	229	5,9	439	341	8,5
3,5	105	81	2,2	250	193	5,1	338	262	6,4	512	396	9,2
4	119	92	2,3	278	214	5,5	383	296	7,0	570	440	9,8
4,5	134	103	2,5	306	236	5,8	429	331	7,4	628	485	10,4
5	146	113	2,7	340	263	6,1	469	362	7,8	687	530	10,9
5,5	159	122	2,8	369	285	6,4	509	392	8,2	745	574	11,5
6	174	135	2,9	398	307	6,7	557	430	8,6	804	620	12,0
6,5	187	144	3,0	442	341	7,0	598	461	8,9	864	666	12,5
7	200	154	3,1	471	364	7,2	638	492	9,7	934	721	12,9
7,5	216	167	3,3	510	393	7,5	678	523	10,1	993	766	13,4
8	246	190	3,4	549	423	7,7	719	555	10,4	1052	812	13,8
8,5	260	200	3,6	580	447	8,0	759	586	10,7	1111	857	14,3
9	274	211	3,7	610	471	8,2	799	617	11,0	1170	903	14,7
9,5	287	222	3,8	641	495	8,4	840	648	11,3	1229	948	15,1
10	301	232	3,9	672	518	8,6	880	679	11,6	1288	994	15,5
11	329	254	4,1	734	566	9,1	961	741	12,2	1406	1085	16,2
12	357	275	4,2	795	613	9,5	1042	803	12,7	1524	1176	16,9
13	384	296	4,4	857	661	9,8	1122	866	13,3	1643	1267	17,6
14	412	318	4,6	918	708	10,2	1203	928	13,8	1761	1358	18,3
15	439	339	4,7	980	756	10,6	1284	990	14,3	1879	1449	18,9
16	467	360	4,9	1042	803	10,9	1364	1052	14,7	1997	1540	19,6
17	495	382	5,0	1103	851	11,3	1445	1115	15,2	2115	1632	20,2
18	522	403	5,2	1165	899	11,6	1526	1177	15,6	2233	1723	20,8
19	550	424	5,3	1226	946	11,9	1606	1239	16,0	2351	1814	21,3
20	577	446	5,5	1288	994	12,2	1687	1301	16,5	2469	1905	21,9
21	605	467	5,6	1350	1041	12,5	1768	1364	16,9	2587	1996	22,4
22	633	488	5,7	1411	1089	12,8	1848	1426	17,3	2705	2087	22,9
23	660	509	5,9	1473	1136	13,1	1929	1488	17,6	2823	2178	23,5
24	688	531	6,0	1534	1184	13,4	2010	1550	18,0	2942	2269	24,0
25	716	552	6,1	1596	1231	13,6	2090	1613	18,4	3060	2360	24,5

Seat-Seal/Diaphragm Options

Option	Materials	Type	Working Temp.
NBR	Nitrile rubber	Elastomere flat seal	-30°C to +130°C
EPDM	Ethylene propylene diene	Elastomere flat seal	-50°C to +150°C
FKM	Fluorcarbon	Elastomere flat seal	-20°C to +200°C
PTFE	Polytetrafluoroethylene	Flat seal from 0,5 bar	-60°C to +225°C

Dimensions in mm

This data sheet is designed as a guide and should not be regarded as wholly accurate in every detail. We reserve the right to amend the specification of any product without notice.



Gunmetal Overflow & Pressure Relief Valves

Features

- Screwed BSP Parallel (ISO 228)
- Body Gunmetal
- Suitable for Gases and Liquids
- Set pressure: 0.2 to 20 bar
- PED 2014/68/EU
- Marine Approvals - GL, LR EMEA, ABS, BV, RS
- ATEX Approval Available at Extra Cost
- 24 Month Warranty
- Test Certificate to EN10204-3.1 Available on Request

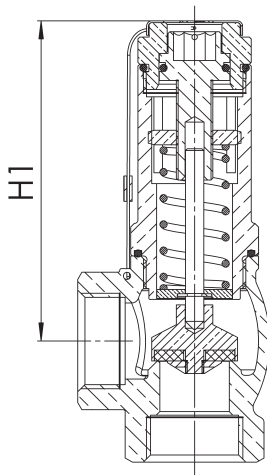
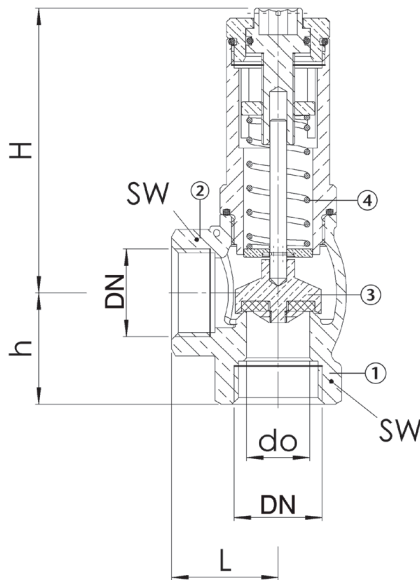

Typical Applications

- Pump protection
- Test rig construction
- Process equipment construction
- Shipbuilding industry and marine equipment
- De-icing technology
- Mechanical engineering
- Industrial applications

DN	3/8"	1/2"	3/4"	1"	1 1/4"	1 1/2"	2"
L	27	30	33	40	45	50	60
H/ H1	60/63	69/72	86/88,5	101/104	118/121	139/141,5	149/152
h	26	30	35	41	45	51	60
SW	24	28	34	41	52	58	70
do	10	13	19	25	30	38	50
kg	0,3	0,4	0,7	1,2	1,9	2,5	3,8

Technical Data

Max Pressure	20 Bar
Working Temperature	PTFE Seal -60°C to +225°C

N.	Part Name	Materials
1	Inlet body	Gunmetal CC499K
2	Outlet body	Gunmetal CC499K
3	Internal parts	Brass CW617N
4	Spring	Stainless steel 1.4310

Dimensions in mm

This data sheet is designed as a guide and should not be regarded as wholly accurate in every detail. We reserve the right to amend the specification of any product without notice.

Discharge Capacities

Kv values at 1 bar overpressure																													
Nominal diameter DN		3/8"				1/2"				3/4"				1"				1 1/4"				1 1/2"				2"			
		Steam [Nm ³ /h]																											
Pressure range bar	Set pressure bar	0,2-0,8	0,5-2,5	2-8	12-20	0,2-0,8	0,5-2,5	2-8	12-20	0,2-0,8	0,5-2,5	2-8	12-20	0,2-0,8	0,5-2,5	2-8	12-20	0,2-0,8	0,5-2,5	2-8	12-20	0,2-0,8	0,5-2,5	2-8	12-20				
		0,2	18				41				138				156				468				726				1172		
0,5	22	65			47	113			156	163			172	295			531	509			757	665			1265	1100			
0,8	25	70			52	120			172	173			191	305			547	541			820	700			1359	1173			
1		74				125				181				313				553				724				1222			
1,5		81				135				200				345				615				798				1345			
2		86	53	40		143	98	73		221	144	126		373	280	218		642	283	194		862	455	311		1451			
2,5		93	60	45		157	104	79		235	161	141		384	302	244		619	301	218		940	510	349		1535	787	663	
3			66	43			111	80			171	156			309	258			297	223			506	387			884	698	
4			79	53			129	79			187	160			339	308			333	244			499	428			876	670	
5			77	66			135	82			186	176			412	322			361	283			579	455			987	740	
6			78	75			132	88			212	200			388	326			441	323			707	518			1145	859	
7			84	81			118	93			225	198			275	298			429	363			740	635			1224	816	
8			89	89			123	96			249	190			254	279			475	402			821	645			1284	916	
9				89				98				193				250				441				707				1015	
10				97				106				192				273				480				770				1002	
11				94				106				189				262				472				833				1090	
12				101	79			105	78			204	183			282	247			406	457			814	570			1179	987
13					84				68				174				189				489				610				1056
14					90				57				162				201				521				650				1125
15					95				54				123				213				552				590				1022
16					94				51				130				180				584				728				1261
17					99				46				110				142				615				768				1140
18					96				32				87				150				576				693				1399
19					101				28				61				105				604				606				1678
20					105				21				32				165				632				634				1537

Seat-Seal/Diaphragm Options

Option	Materials	Type	Working Temp.
NBR	Nitrile rubber (standard)	Elastomere flat seal 0,2 – 12 bar	-30°C to +130°C
FKM	Fluorocarbon	Elastomere flat seal 0,2 – 12 bar	-20°C to +200°C
EPDM	Ethylene propylene diene	Elastomere flat seal 0,2 – 12 bar	-50°C to +150°C
PTFE	Polytetrafluoroethylene	Flat seal 0,5 – 12 bar	-60°C to +225°C
If the seat seal is made of PTFE the O-rings of the body and setting spindle seal are made of FPM.			
Against surcharge			
PTFE	Polytetrafluoroethylene	Flat seal 12 – 20 bar	-60°C to +225°C



Brass Adjustable Pressure Relief Valve

Features

- Screwed BSP Parallel (ISO 228/1)
- Adjustable Range 0.5 to 16 Bar
- Suitable for gases, liquids and steam
- Complies to Directive PED 97/23/EC
- Manual test function
- Suitable for use as a Bypass Valve
- This product should not be used as a safety valve

Pressure / Temperature

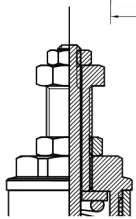
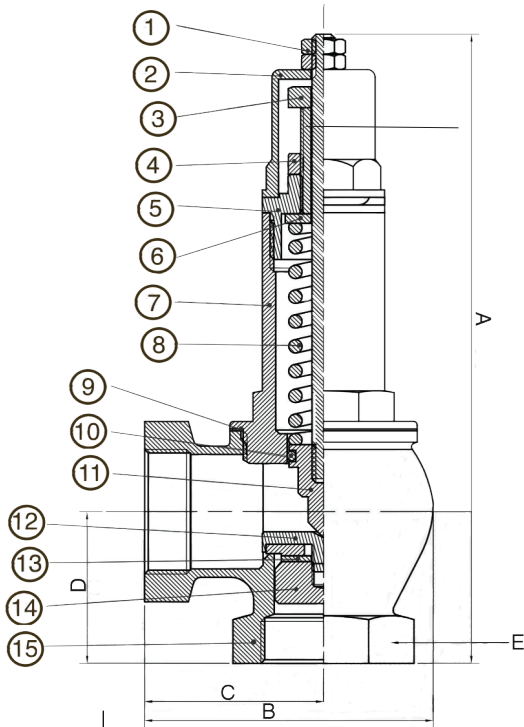
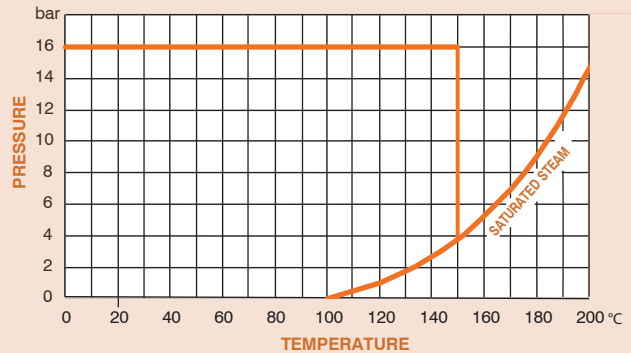

Alternative top on 2 1/2 and 3" valves.

DN	1/2"	3/4"	1"	1 1/4"	1 1/2"	2"	2 1/2"	3"
A	136	158	169	207	230	259	305	315
B	56	64	76	90	100	124	135	145
C	35.5	39.5	47	56	62.5	75	79.5	84.5
D	30	32	40	44	47	60	69	78
E	28	35	41	49	56	71	88	100
Kgs	0.47	0.69	0.97	1.57	2.04	3.18	4.52	5.30

N.	Part Name	Materials
1	Nut and locknut	Brass
2	Housing cap	Brass
3	Regulator	Brass
4	Locknut regulator	Brass
5	Regulator seat	Brass
6	Spring pusher	Brass
7	Bonnet	Brass
8	Spring	Steel
9	Gasket	Pressed fibre
10	O-ring	EPDM rubber
11	Rod	Brass
12	Valve seat	Brass
13	Valve gasket	EPDM rubber
14	Valve nut	Brass
15	Body	Brass

Technical Data

Max Pressure	16 Bar
Adjustable Pressure Range	0.5 - 16 Bar
Working Temperature	0°C to +150°C

Dimensions in mm

This data sheet is designed as a guide and should not be regarded as wholly accurate in every detail. We reserve the right to amend the specification of any product without notice.

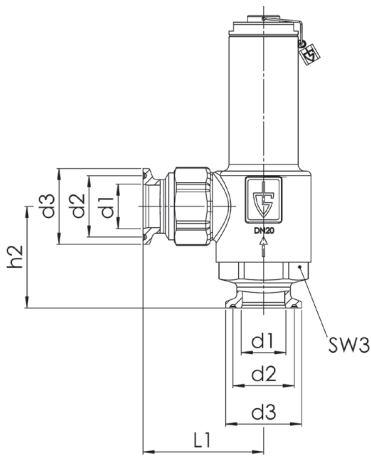
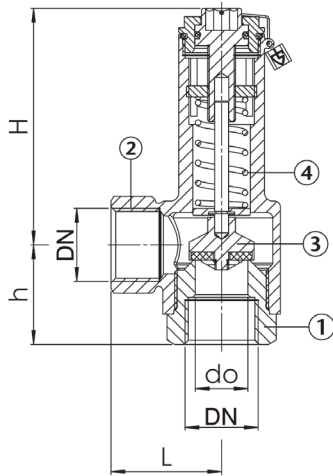

Stainless Steel Overflow & Pressure Relief Valves

Features

- Screwed BSP Parallel (ISO 228)
- Body Stainless Steel
- Suitable for Gases and Liquids
- Set pressure: 0.2 to 20 bar
- PED 2014/68/EU
- Marine Approvals - GL, LR EMEA, ABS, BV, RS
- ATEX Approval Available at Extra Cost
- 24 Month Warranty
- Test Certificate to EN10204-3.1 Available on Request

Typical Applications

- Chemical plants, biogas plants
- Desalination plants
- Mechanical engineering and process equipment construction
- Shipbuilding industry and marine equipment
- Industrial applications
- Secondary areas in the food, beverage, pharmaceutical and cosmetics industries

DN	3/8"	1/2"	3/4"	1"	1 1/4"	1 1/2"	2"
L	30	34	40	46	50	61	67
L1	41	44	54	57	61	75	82
H	60	69	86	101	118	139	149
h	29	33	36	67	52	60	66
h1	42	49	50	67	71	85	91
h2	41	46	46	61	63	76	80
d1	10	16	20	26	32	38	50
d2	27,5	27,5	27,5	43,5	43,5	43,5	56,5
d3	34	34	34	50,5	50,5	50,5	64
SW3	30	30	36	46	55	65	70
do	10	13	19	25	30	38	50
kg	0,3	0,4	0,7	1,2	1,9	2,5	3,8

Technical Data

Max Pressure	20 Bar
Working Temperature	PTFE Seal -60°C to +225°C

N.	Part Name	Materials
1	Inlet body	Stainless steel 1.4404
2	Outlet body	Stainless steel 1.4404 / 1.4408
3	Internal parts	Stainless steel 1.4404
4	Spring	Stainless steel 1.4310

Dimensions in mm

This data sheet is designed as a guide and should not be regarded as wholly accurate in every detail. We reserve the right to amend the specification of any product without notice.

Discharge Capacities

Kv values at 1 bar overpressure																															
DN		3/8"				1/2"				3/4"				1"				1 1/4"				1 1/2"				2"					
Pressure range bar	Bar	Steam [Nm ³ /h]																													
		0,2-0,8	0,5-2,5	2-8	12-20	0,2-0,8	0,5-2,5	2-8	12-20	0,2-0,8	0,5-2,5	2-8	12-20	0,2-0,8	2-8	12-20	0,2-0,8	2-8	12-20	0,2-0,8	2-8	12-20	0,2-0,8	2-8	12-20						
0,2	18				41				138				156				468				726				1172						
0,5	22	65			47	113			156	163			172	295			531	509			757	665			1265	1100					
0,8	25	70			52	120			172	173			191	305			547	541			820	700			1359	1173					
1		74				125				181				313				553				724				1222					
1,5		81				135				200				345				615				798				1345					
2		86	53	40		143	98	73		221	144	126		373	280	218		642	283	194		862	455	311		1451					
2,5		93	60	45		157	104	79		235	161	141		384	302	244		619	301	218		940	510	349		1535	787	663			
3			66	43			111	80			171	156			309	258			297	223			506	387			884	698			
4			79	53			129	79			187	160			339	308			333	244			499	428			876	670			
5			77	66			135	82			186	176			412	322			361	283			579	455			987	740			
6			78	75			132	88			212	200			388	326			441	323			707	518			1145	859			
7			84	81			118	93			225	198			275	298			429	363			740	635			1224	816			
8			89	89			123	96			249	190			254	279			475	402			821	645			1284	916			
9				89				98				193				250				441				707				1015			
10				97				106				192				273				480				770				1002			
11				94				106				189				262				472				833				1090			
12				101	79			105	78			204	183			282	247			406	457			814	570			1179	987		
13				84				68				174				189				489				610				1056			
14				90				57				162				201				521				650				1125			
15				95				54				123				213				552				590				1022			
16				94				51				130				180				584				728				1261			
17				99				46				110				142				615				768				1140			
18				96				32				87				150				576				693				1399			
19				101				28				61				105				604				606				1678			
20				105				21				32				165				632				634				1537			

Seat-Seal/Diaphragm Options

Option	Materials	Type	Working Temp.
NBR	Nitrile rubber (standard)	Elastomere flat seal 0,2 – 12 bar	-30°C to +130°C
FKM	Fluorocarbon	Elastomere flat seal 0,2 – 12 bar	-20°C to +200°C
EPDM	Ethylene propylene diene	Elastomere flat seal 0,2 – 12 bar	-50°C to +150°C
PTFE	Polytetrafluoroethylene	Flat seal 0,5 – 12 bar	-60°C to +225°C
If the seat seal is made of PTFE the O-rings of the body and setting spindle seal are made of FPM.			
Against surcharge			
PTFE	Polytetrafluoroethylene	Flat seal 12 – 20 bar	-60°C to +225°C

Bronze / Gunmetal Pressure Reducing Valve

Features

- Standard threaded connections:
 - Male thread BSP-T / Male thread BSP-T
- Version with female thread (available in sizes DN15, DN20 and DN25):
 - Female thread BSP-P / Female thread BSP-P
- Body gunmetal
- Suitable for neutral and non-neutral liquids, air, gases, vapours and warm water
- WRAS Approved
- EN 1567, ISO 3822, PED 2014/68/EU
- Marine Approvals - GL, LR EMEA, BV, ABS, RS
- ATEX Approval Available at Extra Cost
- 24 Month Warranty
- Test Certificate to EN10204-3.1 Available on Request

Typical Applications

- Potable water supply
- Process water supply in industrial and building technology
- Fire-fighting equipment and sprinkler systems
- Shipbuilding industry and offshore plants

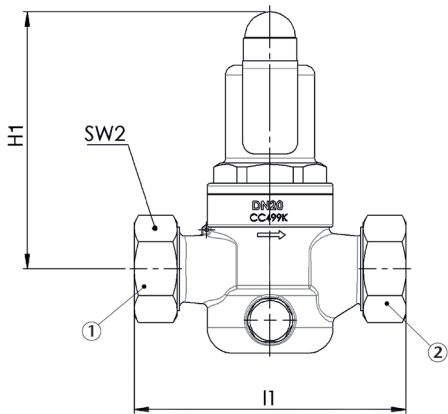
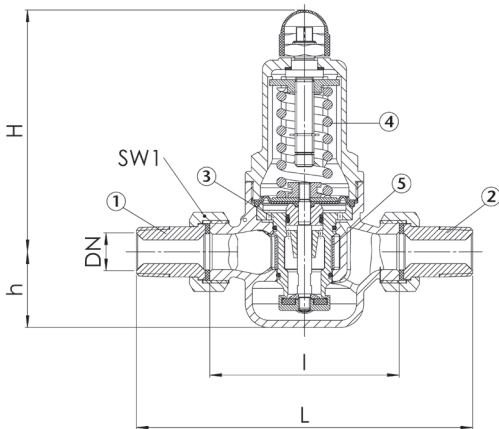

Technical Data

Inlet pressure:	Up to 40 bar
Outlet pressure:	0,5 to 15 bar
Working Temperature	EPDM or FKM Seal -10°C to +95°C

Dimensions in mm

This data sheet is designed as a guide and should not be regarded as wholly accurate in every detail. We reserve the right to amend the specification of any product without notice.

Connection	DN	½"	¾"	1"	1¼"	1½"	2"
Inlet pressure SP, HP up to	bar	40	40	40	40	40	40
Inlet pressure LP to	bar	25	25	25	25	25	25
Outlet pressure	bar	0.5 - 2	0.5 - 2	0.5 - 2	0.5 - 2	0.5 - 2	0.5 - 2
		1 - 8	1 - 8	1 - 8	1 - 8	1 - 8	1 - 8
		5 - 15	5 - 15	5 - 15	5 - 15	5 - 15	5 - 15
Installation dimensions	L	142	158	180	193	226	252
	in mm	I	80	90	100	105	130
	I1	85	95	105			
	H (H1)	102 (128')	102 (128')	130 (150')	130 (150')	165 (185')	165 (185')
	h	33	33	45	45	70	70
	SW1	30	37	46	52	65	75
	SW2	28	35	43	48	57	68
	Weight	kg	1.2 (1.5')	1.3 (1.6')	2.4 (2.9')	2.6 (3.1')	5.5 (6.2')
Coefficient of flow kvs	m³/h	3	3.5	6.7	7.6	12.5	15

¹ for type 681mGFO-LP

² The kvs value was determined according to DIN EN 60534-2-3. Instructions on how to determine size and capacity are to be found under section 2.

N.	Part Name	Materials
1	Inlet body	Bronze / Gunmetal CC499K
2	Outlet body	Bronze / Gunmetal CC499K
3	Internal parts	Bronze / Gunmetal CC499K Stainless Steel 1.4404
4	Spring	Spring steel with anti-rust protection 1.1200
5	Strainer	Stainless Steel 1.4404

Valve version

m	with diaphragm	High-quality, heat-resistant moulded elastomere, fabric-reinforced diaphragm. Pressure adjustment by means of non-rising spindle. Valve insert with balanced single seat valve completely made of stainless steel.
Complete valve insert SP/HP (order code: 681 Insert-DN...-seal) available as replacement part can be exchanged without removing the valve.		
Complete valve insert LP (order code: 681 LP Insert-DN...-seal) available as replacement part can be exchanged without removing the valve.		
Built-in dirt trap made of stainless steel.		
Mesh size:	DN 15 to DN 32	0,60 mm
	DN 40 and DN 50	0,75 mm

Medium

GF	gaseous and liquid	for water and distilled water, neutral and non-sticking liquids, compressed air and neutral gases; optionally with FPM elastomere seals for non-neutral media i.e. oils, fuels, oil-laden compressed air etc.
----	--------------------	---

Type of lifting mechanism

O	without lifting device
---	------------------------

Outlet pressure ranges

SP	Standard version	Inlet pressure: up to 40 bar	Outlet pressure: from 1 to 8 bar
HP	High-pressure version	Inlet pressure: up to 40 bar	Outlet pressure: from 5 to 15 bar
LP	Low-pressure version	Inlet pressure: up to 25 bar	Outlet pressure: from 0,5 to 2 bar
Fixed setting at a required outlet pressure against surcharge.			

Seat-Seal/Diaphragm Options

Option	Materials	Type	Working Temp.
EPDM	Ethylene propylene diene	Elastomere moulded diaphragm and seals approvals according to drinking water directive	-10°C to +95°C
Against surcharge			
FKM	Fluorocarbon	Elastomere moulded diaphragm and seals	-10°C to +95°C

Capacity charts

Art 681 M & F

Dimensioning by pressure loss on the outlet pressure side

Flow chart water

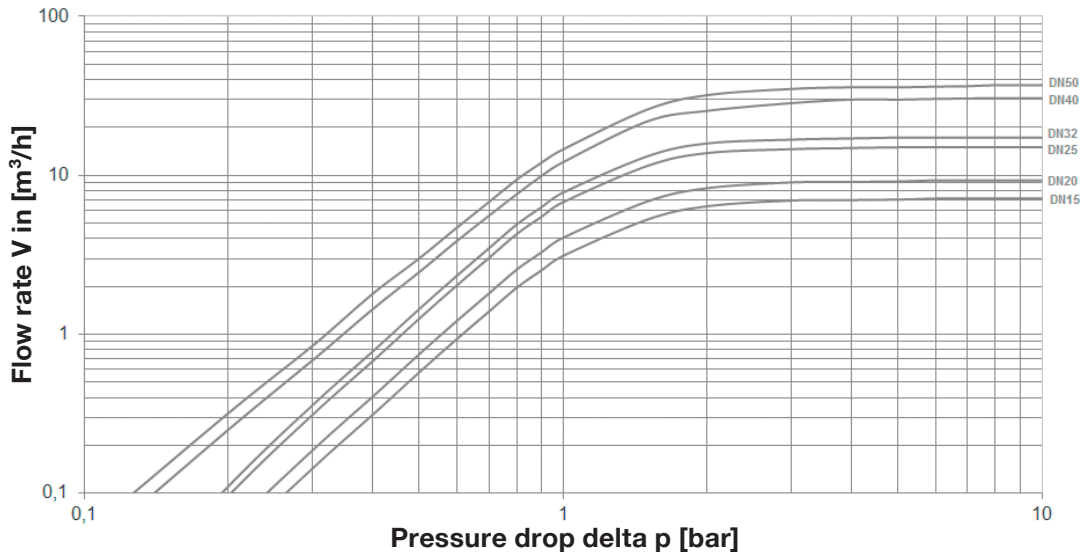

Dimensioning by flow velocity

For Liquids:

With help of the chart you can determine the nominal diameter (DN) for a given flow volume V (m³/h). The ideal flow velocity is between 1m/s – 2m/s.

For compressed air and other gaseous media:

The usual flow velocity for compressed air is 10 - 20 m/s. For gaseous media the flow volume V should always be shown in actual cubic meters/hour.

If the flow volume is given in standard cubic meters, these should be converted into actual cubic meters before using the diagram.

$$V (\text{m}^3/\text{h}) = \frac{V_{\text{Norm}} (\text{Nm}^3/\text{h})}{p_{\text{absolut}} (\text{bar})} = \frac{V_{\text{Norm}}}{p_0 + 1}$$

Actual cubic meters are based on the prevailing pressure of the medium on the outlet side of the pressure reducer.

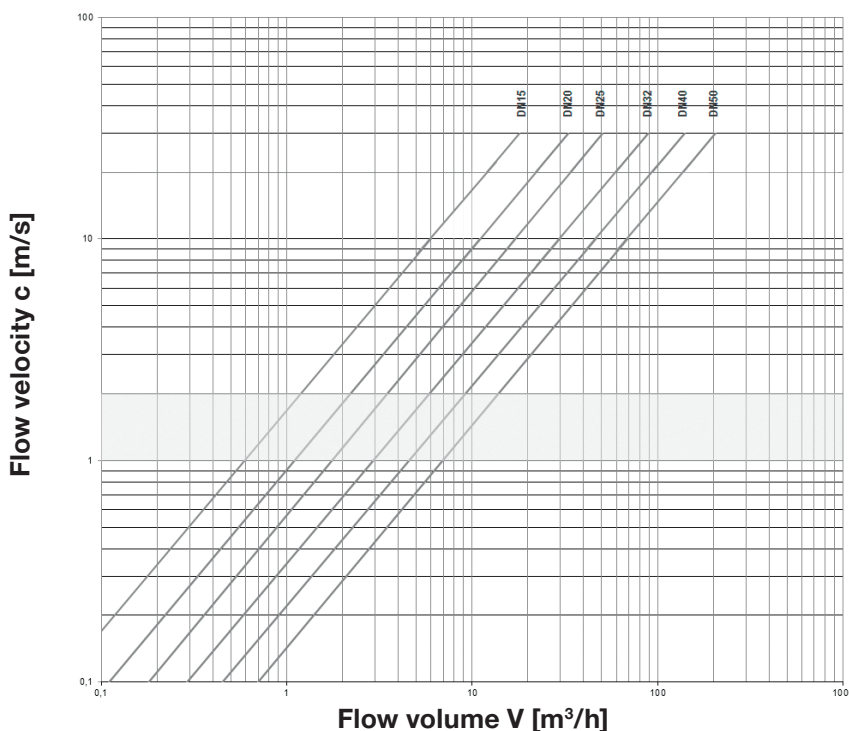

Dimensions in mm

This data sheet is designed as a guide and should not be regarded as wholly accurate in every detail. We reserve the right to amend the specification of any product without notice.

Stainless Steel Pressure Reducing Valve

Features

- Standard threaded connections: Male thread BSP-T / Male thread BSP-T
- Version with female thread (available in sizes DN15, DN20 and DN25): Female thread BSP-P / Female thread BSP-P
- Body stainless steel
- Suitable for neutral and non-neutral liquids, air, gases, vapours and warm water
- WRAS Approved
- EN 1567, ISO 3822, PED 2014/68/EU
- Marine Approvals - GL, LR EMEA, BV, ABS, RS
- ATEX Approval Available at Extra Cost
- 24 Month Warranty
- Test Certificate to EN10204-3.1 Available on Request

Typical Applications

- Potable water supply
- Process water supply in industrial and building technology
- Fire-fighting equipment and sprinkler systems
- Shipbuilding industry and offshore plants
- Secondary areas in the food, pharmaceutical and cosmetics industries

Connection	DN	1/2"	3/4"	1"	1 1/4"	1 1/2"	2"
Inlet pressure SP, HP up to	bar	40	40	40	40	40	40
Inlet pressure LP to	bar	25	25	25	25	25	25
Outlet pressure	bar	0.5 - 2	0.5 - 2	0.5 - 2	0.5 - 2	0.5 - 2	0.5 - 2
		1 - 8	1 - 8	1 - 8	1 - 8	1 - 8	1 - 8
		5 - 15	5 - 15	5 - 15	5 - 15	5 - 15	5 - 15
Installation dimensions	L	142	158	180	193	226	252
	in mm	I	80	90	100	105	130
	H (H1)	I1	85	95	105		
			102	102	130	130	165
		h	33	33	45	45	70
		SW1	30	37	46	52	65
		SW2	28	35	43	48	57
Weight	kg		1.2	1.3	2.3	2.5	5.2
			(1.5 ¹⁾)	(1.6 ¹⁾)	(2.8 ¹⁾)	(3.0 ¹⁾)	(5.9 ¹⁾)
Coefficient of flow kvs	m ³ /h	3	3.5	6.7	7.6	12.5	15

¹for type 481mGFO-LP

²The kvs value was determined according to DIN EN 60534-2-3. Instructions on how to determine size and capacity are to be found under section 2.

N. Part Name	Materials
1 Inlet body	Stainless steel 1.4408
2 Outlet body	Stainless steel 1.4408
3 Internal parts	Stainless steel 1.4408, 1.4404
4 Spring	Spring steel with anti-rust protection 1.1200
5 Strainer	Stainless steel 1.4404

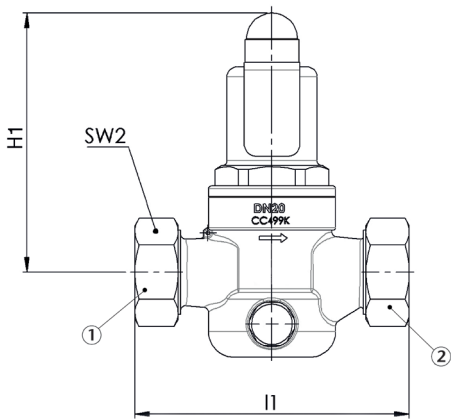
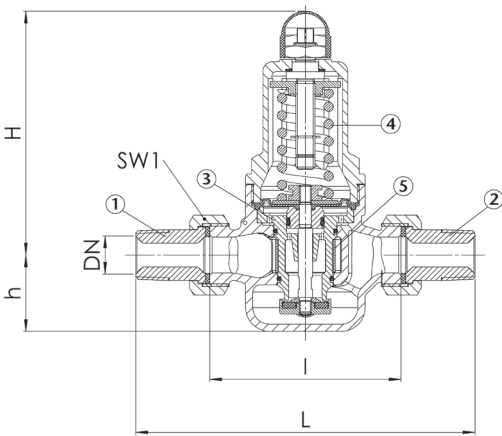
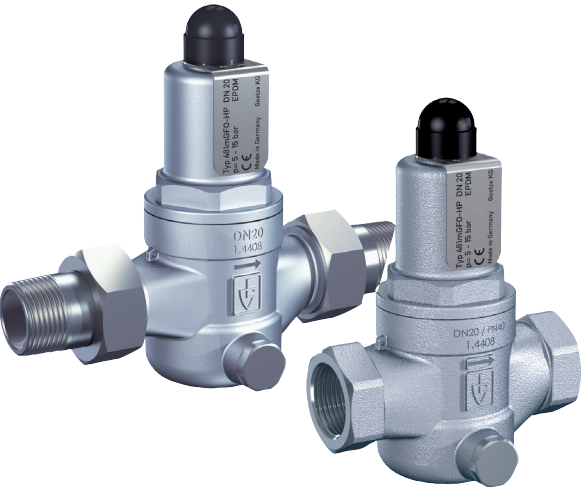

Technical Data

Inlet pressure:	up to 40 bar
Outlet pressure:	0,5 to 15 bar
Working Temperature	EPDM or FKM Seal -10°C to +95°C

Dimensions in mm

This data sheet is designed as a guide and should not be regarded as wholly accurate in every detail. We reserve the right to amend the specification of any product without notice.

Valve version

m	with diaphragm	High-quality, heat-resistant moulded elastomere, fabric-reinforced diaphragm. Pressure adjustment by means of non-rising spindle. Valve insert with balanced single seat valve completely made of stainless steel.
Complete valve insert SP/HP (order code: 481 Insert-DN...-seal) available as replacement part can be exchanged without removing the valve.		
Complete valve insert LP (order code: 481 LP Insert-DN...-seal) available as replacement part can be exchanged without removing the valve.		
Built-in dirt trap made of stainless steel.		
Mesh size:	DN 15 to DN 32	0,60 mm
	DN 40 and DN 50	0,75 mm

Medium

GF	gaseous and liquid	for water and distilled water, neutral and non-sticking liquids, compressed air and neutral gases; optionally with FPM elastomere seals for non-neutral media i.e. oils, fuels, oil-laden compressed air etc.
----	--------------------	---

Type of lifting mechanism

O	without lifting device
---	------------------------

Outlet pressure ranges

SP	Standard version	Inlet pressure: up to 40 bar	Outlet pressure: from 1 to 8 bar
HP	High-pressure version	Inlet pressure: up to 40 bar	Outlet pressure: from 5 to 15 bar
LP	Low-pressure version	Inlet pressure: up to 25 bar	Outlet pressure: from 0,5 to 2 bar
Fixed setting at a required outlet pressure against surcharge.			

Seat-Seal/Diaphragm Options

Option	Materials	Type	Working Temp.
EPDM	Ethylene propylene diene	Elastomere moulded diaphragm and seals approvals according to drinking water directive	-10°C to +95°C
Against surcharge			
FKM	Fluorocarbon	Elastomere moulded diaphragm and seals	-10°C to +95°C

Capacity charts

Art 481 M & F

Dimensioning by pressure loss on the outlet pressure side

Flow chart water

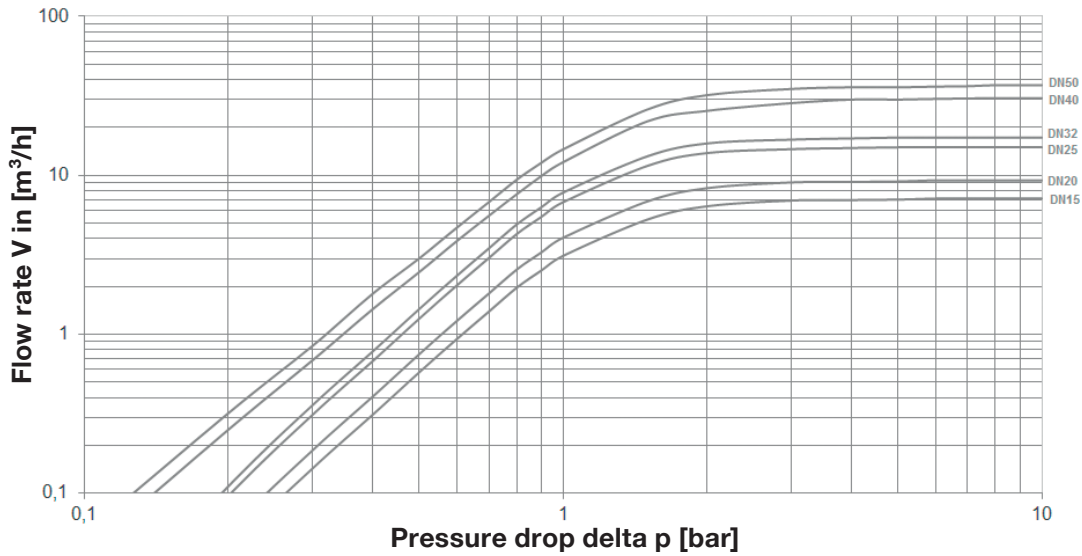

Dimensioning by flow velocity

For Liquids:

With help of the chart you can determine the nominal diameter (DN) for a given flow volume V (m^3/h). The ideal flow velocity is between 1m/s – 2m/s.

For compressed air and other gaseous media:

The usual flow velocity for compressed air is 10 - 20 m/s. For gaseous media the flow volume V should always be shown in actual cubic meters/hour.

If the flow volume is given in standard cubic meters, these should be converted into actual cubic meters before using the diagram.

$$V (m^3/h) = \frac{V_{Norm} (Nm^3/h)}{p_{absolut} (bar)} = \frac{V_{Norm}}{p_0 + 1}$$

Actual cubic meters are based on the prevailing pressure of the medium on the outlet side of the pressure reducer.

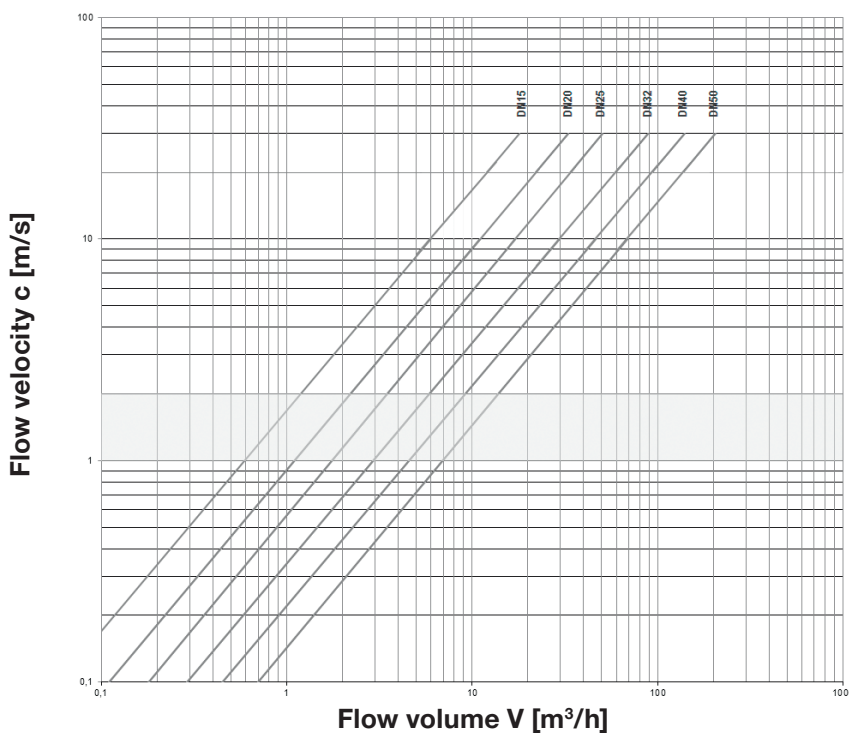

Dimensions in mm

This data sheet is designed as a guide and should not be regarded as wholly accurate in every detail. We reserve the right to amend the specification of any product without notice.

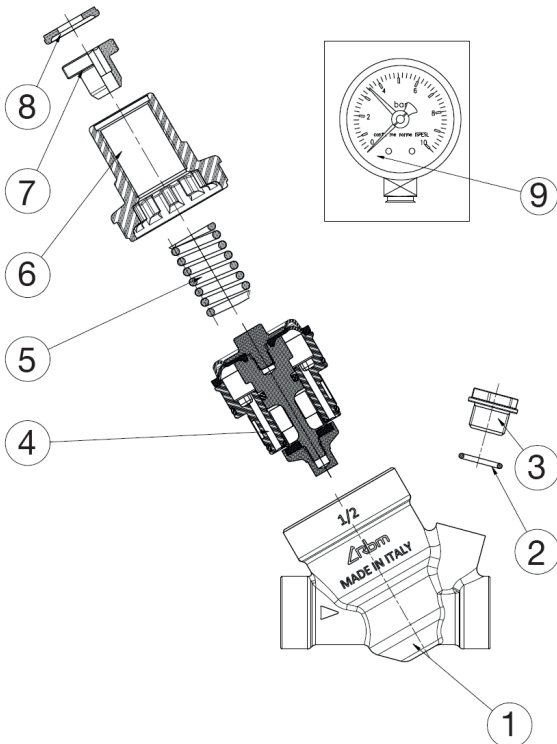
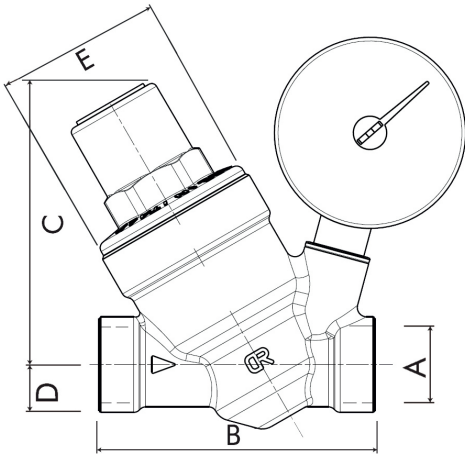

Pressure Reducing Valve with gauge

Features

- Controls static and dynamic pressure
- Conforms to BS EN 1567
- Easy to service high temperature cartridge
- AISI 304 stainless steel cartridge filter
- Supplied with a pressure gauge
- WRAS Approved
- 1/2" & 3/4" BSP Parallel Female Ends (ISO 228/1)

Cavitation Chart

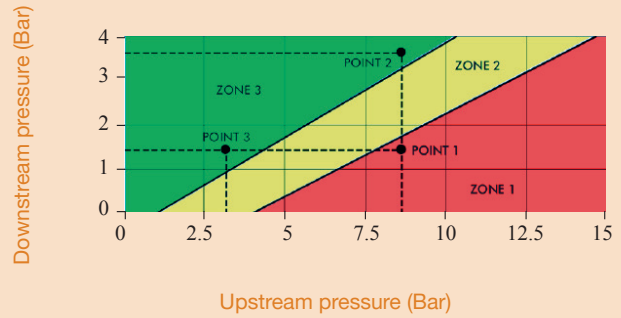

A	1/2"	3/4"
B	75	78
C	76	77
D	18	16
E	46	46

No.	Part Name	Materials
1	Body	Cw602N
2	O-Ring	EPDM + Perox
3	Plug	PA66 + 30% f.d.v.
4	Cartridge	PA66+30%F.V. + colouring MACROVERS 564FA.
5	Spring	EN 0270-3-1.4310
6	Bonnet	PA66+30% f.d.v.
7	Adjustable Plug	Cw614N
8	Plastic Cap	PC / ABS
9	Pressure gauge	

Technical Data

Max inlet pressure (static)	16 Bar
Adjustable pressure range	0.5 - 6 Bar
Min inlet pressure	0.5 Bar
Max inlet temperature	80°C
Factory set pressure	3 Bar

Dimensions in mm

This data sheet is designed as a guide and should not be regarded as wholly accurate in every detail. We reserve the right to amend the specification of any product without notice.

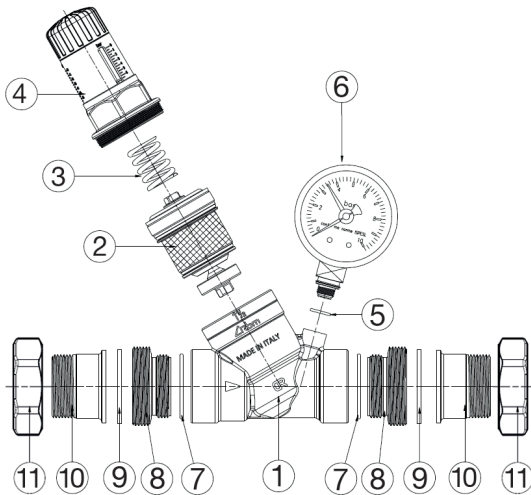
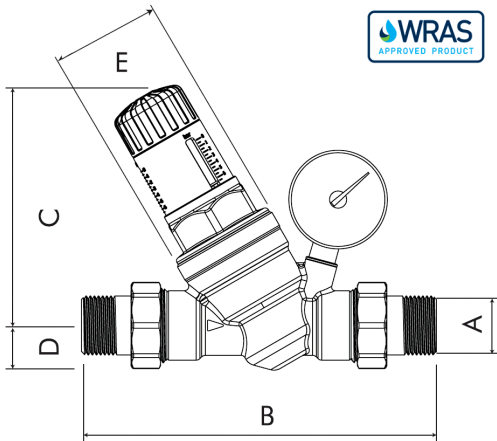

Pressure Reducing Valve with gauge

Features

- Controls static and dynamic pressure
- Conforms to BS EN 1567
- Easy to service high temperature cartridge
- AISI 304 stainless steel cartridge filter
- Supplied with a pressure gauge
- WRAS Approved
- 1" to 2" BSP Parallel Male Ends (ISO 228/1)

Cavitation Chart

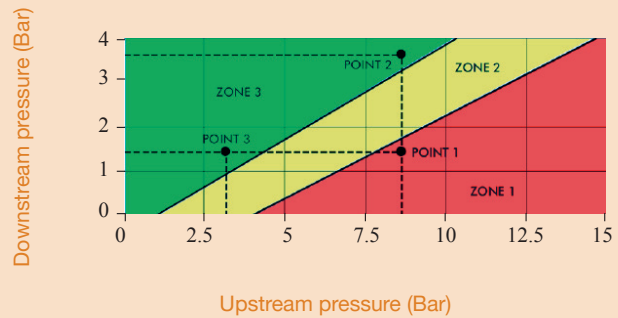

	1"	1 1/4"	1 1/2"	2"
A	199	217	236	269
B	134	138	144	146
C	24	30	37	47
D	61	61	61	61
E	61	61	61	61

No.	Part Name	Materials
1	Body	Cw602N
2	Cartridge	PA66 + 30% f.d.v.
3	Spring	EN 0270-3-1.431
4	Adjustable knob	PA66 + 30% f.d.v.
5	O-Ring	EPDM + Perox
6	Pressure gauge	
7	O-Ring	EPDM + Perox
8	Adaptor	CW617N
9	Gasket	EPDM + Perox
10	Male Union End	Cw617N
11	Nut	Cw602N

Technical Data

Max inlet pressure (static)	16 Bar
Adjustable pressure range	0.5 - 6 Bar
Min inlet pressure	0.5 Bar
Max inlet temperature	80°C
Factory set pressure	3 Bar

Dimensions in mm

This data sheet is designed as a guide and should not be regarded as wholly accurate in every detail. We reserve the right to amend the specification of any product without notice.

Pressure Reducing Valve with gauge



Features

- 22mm with 15mm adaptors (adaptors supplied loose)
- Conforms to BS EN 1567
- Supplied with a loose pressure gauge
- Compression ends (BS EN1254-2)
- WRAS Approved

Cavitation Chart

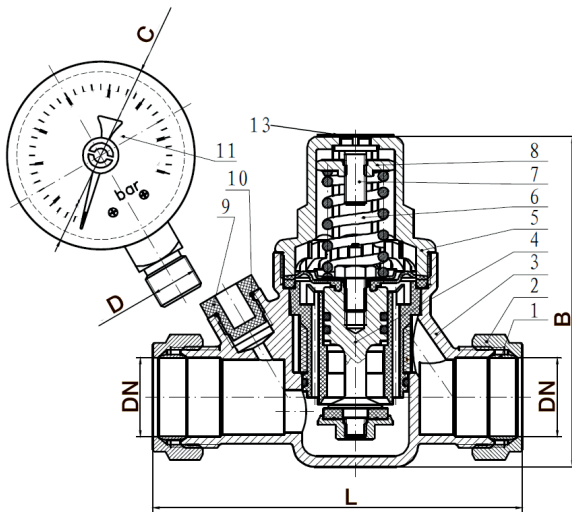
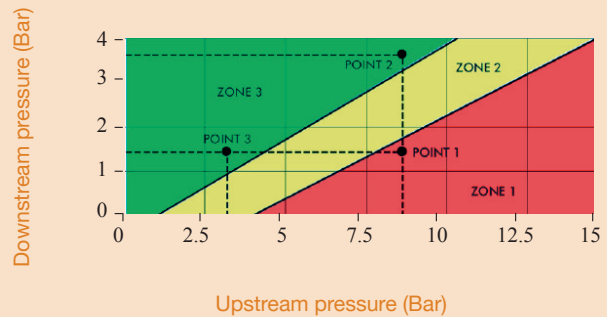

15mm Adaptor

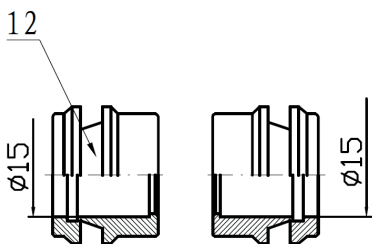

	15mm	22mm
L	123	104
B	92.5	92.5
C	52.5	52.5
D	1/4"	1/4"
Kgs	0.61	0.54

No.	Part Name	Materials
1	Olives	Copper - T2
2	Nuts	DZR - CW602N
3	Body	DZR - CW602N
4	Cartridge	Brass - CW617N
5	Plastic Cap	Nylon
6	Spring	Spring Steel
7	Screw	Brass - Hpb58-3
8	Nut	Brass - Hpb58-3
9	Plug	Nylon
10	O-Ring	EPDM
11	Gauge	Steel - Q235A
12	Reducer	DZR - CW602N
13	Pre-set Label	

Technical Data

Max inlet pressure (static)	16 Bar
Adjustable pressure range	1 - 6 Bar
Pressure Gauge	0 - 10 Bar
Min inlet pressure	1 Bar
Max inlet temperature	80°C
Factory set pressure	3 Bar

Dimensions in mm

This data sheet is designed as a guide and should not be regarded as wholly accurate in every detail. We reserve the right to amend the specification of any product without notice.



Bronze / Gunmetal Pressure Reducing Valve

Features

- Flange connection (DIN EN 1092)
- Suitable for neutral and non-neutral liquids, air, gases, vapours and warm water
- WRAS Approved
- DIN DVGW guidelines, PED 2014/68/EU
- 24 Month Warranty
- Gauges available on request

Typical Applications

- Protection of domestic water supply systems
- Protection of commercial and industrial plants against an excess supply pressure
- Potable water supply according to DIN 1988
- Process water supply in industrial- and building technology
- Fire-fighting equipment and sprinkler systems
- Shipbuilding industry and offshore plants

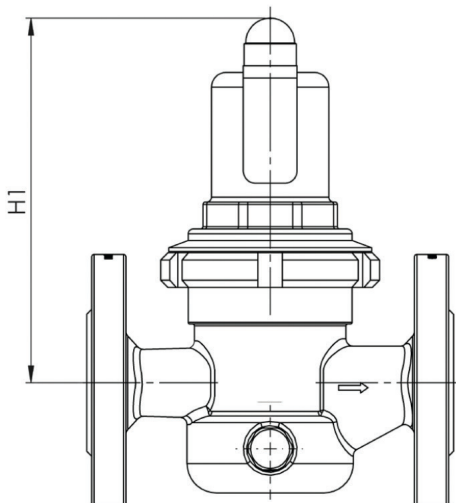
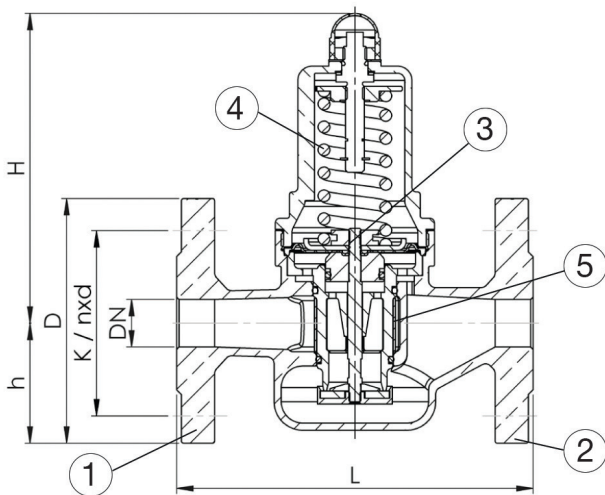

Connection	DN	15	20	25	32	40	50	65	80	100
Inlet pressure SP, HP up to	Bar	40	40	40	40	40	40	40	40	16
Inlet pressure LP to	Bar	25	25	25	25	25	25			
Outlet pressure	Bar	0.5-2	0.5-2	0.5-2	0.5-2	0.5-2	0.5-2	1-8	1-8	1-8
		1-8	1-8	1-8	1-8	1-8	1-8			5-13
		5-15	5-15	5-15	5-15	5-15	5-15			
Installation dimensions in mm	D	95	105	115	140	150	165	185	200	220
	L	130	150	160	180	200	230	290	310	350
	H	102	130	130	130	165	165	235	235	320
	(H1)	(128')	(150')	(150')	(150')	(185')	(185')			
	h	46	50	55	68	73	80	89	96	112
	K / nxd	65 / 4xM12	75 / 4xM12	85 / 4xM12	100 / 4xM16	110 / 4xM16	125 / 4xM16	145 / 8xM16	160 / 8xM16	180 / 8xM16
Weight	Kg	2.8 (3.1')	4.2 (4.6')	4.7 (5.1')	5.9 (6.3')	8.6 (9.3')	10.5 (11.2')	20	22	40
Coefficient of flow kvs ²	m ³ /h	3	5.8	6.7	7.6	12.5	15	40	50	80

¹ for type 682mGFO-LP

² The kvs value was determined according to DIN EN 60534-2-3. Instructions on how to determine size and capacity are to be found under section 2.

Technical Data

Inlet Pressure: Up to 40 Bar
 Outlet Pressure: 0.5 to 15 Bar
 Working Temperature: -20°C to +120°C*
 *See additional info on pg.2

Dimensions in mm

This data sheet is designed as a guide and should not be regarded as wholly accurate in every detail. We reserve the right to amend the specification of any product without notice.

No.	Part Name	Materials
1	Inlet Body	Bronze / Gunmetal CC499K
2	Outlet Body	Bronze / Gunmetal CC499K
3	Internal Parts	Bronze / Gunmetal CC499K Stainless Steel 1.4404
4	Spring	Spring steel with anti-rust protection 1.1200
5	Strainer	Stainless Steel 1.4404

Valve version

m	with diaphragm	High-quality, heat-resistant moulded elastomere, fabric-reinforced diaphragm. Pressure adjustment by means of non-rising spindle. Valve insert with balanced single seat valve completely made of stainless steel.
Complete valve cartridge SP/HP (order code: 482 Insert-DN...-seal) available as replacement part can be exchanged without removing the valve.		
Complete valve cartridge LP (order code: 482 LP Insert-DN...-seal) available as replacement part can be exchanged without removing the valve.		
Built-in dirt trap made of stainless steel.		
Mesh size:	DN 15 to DN 32	0,60 mm
	DN 40 and DN 80	0,75 mm

Medium

GF	gaseous and liquid	for water, neutral and non-sticking liquids, compressed air and neutral gases; optionally with FPM elastomere seals for non-neutral media i.e. oils, fuels, oil-laden compressed air etc. Not suitable with steam.
----	--------------------	--

Type of lifting mechanism

O	without lifting device
---	------------------------

Outlet pressure ranges

SP	Standard version	Inlet pressure: up to 40 bar	Outlet pressure: from 1 to 8 bar
HP	High-pressure version (not for DN65 and DN80)	Inlet pressure: up to 40 bar	Outlet pressure: from 5 to 15 bar
LP	Low-pressure version (not for DN65, DN80 and DN100)	Inlet pressure: up to 25 bar	Outlet pressure: from 0,5 to 2 bar

Seal Options

Option	Materials	Type	Working Temp.
EPDM	Ethylene propylene diene	Elastomere moulded diaphragm and seals approvals according to drinking water directive	-20°C to +120°C (up to 8 bar outlet pressure) -20°C to +95°C (from 8 bar outlet pressure)
FKM	Fluorocarbon	Elastomere moulded diaphragm and seals	-10°C to +120°C (up to 8 bar outlet pressure) -10°C to +95°C (from 8 bar outlet pressure)

Capacity charts

ART 682

Dimensioning by pressure loss on the outlet pressure side

Flow chart water

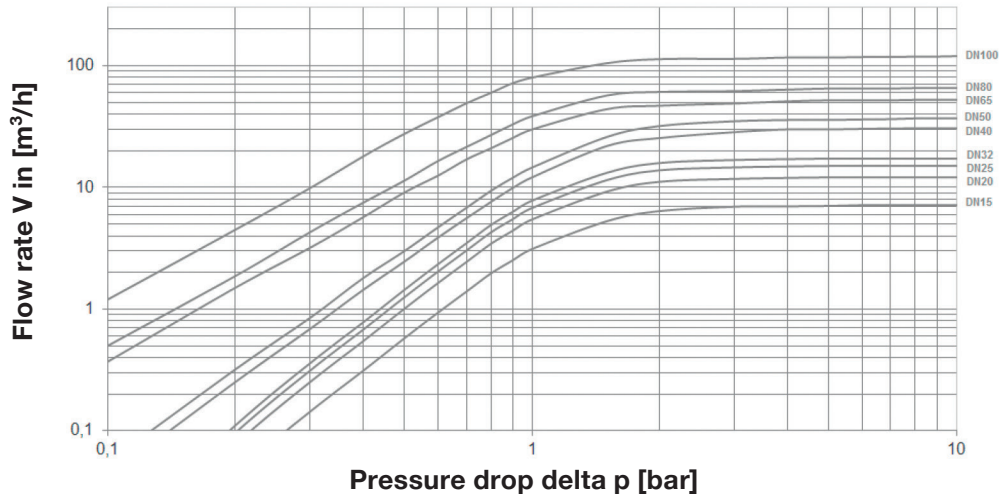

Dimensioning by flow velocity

For Liquids:

With help of the chart you can determine the nominal diameter (DN) for a given flow volume V (m³/h). According to DVGW-guidelines (DIN 1988) a flow velocity of 2 m/s in domestic water supply systems should not be exceeded.

For compressed air and other gaseous media:

The usual flow velocity for compressed air is 10 - 20 m/s. For gaseous media the flow volume V should always be shown in actual cubic meters/hour.

If the flow volume is given in standard cubic meters, these should be converted into actual cubic meters before using the diagram.

$$V (\text{m}^3/\text{h}) = \frac{V_{\text{Norm}} (\text{Nm}^3/\text{h})}{p_{\text{absolut}} (\text{bar})} = \frac{V_{\text{Norm}}}{p_{\text{U}} + 1}$$

Actual cubic meters are based on the prevailing pressure of the medium on the outlet side of the pressure reducer.

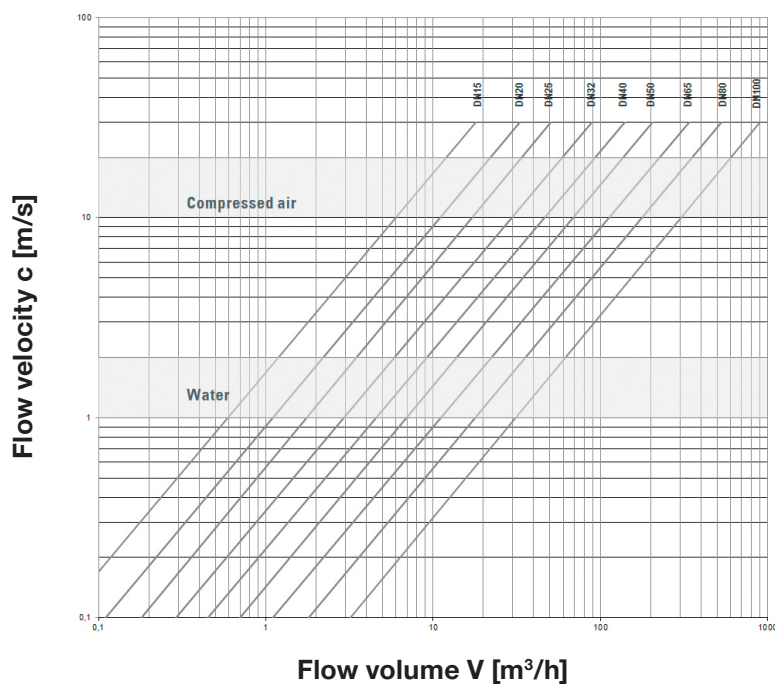

Dimensions in mm

This data sheet is designed as a guide and should not be regarded as wholly accurate in every detail. We reserve the right to amend the specification of any product without notice.

PN16 Adjustable Pressure Reducing Valve

Features

- Automatic Control Valve
- Suitable for potable water applications
- WRAS approved epoxy coated body
- Pressure adjusted by Integral Pilot Valve
- Conforms to BS EN 558-1 Series 1
- Flange conforms to BS EN 1092 PN16
- Available flanged PN25
- Stainless steel pilot tubing and valves

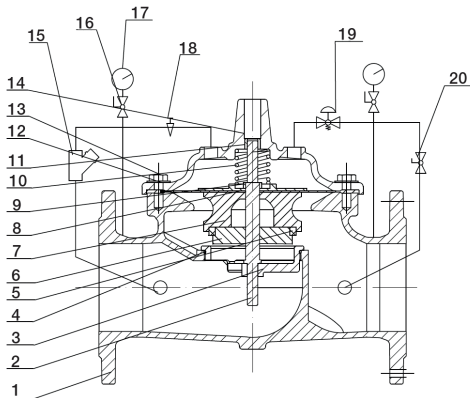
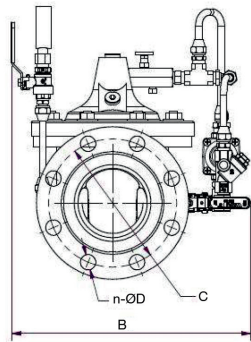
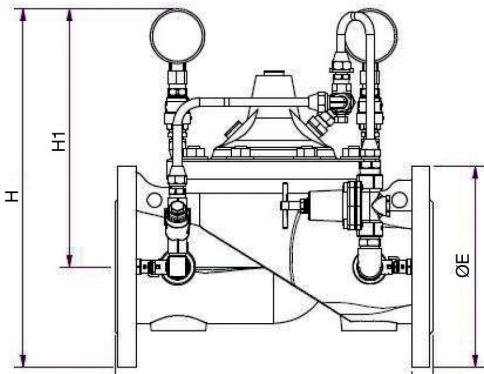

Pressure/Temperature

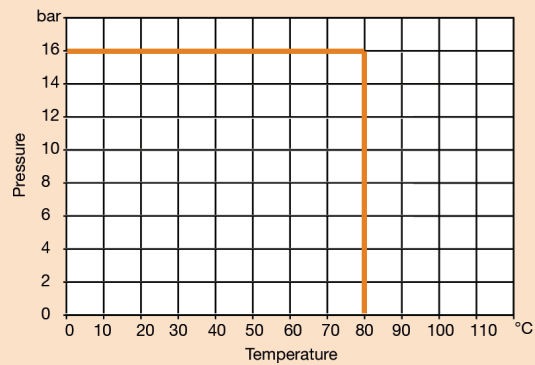

DN	50	65	80	100	125	150	200	250	300
L	230	290	310	350	400	480	600	730	850
E	165	185	200	220	250	285	340	405	460
C	125	145	160	180	210	240	295	355	410
n-d	4-Ø19	4-Ø19	8-Ø19	8-Ø19	8-Ø19	8-Ø23	12-Ø23	12-Ø28	12-Ø28
B	265	300	310	320	350	385	440	505	560
H	452	462	470	483	498	513	540	573	598
H1	369	370	370	373	373	376	376	378	396
Kgs	13	17	23	30	65	69	132	315	420

N.	Part Name	Materials
1	Body	Ductile Iron
2	Stem	Stainless Steel 304
3	Seat	Stainless Steel 304
4	O-Ring	NBR
5	Disc Ring	NBR
6	Disc Retailer	Ductile Iron
7	Disc Guide	Ductile Iron
8	Diaphragm	EPDM
9	Diaphragm Washer	Ductile Iron
10	Spring	Stainless Steel 304
11	Cover Bearing	Stainless Steel 304
12	Screw	Stainless Steel 304
13	Washer	Stainless Steel 304
14	Cover	Ductile Iron
15	Strainer	Stainless Steel 304
16	Ball Valve	Stainless Steel 304
17	Gauge	Stainless Steel 304
18	Needle Valve	Stainless Steel 304
19	Pilot Valve	Stainless Steel 304
20	Ball Valve	Stainless Steel 304

Technical Data

Max Pressure	16 Bar
Working Temperature	0°C to +80°C

Dimensions in mm

This data sheet is designed as a guide and should not be regarded as wholly accurate in every detail. We reserve the right to amend the specification of any product without notice.

Pilot Valve Detail - ART 6250

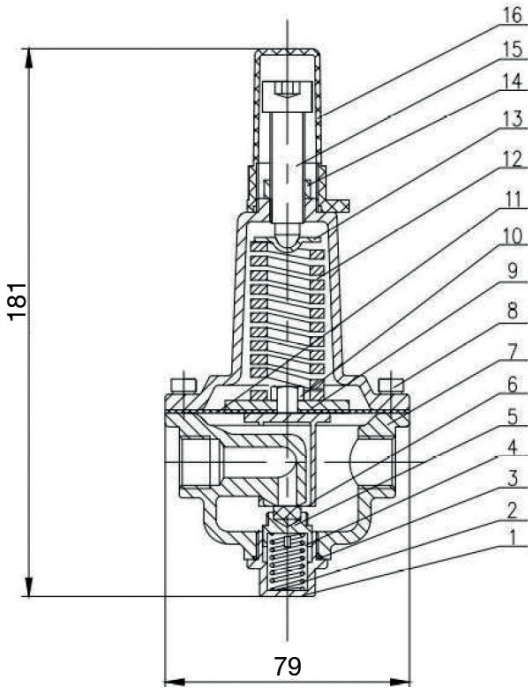

Fitted with standard Pilot Valve
0.70 to 12.00 Bar (10 to 175 PSI)
Factory set to 3.5 Bar (50 PSI)

Other Pilot Valves available
1.40 to 12.00 Bar (20 to 175 PSI)
2.10 to 20.00 Bar (30 to 300 PSI)

Pilot Valve

N.	Part Name	Materials
1	Plug	Stainless Steel 304
2	Spring	Stainless Steel 304
3	O-Ring	NBR
4	Seat	Stainless Steel 304
5	Disc	NBR
6	Yoke	Stainless Steel 304
7	Body	Stainless Steel 304
8	Screw	Stainless Steel 304
9	Diaphragm Washer	Stainless Steel 304
10	Nut	Stainless Steel 304
11	Diaphragm	EPDM
12	Spring	Stainless Steel 304
13	Spring Holder	Stainless Steel 304
14	Locking Nut	Stainless Steel 304
15	Adjusting Screw	Stainless Steel 304
16	Cap	ABS

Operation Cavitation Chart

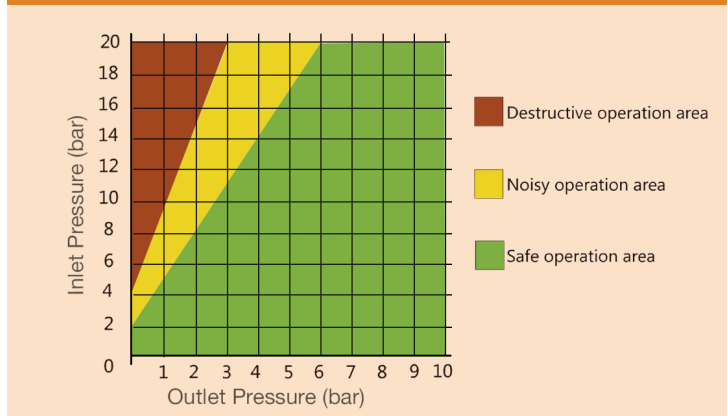

Flow curve of the main valve at fully open status

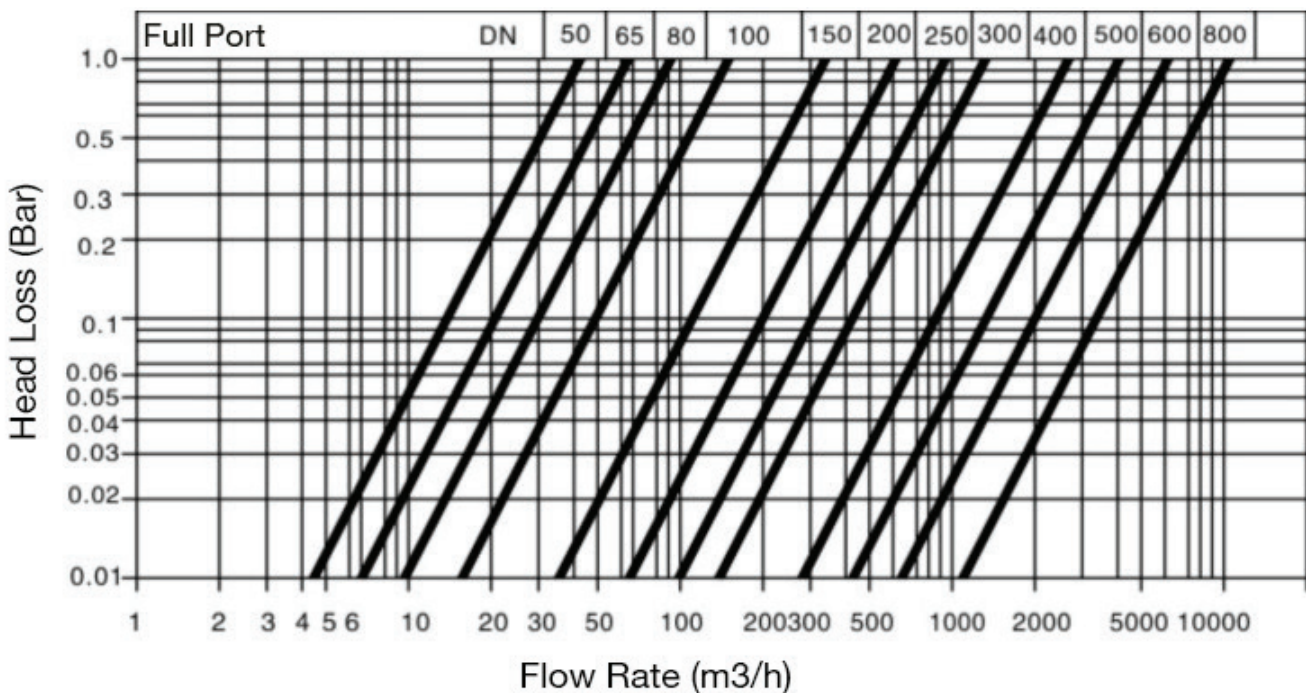

ANSI Adjustable Pressure Reducing Valve

Features

- Automatic Control Valve
- Suitable for potable water applications
- WRAS approved epoxy coated body
- Pressure adjusted by Integral Pilot Valve
- Conforms to BS EN 558-1 Series 1
- Flange conforms to ANSI 150 (B16.42)
- Available Flanged ANSI Class 300
- Stainless steel pilot tubing and valves

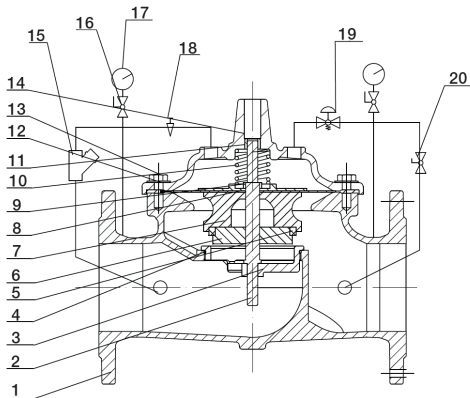
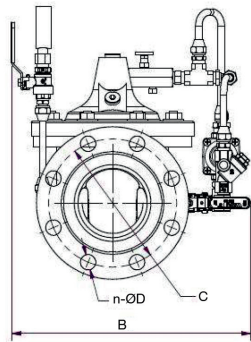
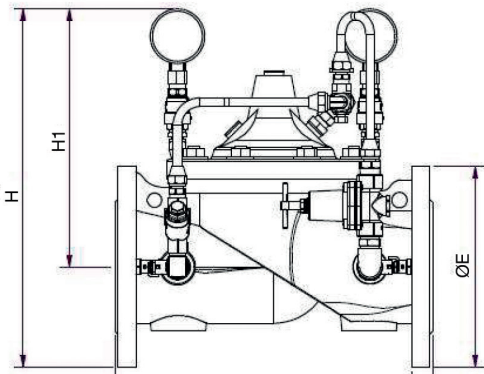

Technical Data

Max Pressure	16 Bar
Working Temperature	0°C to +80°C

Dimensions in mm

This data sheet is designed as a guide and should not be regarded as wholly accurate in every detail. We reserve the right to amend the specification of any product without notice.

Pressure/Temperature

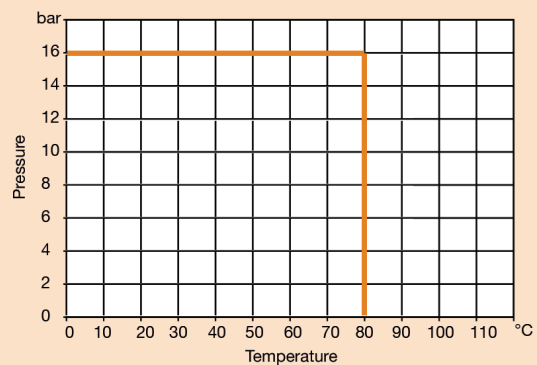

DN	50	65	80	100	125	150	200	250	300
L	230	290	310	350	400	480	600	730	850
E	152.4	177.8	190.5	228.6	254.0	279.4	342.9	406.4	482.6
C	120.7	139.7	152.4	190.5	215.9	241.3	298.5	362.0	431.8
n-d	4- Ø19	4- Ø19	4- Ø19	8- Ø19	8- Ø22.4	8- Ø22.4	8- Ø22.4	12- Ø25.4	12- Ø25.4
B	265	300	310	320	350	385	440	505	560
H	452	462	470	483	498	513	540	573	598
H1	369	370	370	373	373	376	376	378	396
Kgs	13	17	23	30	65	69	132	315	420

N.	Part Name	Materials
1	Body	Ductile Iron
2	Stem	Stainless Steel 304
3	Seat	Stainless Steel 304
4	O-Ring	NBR
5	Disc Ring	NBR
6	Disc Retailer	Ductile Iron
7	Disc Guide	Ductile Iron
8	Diaphragm	EPDM
9	Diaphragm Washer	Ductile Iron
10	Spring	Stainless Steel 304
11	Cover Bearing	Stainless Steel 304
12	Screw	Stainless Steel 304
13	Washer	Stainless Steel 304
14	Cover	Ductile Iron
15	Strainer	Stainless Steel 304
16	Ball Valve	Stainless Steel 304
17	Gauge	Stainless Steel 304
18	Needle Valve	Stainless Steel 304
19	Pilot Valve	Stainless Steel 304
20	Ball Valve	Stainless Steel 304

Pilot Valve Detail - ART 6250

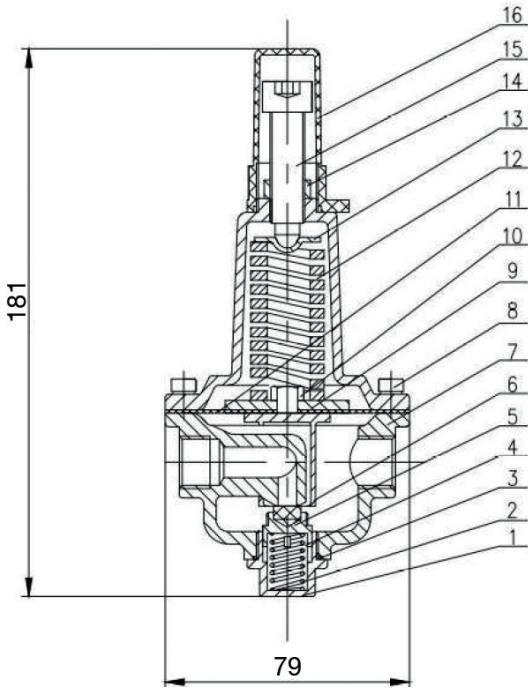

Fitted with standard Pilot Valve
0.70 to 12.00 Bar (10 to 175 PSI)
Factory set to 3.5 Bar (50 PSI)

Other Pilot Valves available
1.40 to 12.00 Bar (20 to 175 PSI)
2.10 to 20.00 Bar (30 to 300 PSI)

Pilot Valve

N.	Part Name	Materials
1	Plug	Stainless Steel 304
2	Spring	Stainless Steel 304
3	O-Ring	NBR
4	Seat	Stainless Steel 304
5	Disc	NBR
6	Yoke	Stainless Steel 304
7	Body	Stainless Steel 304
8	Screw	Stainless Steel 304
9	Diaphragm Washer	Stainless Steel 304
10	Nut	Stainless Steel 304
11	Diaphragm	EPDM
12	Spring	Stainless Steel 304
13	Spring Holder	Stainless Steel 304
14	Locking Nut	Stainless Steel 304
15	Adjusting Screw	Stainless Steel 304
16	Cap	ABS

Operation Cavitation Chart

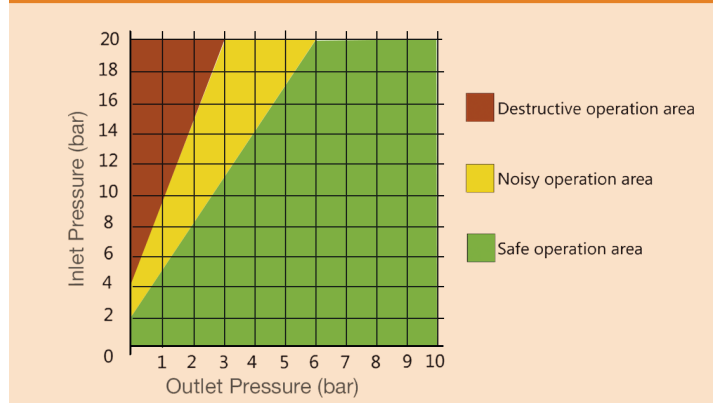

Flow curve of the main valve at fully open status

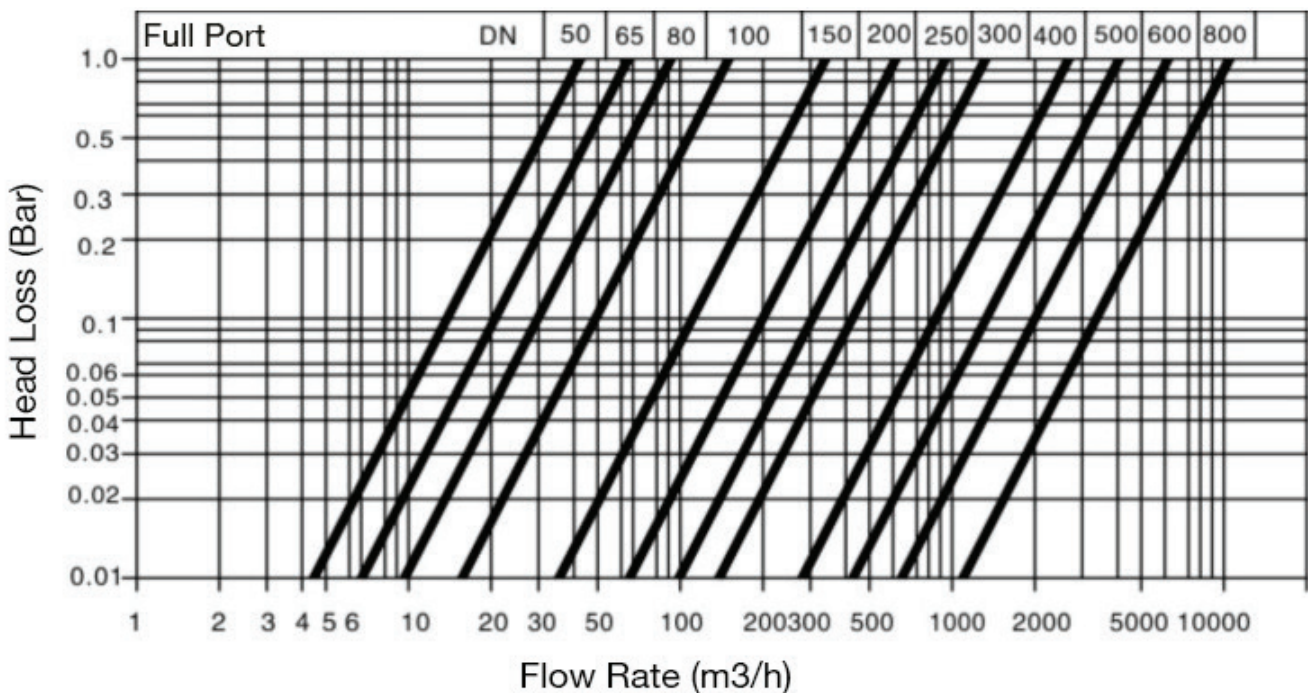

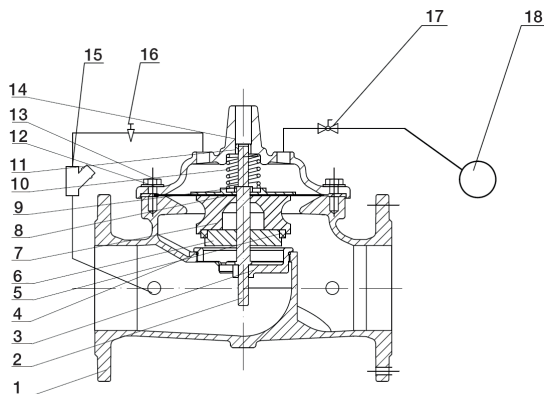
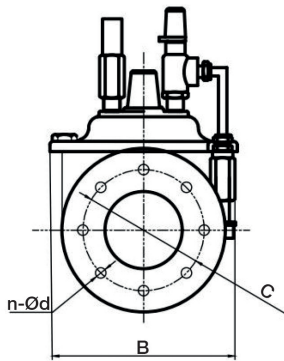
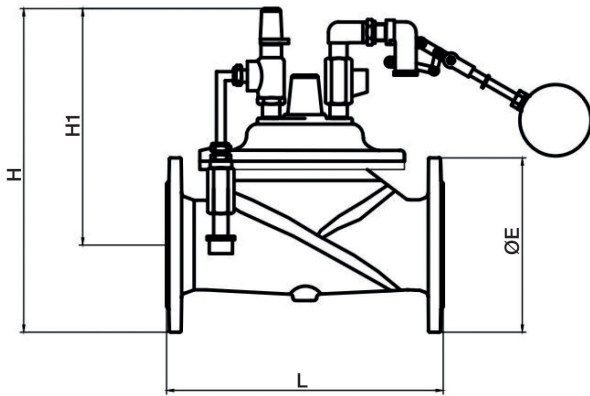

PN16 Float Control Valve

Features

- Automatic Control Valve
- Suitable for Potable Water Applications
- WRAS Approved Epoxy Coated Body
- Conforms to BS EN 558-1 Series 1
- Flange Conforms to BS EN 1092 PN16
- Available flanged PN25
- Stainless Steel Pilot Tubing and Valves
- Copper Float Option

Pressure/Temperature

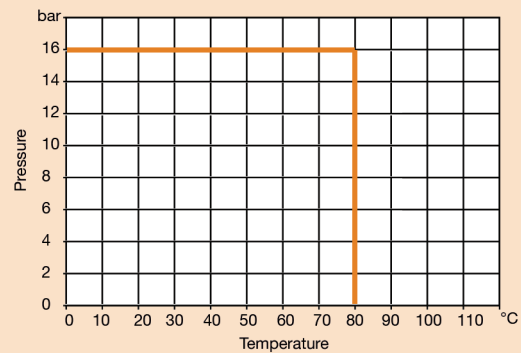

DN	50	65	80	100	125	150	200	250	300
L	230	290	310	350	400	480	600	730	850
E	165	185	200	220	250	285	340	405	460
C	125	145	160	180	210	240	295	355	410
n-d	4- Ø19	4- Ø19	8- Ø19	8- Ø19	8- Ø19	8- Ø23	12- Ø23	12- Ø28	12- Ø28
B	164	194	218	252	286	348	476	574	662
H	335	355	370	390	420	455	510	575	630
H1	242	252	270	280	295	313	340	372	400
Kgs	13	17	23	30	65	69	132	315	420

N.	Part Name	Materials
1	Body	Ductile Iron
2	Stem	Stainless Steel 304
3	Seat	Stainless Steel 304
4	O-Ring	NBR
5	Disc Ring	NBR
6	Disc Retailer	Ductile Iron
7	Disc Guide	Ductile Iron
8	Diaphragm	EPDM
9	Diaphragm Washer	Ductile Iron
10	Spring	Stainless Steel 304
11	Cover Bearing	Stainless Steel 304
12	Screw	Stainless Steel 304
13	Washer	Stainless Steel 304
14	Cover	Ductile Iron
15	Strainer	Stainless Steel 304
16	Needle Valve	Stainless Steel 304
17	Ball Valve	Stainless Steel 304
18	Float Control Valve	Stainless Steel 304

Technical Data

Max Pressure	16 Bar
Minimum Differential Pressure	5PSI (0.035MPa)
Working Temperature	0°C to +80°C

Dimensions in mm

This data sheet is designed as a guide and should not be regarded as wholly accurate in every detail. We reserve the right to amend the specification of any product without notice.

Pilot Valve Detail - ART 6150

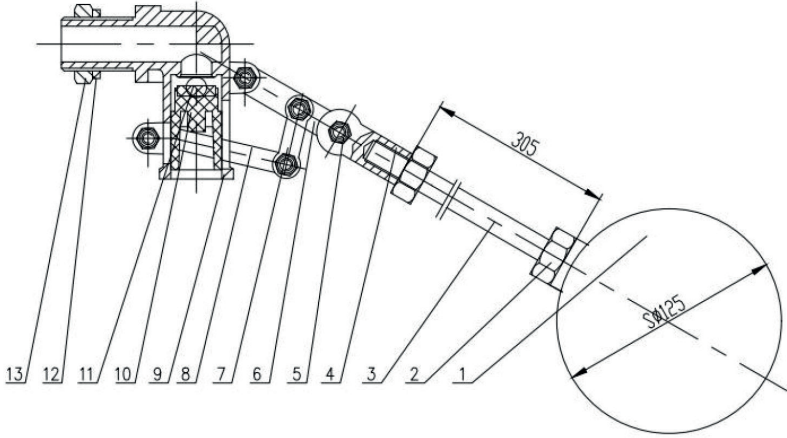

Pilot Valve

N.	Part Name	Materials
1	Float Ball	Stainless Steel 304
2	Nut	Stainless Steel 304
3	Rod	Stainless Steel 304
4	Level Holder	Stainless Steel 304
5	Screw / Nut	Stainless Steel 304
6	Arm	Stainless Steel 304
7	Level	Stainless Steel 304
8	Seat Holder	Stainless Steel 304
9	Body	Stainless Steel 304
10	Yoke	Stainless Steel 304
11	Seat	NBR
12	Washer	NBR
13	Nut	Stainless Steel 304

Flow curve of the main valve at fully open status

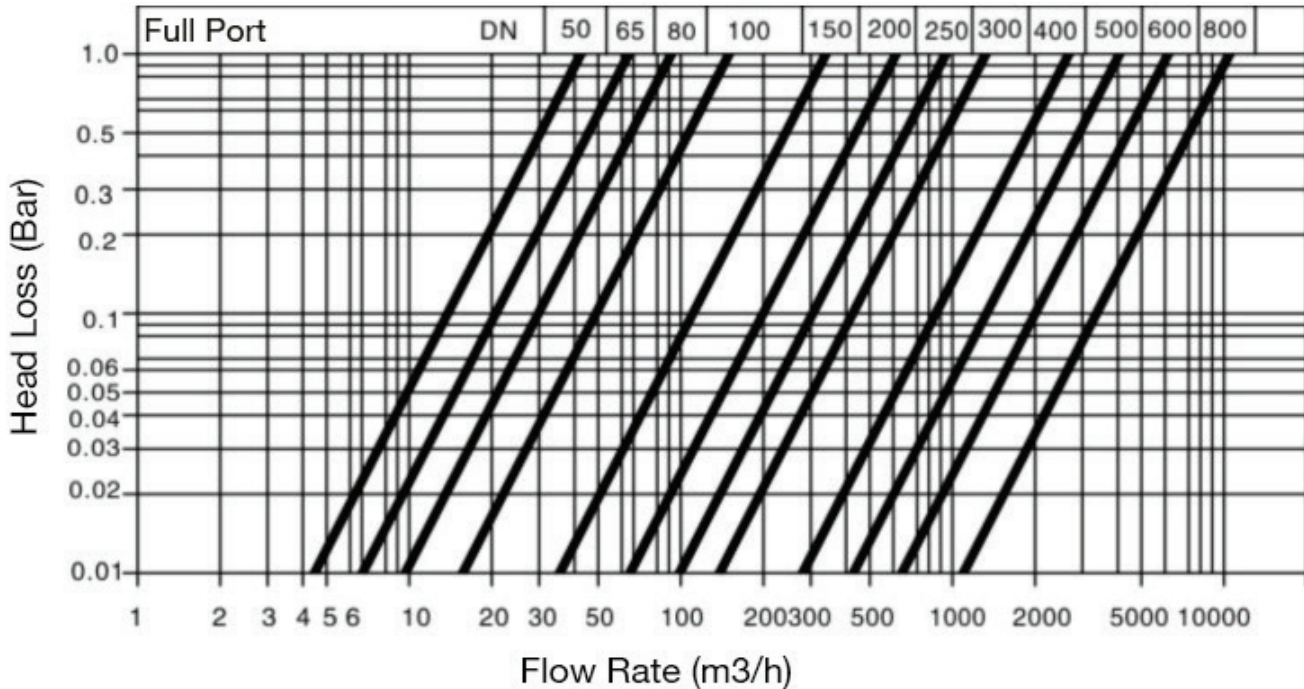

Dimensions in mm

This data sheet is designed as a guide and should not be regarded as wholly accurate in every detail. We reserve the right to amend the specification of any product without notice.

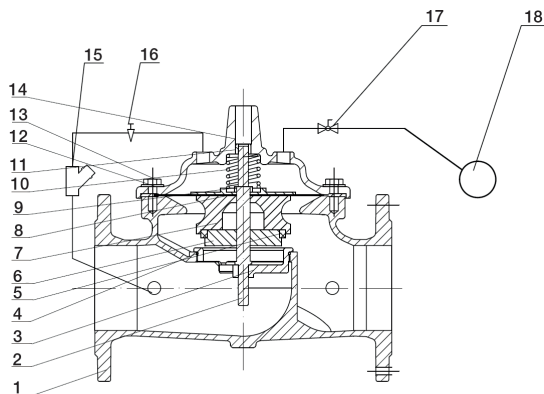
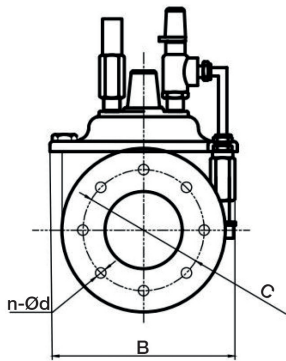
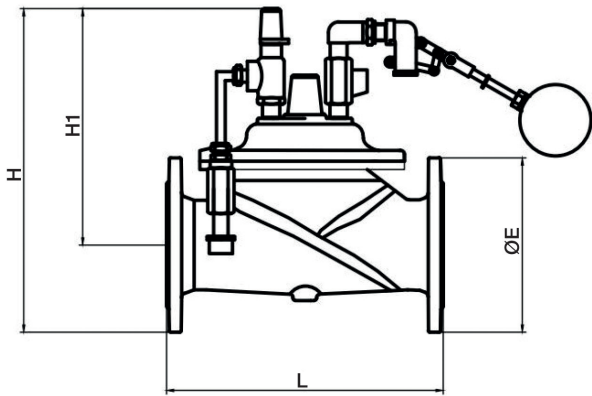

ANSI Float Control Valve

Features

- Automatic Control Valve
- Suitable for Potable Water Applications
- WRAS Approved Epoxy Coated Body
- Conforms to BS EN 558-1 Series 1
- Flange Conforms to ANSI 150 (B16.42)
- Available Flanged ANSI Class 300
- Stainless Steel Pilot Tubing and Valves
- Copper Float Option

Pressure/Temperature

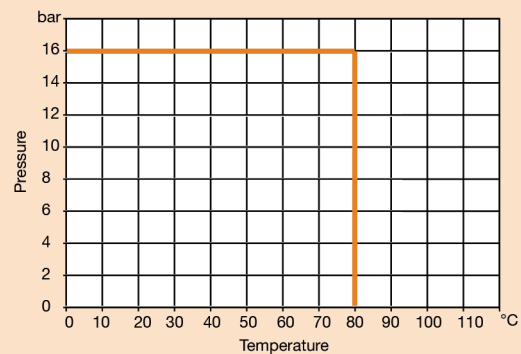

DN	50	65	80	100	125	150	200	250	300
L	230	290	310	350	400	480	600	730	850
E	152.4	177.8	190.5	228.6	254.0	279.4	342.9	406.4	482.6
C	120.7	139.7	152.4	190.5	215.9	241.3	298.5	362.0	431.8
n-d	4- Ø19	4- Ø19	4- Ø19	8- Ø19	8- Ø22.4	8- Ø22.4	8- Ø22.4	12- Ø25.4	12- Ø25.4
B	164	194	218	252	286	348	476	574	662
H	335	355	370	390	420	455	510	575	630
H1	242	252	270	280	295	313	340	372	400
Kgs	13	17	23	30	65	69	132	315	420

N.	Part Name	Materials
1	Body	Ductile Iron
2	Stem	Stainless Steel 304
3	Seat	Stainless Steel 304
4	O-Ring	NBR
5	Disc Ring	NBR
6	Disc Retailer	Ductile Iron
7	Disc Guide	Ductile Iron
8	Diaphragm	EPDM
9	Diaphragm Washer	Ductile Iron
10	Spring	Stainless Steel 304
11	Cover Bearing	Stainless Steel 304
12	Screw	Stainless Steel 304
13	Washer	Stainless Steel 304
14	Cover	Ductile Iron
15	Strainer	Stainless Steel 304
16	Needle Valve	Stainless Steel 304
17	Ball Valve	Stainless Steel 304
18	Float Control Valve	Stainless Steel 304

Technical Data

Max Pressure	16 Bar
Minimum Differential Pressure	5PSI (0.035MPa)
Working Temperature	0°C to +80°C

Dimensions in mm

This data sheet is designed as a guide and should not be regarded as wholly accurate in every detail. We reserve the right to amend the specification of any product without notice.

Pilot Valve Detail - ART 6150

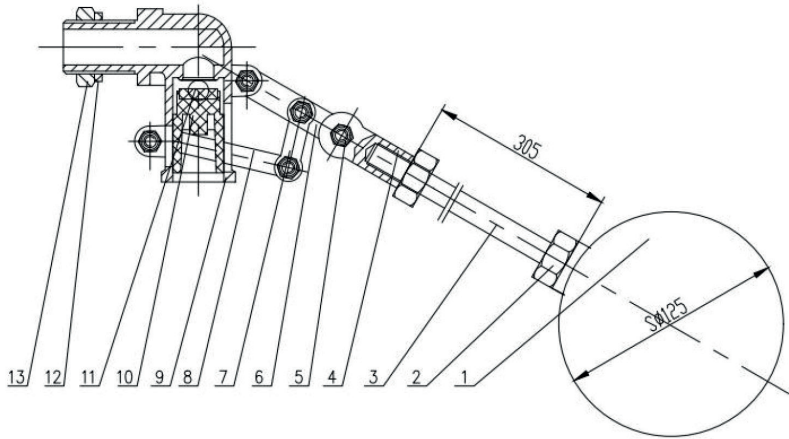

Pilot Valve

N.	Part Name	Materials
1	Float Ball	Stainless Steel 304
2	Nut	Stainless Steel 304
3	Rod	Stainless Steel 304
4	Level Holder	Stainless Steel 304
5	Screw / Nut	Stainless Steel 304
6	Arm	Stainless Steel 304
7	Level	Stainless Steel 304
8	Seat Holder	Stainless Steel 304
9	Body	Stainless Steel 304
10	Yoke	Stainless Steel 304
11	Seat	NBR
12	Washer	NBR
13	Nut	Stainless Steel 304

Flow curve of the main valve at fully open status

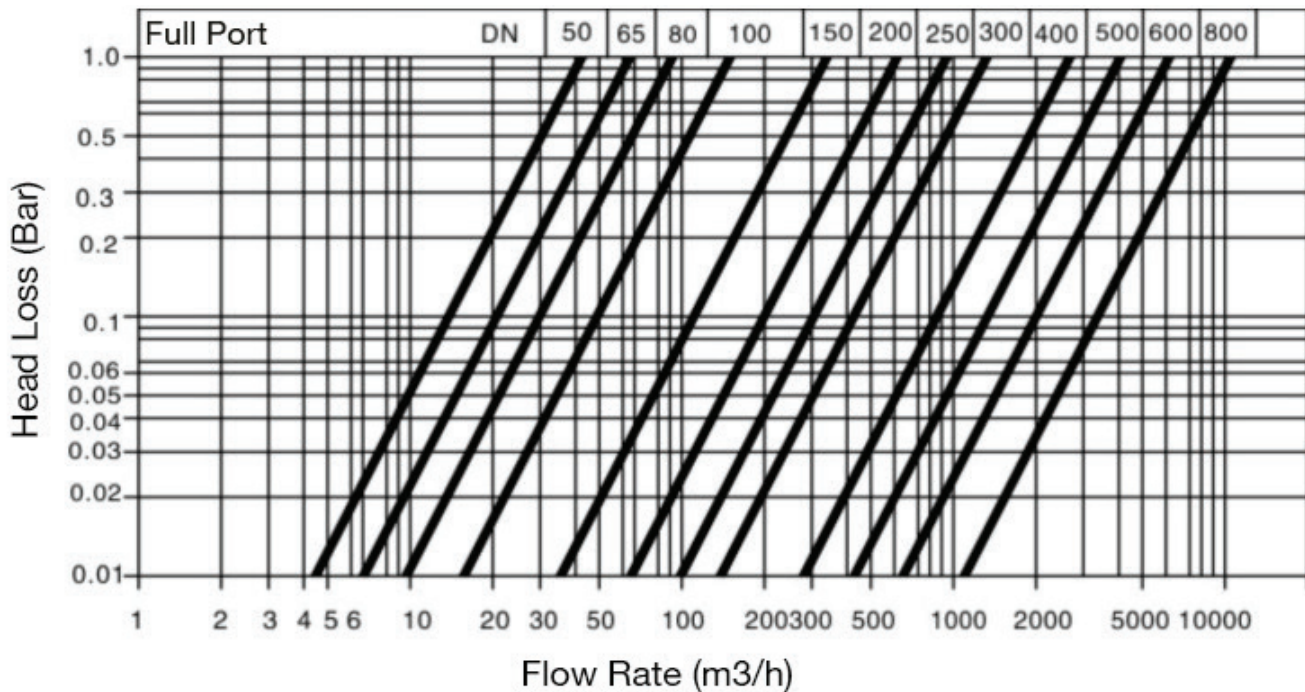

Dimensions in mm

This data sheet is designed as a guide and should not be regarded as wholly accurate in every detail. We reserve the right to amend the specification of any product without notice.

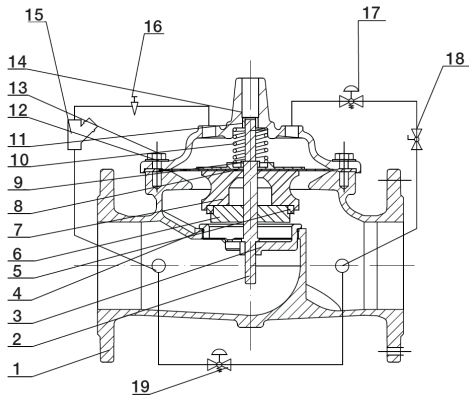
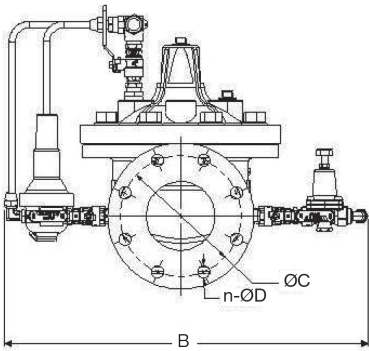
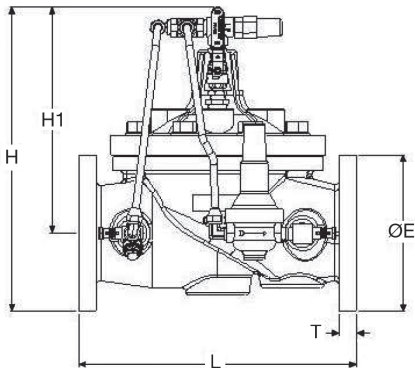

PN16 Adjustable Pressure Reducing Valve with Low Flow Bypass

Features

- Automatic Control Valve
- Suitable for potable water applications
- WRAS approved epoxy coated body
- Pressure adjusted by Integral Pilot Valve
- Conforms to BS EN 558-1 Series 1
- Flange conforms to BS EN 1092 PN16
- Available flanged PN25
- Stainless Steel Pilot Tubing and Valves

Pressure/Temperature

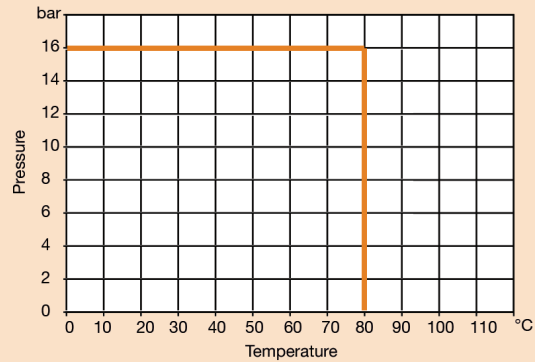

DN	50	65	80	100	125	150	200	250	300
L	230	290	310	350	400	480	600	730	850
E	165	185	200	220	250	285	340	405	460
C	125	145	160	180	210	240	295	355	410
n-d	4-Ø19	4-Ø19	8-Ø19	8-Ø19	8-Ø19	8-Ø23	12-Ø23	12-Ø28	12-Ø28
B	365	375	383	393	405	422	448	478	605
H	482	505	520	540	570	605	660	725	780
H1	350	413	420	430	445	463	490	523	550
Kgs	13	17	23	30	65	69	132	315	420

N.	Part Name	Materials
1	Body	Ductile Iron
2	Stem	Stainless Steel 304
3	Seat	Stainless Steel 304
4	O-Ring	NBR
5	Disc Ring	NBR
6	Disc Retailer	Ductile Iron
7	Disc Guide	Ductile Iron
8	Diaphragm	EPDM
9	Diaphragm Washer	Ductile Iron
10	Spring	Stainless Steel 304
11	Cover Bearing	Stainless Steel 304
12	Screw	Stainless Steel 304
13	Washer	Stainless Steel 304
14	Cover	Ductile Iron
15	Strainer	Stainless Steel 304
16	Needle Valve	Stainless Steel 304
17	Pilot Valve	Stainless Steel 304
18	Ball Valve	Stainless Steel 304
19	Low Bypass Pilot Valve	Stainless Steel 304

Technical Data

Max Pressure	16 Bar
Working Temperature	0°C to +80°C

Dimensions in mm

This data sheet is designed as a guide and should not be regarded as wholly accurate in every detail. We reserve the right to amend the specification of any product without notice.

Pilot Valve Detail - ART 6250

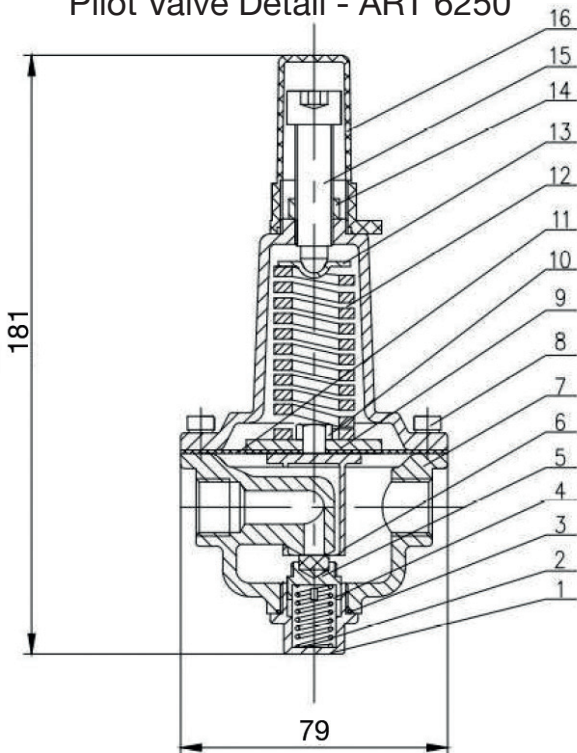

Fitted with Standard Pilot Valve
2.10 to 20.00 Bar (30 to 300 PSI)
Factory set to 5.50 Bar (80 PSI)

Low Flow Bypass Range
1.37 to 12.00 Bar (20 to 175 PSI)

Pilot Valve

N.	Part Name	Materials
1	Plug	Stainless Steel 304
2	Spring	Stainless Steel 304
3	O-Ring	NBR
4	Seat	Stainless Steel 304
5	Disc	NBR
6	Yoke	Stainless Steel 304
7	Body	Stainless Steel 304
8	Screw	Stainless Steel 304
9	Diaphragm Washer	Stainless Steel 304
10	Nut	Stainless Steel 304
11	Diaphragm	EPDM
12	Spring	Stainless Steel 304
13	Spring Holder	Stainless Steel 304
14	Locking Nut	Stainless Steel 304
15	Adjusting Screw	Stainless Steel 304
16	Cap	ABS

Operation Cavitation Chart

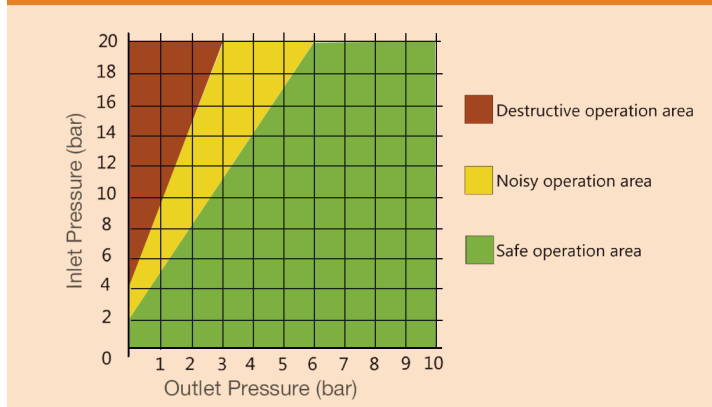

Flow curve of the main valve at fully open status

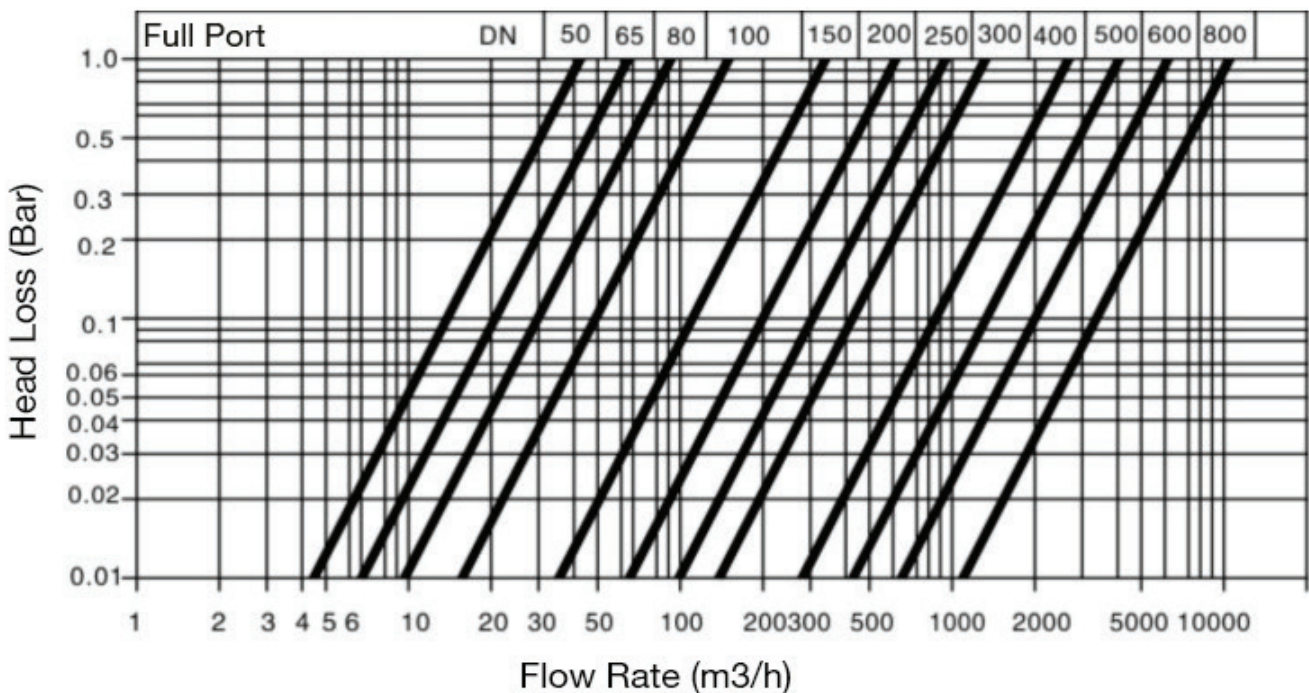

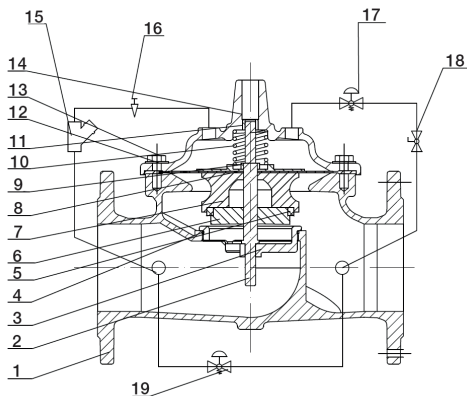
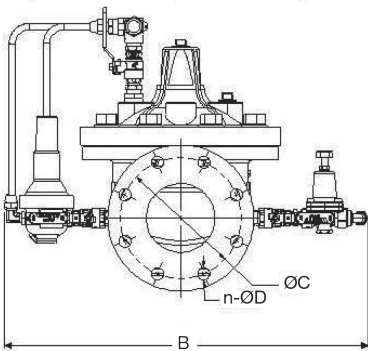
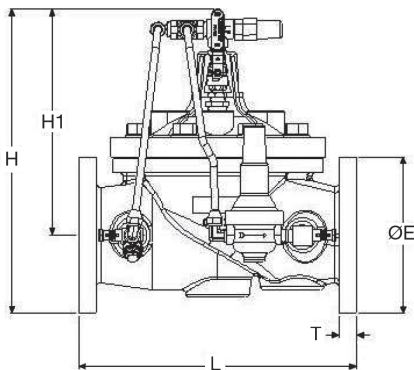

ANSI Adjustable Pressure Reducing Valve with Low Flow Bypass

Features

- Automatic Control Valve
- Suitable for potable water applications
- WRAS approved epoxy coated body
- Pressure adjusted by Integral Pilot Valve
- Conforms to BS EN 558-1 Series 1
- Flange conforms to ANSI 150 (B16.42)
- Available Flanged ANSI Class 300
- Stainless Steel Pilot Tubing and Valves

Pressure/Temperature

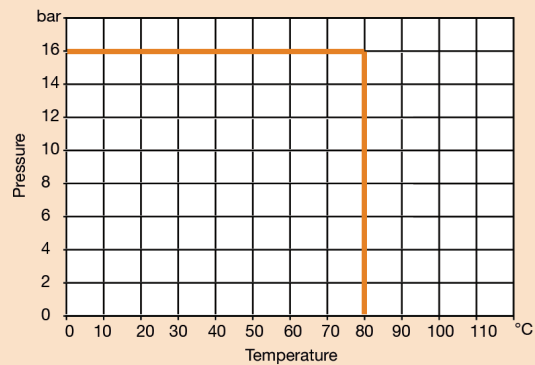

DN	50	65	80	100	125	150	200	250	300
L	230	290	310	350	400	480	600	730	850
E	152.4	177.8	190.5	228.6	254.0	279.4	342.9	406.4	482.6
C	120.7	139.7	152.4	190.5	215.9	241.3	298.5	362.0	431.8
n-d	4- Ø19	4- Ø19	4- Ø19	8- Ø19	8- Ø22.4	8- Ø22.4	8- Ø22.4	12- Ø25.4	12- Ø25.4
B	365	375	383	393	405	422	448	478	605
H	482	505	520	540	570	605	660	725	780
H1	350	413	420	430	445	463	490	523	550
Kgs	13	17	23	30	65	69	132	315	420

N.	Part Name	Materials
1	Body	Ductile Iron
2	Stem	Stainless Steel 304
3	Seat	Stainless Steel 304
4	O-Ring	NBR
5	Disc Ring	NBR
6	Disc Retailer	Ductile Iron
7	Disc Guide	Ductile Iron
8	Diaphragm	EPDM
9	Diaphragm Washer	Ductile Iron
10	Spring	Stainless Steel 304
11	Cover Bearing	Stainless Steel 304
12	Screw	Stainless Steel 304
13	Washer	Stainless Steel 304
14	Cover	Ductile Iron
15	Strainer	Stainless Steel 304
16	Needle Valve	Stainless Steel 304
17	Pilot Valve	Stainless Steel 304
18	Ball Valve	Stainless Steel 304
19	Low Bypass Pilot Valve	Stainless Steel 304

Technical Data

Max Pressure	16 Bar
Working Temperature	0°C to +80°C

Dimensions in mm

This data sheet is designed as a guide and should not be regarded as wholly accurate in every detail. We reserve the right to amend the specification of any product without notice.

Pilot Valve Detail - ART 6250

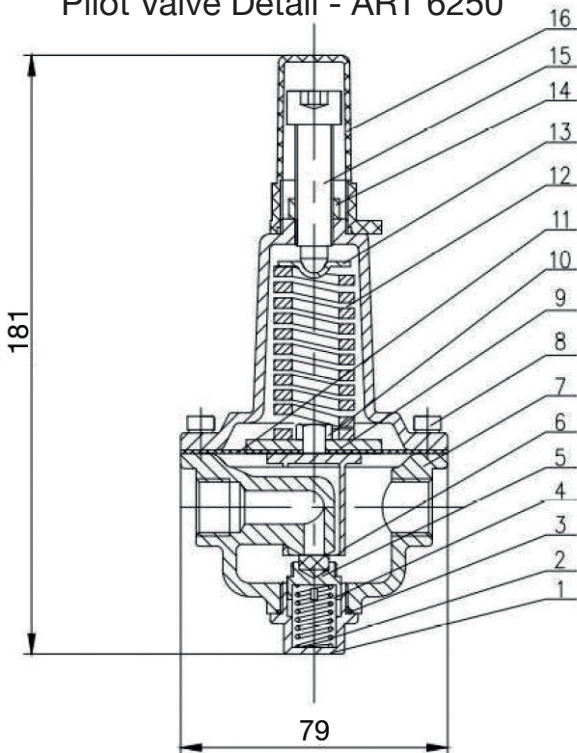

Fitted with Standard Pilot Valve
2.10 to 20.00 Bar (30 to 300 PSI)
Factory set to 5.50 Bar (80 PSI)

Low Flow Bypass Range
1.37 to 12.00 Bar (20 to 175 PSI)

Pilot Valve

N.	Part Name	Materials
1	Plug	Stainless Steel 304
2	Spring	Stainless Steel 304
3	O-Ring	NBR
4	Seat	Stainless Steel 304
5	Disc	NBR
6	Yoke	Stainless Steel 304
7	Body	Stainless Steel 304
8	Screw	Stainless Steel 304
9	Diaphragm Washer	Stainless Steel 304
10	Nut	Stainless Steel 304
11	Diaphragm	EPDM
12	Spring	Stainless Steel 304
13	Spring Holder	Stainless Steel 304
14	Locking Nut	Stainless Steel 304
15	Adjusting Screw	Stainless Steel 304
16	Cap	ABS

Operation Cavitation Chart

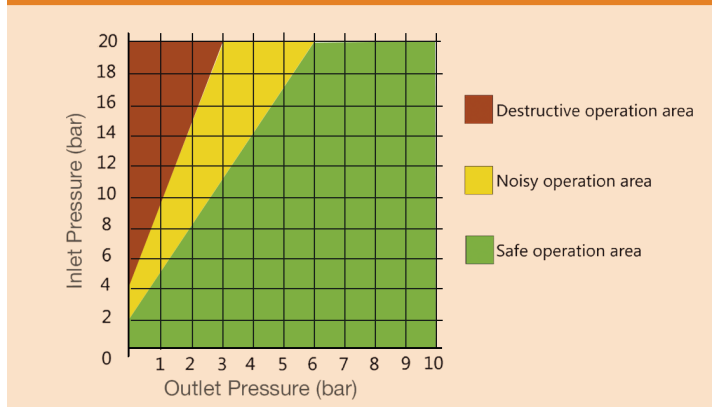

Flow curve of the main valve at fully open status

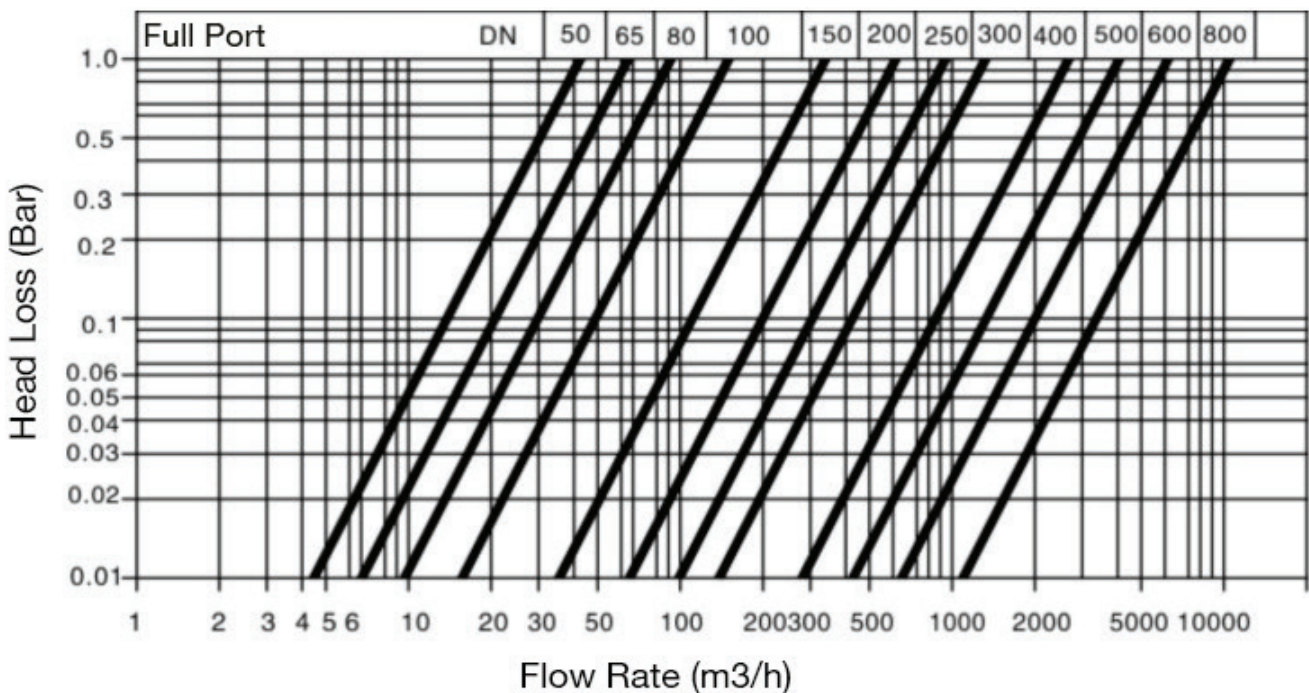

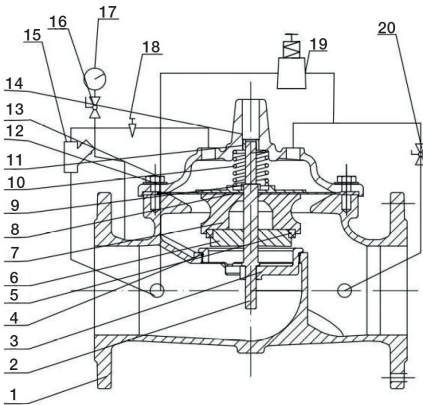
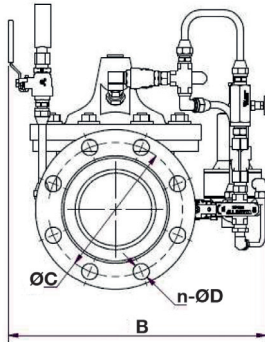
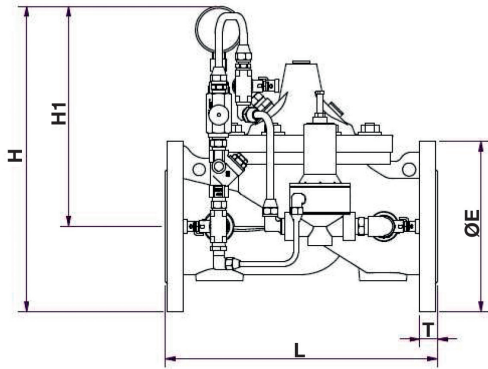

PN16 Adjustable Pressure Relief / Sustaining Valve

Features

- Automatic Control Valve
- Suitable for potable water applications
- WRAS approved epoxy coated body
- Pressure adjusted by Integral Pilot Valve
- Conforms to BS EN 558-1 Series 1
- Flange conforms to BS EN 1092 PN16
- Available flanged PN25
- Stainless steel pilot tubing and valves

Pressure/Temperature

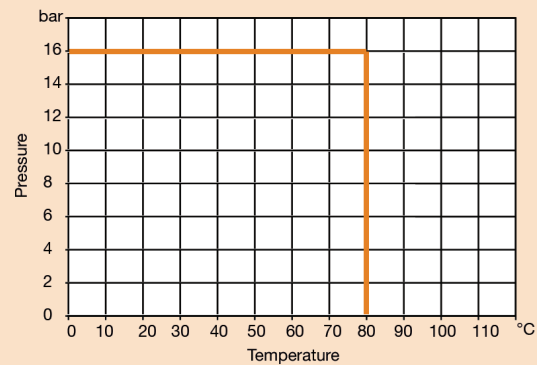

DN	50	65	80	100	125	150	200	250	300
L	230	290	310	350	400	480	600	730	850
E	165	185	200	220	250	285	340	405	460
C	125	145	160	180	210	240	295	355	410
n-d	4-Ø19	4-Ø19	8-Ø19	8-Ø19	8-Ø19	8-Ø23	12-Ø23	12-Ø28	12-Ø28
B	270	290	305	325	355	390	435	500	565
H	485	505	520	540	570	605	660	725	780
H1	402	412	420	430	445	463	491	523	651
Kgs	13	17	23	30	65	69	132	315	420

N.	Part Name	Materials
1	Body	Ductile Iron
2	Stem	Stainless Steel 304
3	Seat	Stainless Steel 304
4	O-Ring	NBR
5	Disc Ring	NBR
6	Disc Retailer	Ductile Iron
7	Disc Guide	Ductile Iron
8	Diaphragm	EPDM
9	Diaphragm Washer	Ductile Iron
10	Spring	Stainless Steel 304
11	Cover Bearing	Stainless Steel 304
12	Screw	Stainless Steel 304
13	Washer	Stainless Steel 304
14	Cover	Ductile Iron
15	Strainer	Stainless Steel 304
16	Ball Valve	Stainless Steel 304
17	Gauge	Stainless Steel 304
18	Needle Valve	Stainless Steel 304
19	Pilot Valve	Stainless Steel 304
20	Ball Valve	Stainless Steel 304

Technical Data

Max Pressure	16 Bar
Working Temperature	0°C to +80°C

Dimensions in mm

This data sheet is designed as a guide and should not be regarded as wholly accurate in every detail. We reserve the right to amend the specification of any product without notice.

Pilot Valve Detail - ART 6550

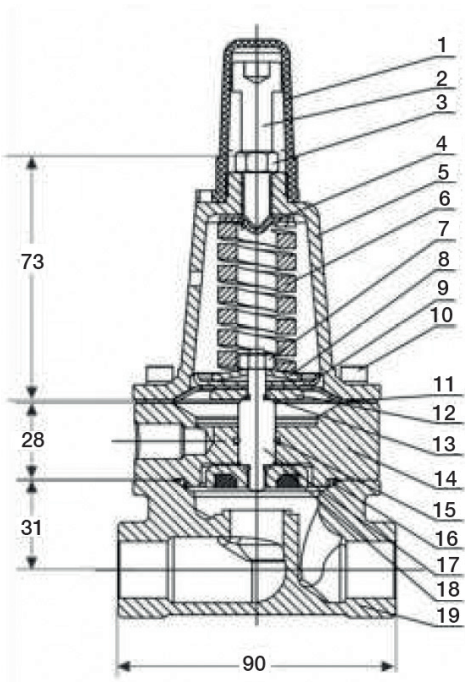

Pilot Valve

N.	Part Name	Materials
1	Cap	ABS
2	Adjusting Screw	Stainless Steel 304
3	Locking Nut	Stainless Steel 304
4	Upper Spring Holder	Stainless Steel 304
5	Cover	Stainless Steel 304
6	Spring	Stainless Steel 304
7	Nut	Stainless Steel 304
8	Lower Spring Holder	Stainless Steel 304
9	Diaphragm Washer	Stainless Steel 304
10	Screw	Stainless Steel 304
11	Diaphragm	EPDM
12	Disc Holder	Stainless Steel 304
13	O-Ring	NBR
14	Guide	Stainless Steel 304
15	O-Ring	NBR
16	O-Ring	NBR
17	Stem	Stainless Steel 304
18	Disc	Stainless Steel 304 + NBR
19	Body	Stainless Steel 304

Fitted with standard Pilot Valve
0.70 to 12.00 Bar (10 to 175 PSI)

Flow curve of the main valve at fully open status

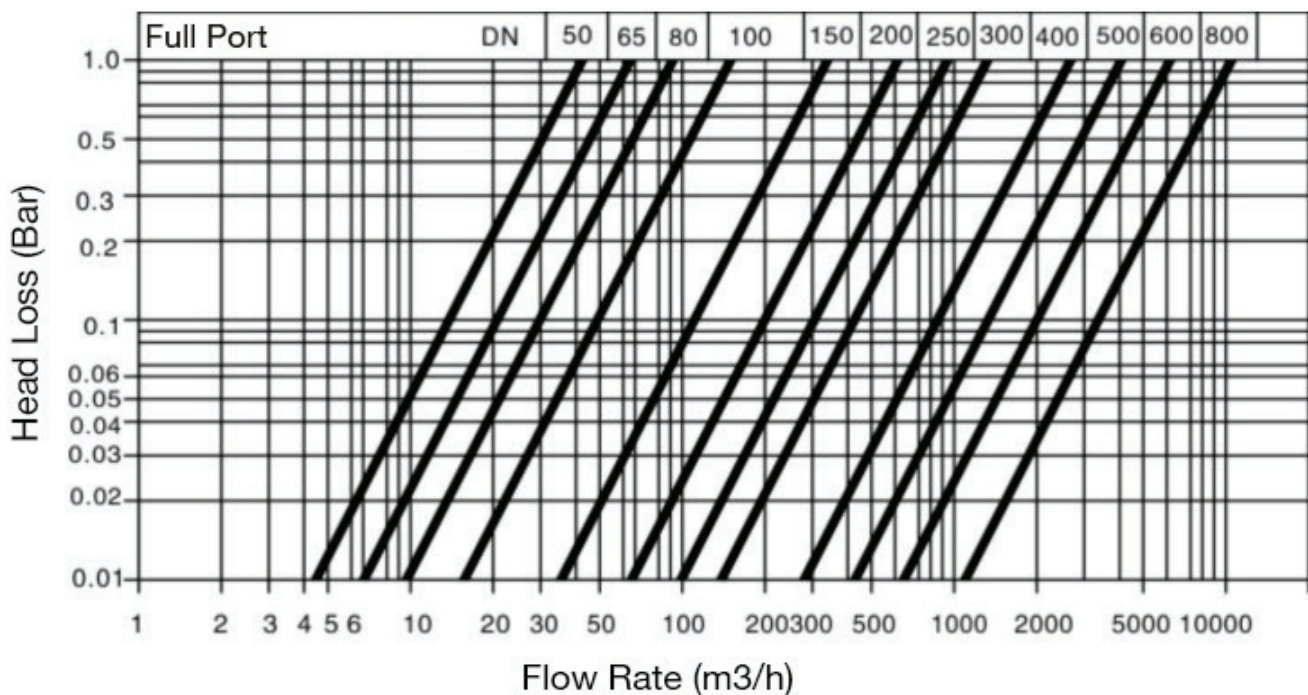

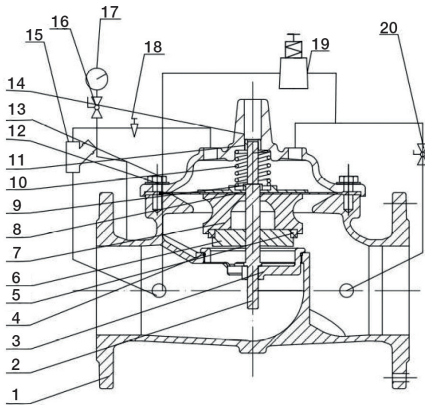
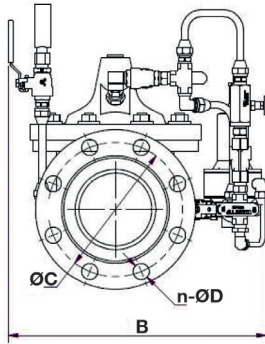
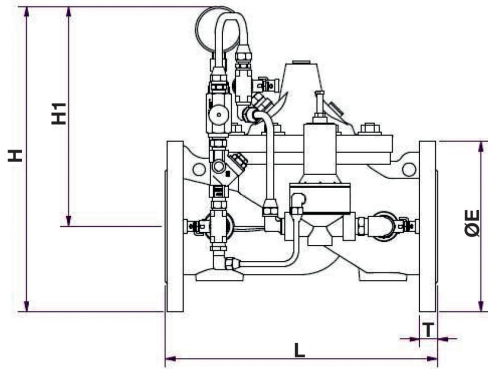

ANSI Adjustable Pressure Relief / Sustaining Valve

Features

- Automatic Control Valve
- Suitable for potable water applications
- WRAS approved epoxy coated body
- Pressure adjusted by Integral Pilot Valve
- Conforms to BS EN 558-1 Series 1
- Flange conforms to ANSI 150 (B16.42)
- Available Flanged ANSI Class 300
- Stainless steel pilot tubing and valves

Pressure/Temperature

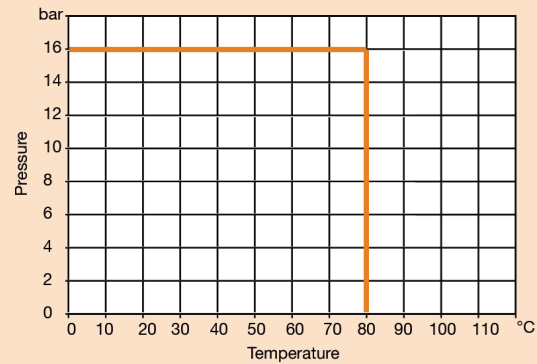

DN	50	65	80	100	125	150	200	250	300
L	230	290	310	350	400	480	600	730	850
E	152.4	177.8	190.5	228.6	254.0	279.4	342.9	406.4	482.6
C	120.7	139.7	152.4	190.5	215.9	241.3	298.5	362.0	431.8
n-d	4- Ø19	4- Ø19	4- Ø19	8- Ø19	8- Ø22.4	8- Ø22.4	8- Ø22.4	12- Ø25.4	12- Ø25.4
B	270	290	305	325	355	390	435	500	565
H	485	505	520	540	570	605	660	725	780
H1	402	412	420	430	445	463	491	523	651
Kgs	13	17	23	30	65	69	132	315	420

N.	Part Name	Materials
1	Body	Ductile Iron
2	Stem	Stainless Steel 304
3	Seat	Stainless Steel 304
4	O-Ring	NBR
5	Disc Ring	NBR
6	Disc Retailer	Ductile Iron
7	Disc Guide	Ductile Iron
8	Diaphragm	EPDM
9	Diaphragm Washer	Ductile Iron
10	Spring	Stainless Steel 304
11	Cover Bearing	Stainless Steel 304
12	Screw	Stainless Steel 304
13	Washer	Stainless Steel 304
14	Cover	Ductile Iron
15	Strainer	Stainless Steel 304
16	Ball Valve	Stainless Steel 304
17	Gauge	Stainless Steel 304
18	Needle Valve	Stainless Steel 304
19	Pilot Valve	Stainless Steel 304
20	Ball Valve	Stainless Steel 304

Technical Data

Max Pressure	16 Bar
Working Temperature	0°C to +80°C

Dimensions in mm

This data sheet is designed as a guide and should not be regarded as wholly accurate in every detail. We reserve the right to amend the specification of any product without notice.

Pilot Valve Detail - ART 6550

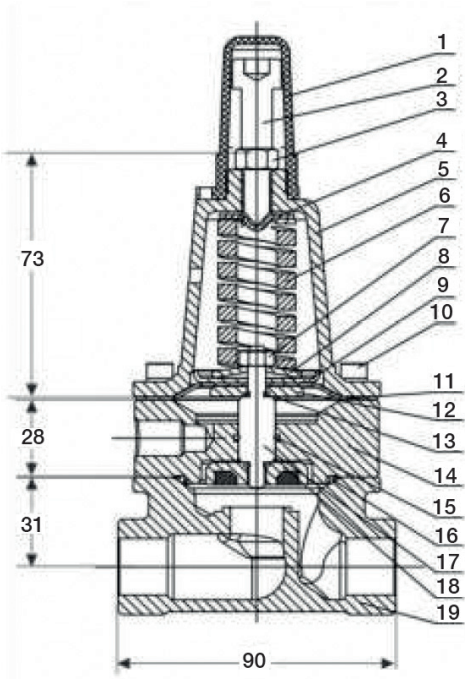

Pilot Valve

N.	Part Name	Materials
1	Cap	ABS
2	Adjusting Screw	Stainless Steel 304
3	Locking Nut	Stainless Steel 304
4	Upper Spring Holder	Stainless Steel 304
5	Cover	Stainless Steel 304
6	Spring	Stainless Steel 304
7	Nut	Stainless Steel 304
8	Lower Spring Holder	Stainless Steel 304
9	Diaphragm Washer	Stainless Steel 304
10	Screw	Stainless Steel 304
11	Diaphragm	EPDM
12	Disc Holder	Stainless Steel 304
13	O-Ring	NBR
14	Guide	Stainless Steel 304
15	O-Ring	NBR
16	O-Ring	NBR
17	Stem	Stainless Steel 304
18	Disc	Stainless Steel 304 + NBR
19	Body	Stainless Steel 304

Fitted with standard Pilot Valve
0.70 to 12.00 Bar (10 to 175 PSI)

Flow curve of the main valve at fully open status

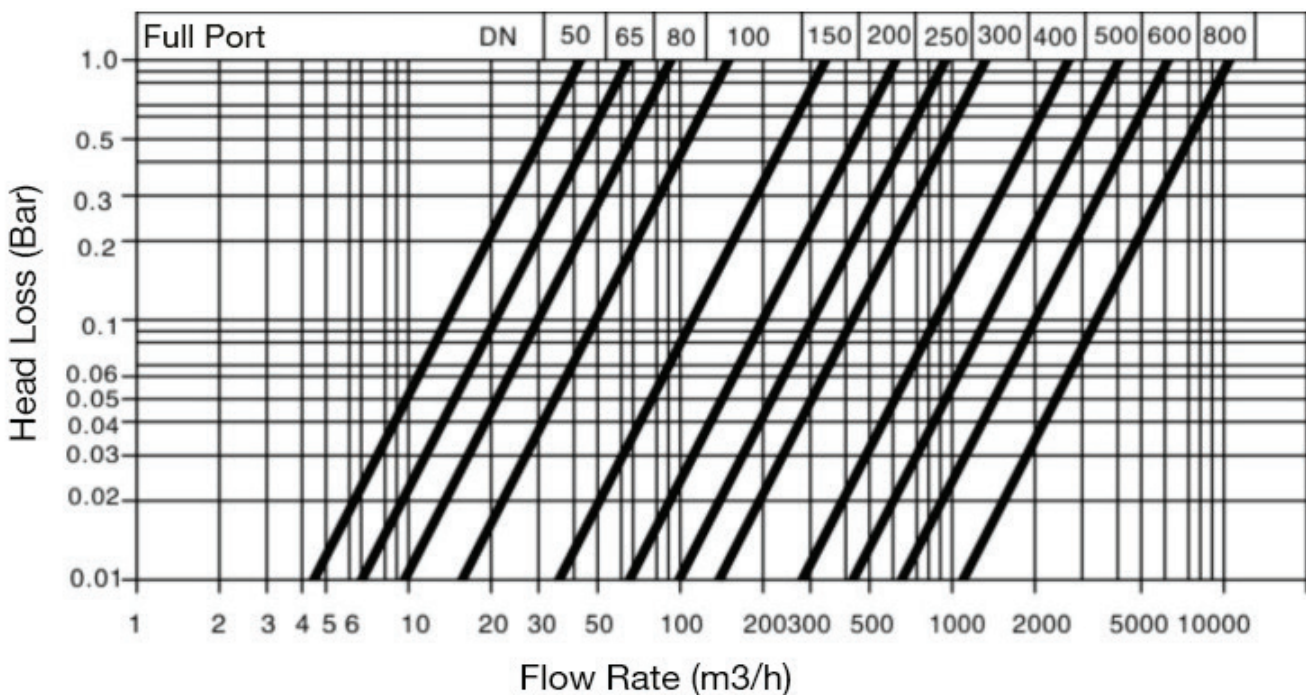

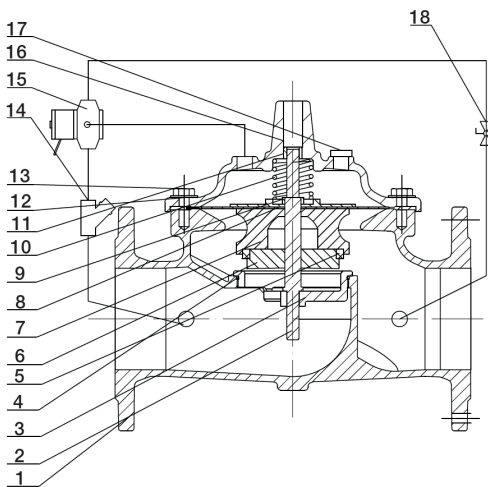
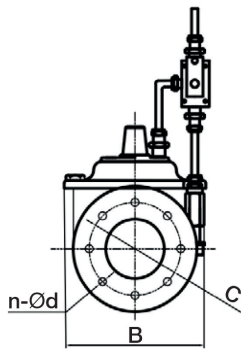
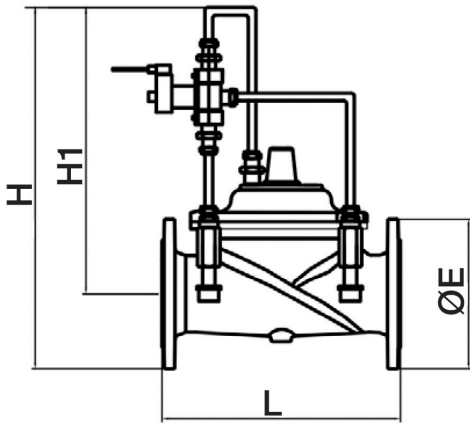

PN16 Solenoid On/Off Control Valve

Features

- Automatic Control Valve
- Suitable for Potable Water Applications
- WRAS Approved Epoxy Coated Body
- Conforms to BS EN 558-1 Series 1
- Flange Conforms to BS EN 1092 PN16
- Available Flanged PN25
- Stainless Steel Pilot Tubing and Valves, Brass Pilot Solenoid Valve
- Normally Closed and Normally Open Option

Pressure/Temperature

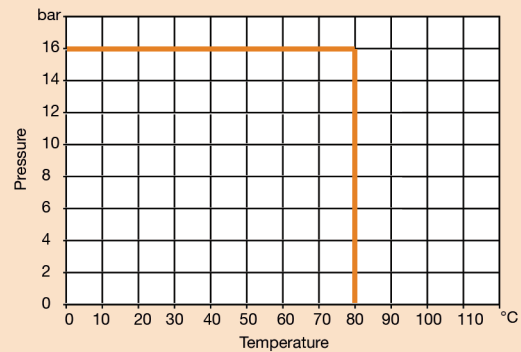

DN	50	65	80	100	125	150	200	250	300
L	230	290	310	350	400	480	600	730	850
E	165	185	200	220	250	285	340	405	460
C	125	145	160	180	210	240	295	355	410
n-d	4- Ø19	4- Ø19	8- Ø19	8- Ø19	8- Ø19	8- Ø23	12- Ø23	12- Ø28	12- Ø28
B	265	300	310	320	350	385	440	505	560
H	365	385	400	420	450	485	540	605	660
H1	282	293	300	310	325	342	370	402	430
Kgs	12.0	16.0	22.0	29.0	64.0	68.0	131.0	314.0	418.0

N.	Part Name	Materials
1	Body	Ductile Iron
2	Stem	Stainless Steel 304
3	Seat	Stainless Steel 304
4	O-Ring	NBR
5	Disc Ring	NBR
6	Disc Retailer	Ductile Iron
7	Disc Guide	Ductile Iron
8	Diaphragm	EPDM
9	Diaphragm Washer	Ductile Iron
10	Spring	Stainless Steel 304
11	Cover Bearing	Stainless Steel 304
12	Screw	Stainless Steel 304
13	Washer	Stainless Steel 304
14	Strainer	Stainless Steel 304
15	Solenoid Valve	Brass
16	Cover	Stainless Steel 304
17	Plug	Stainless Steel 304
18	Ball Valve	Stainless Steel 304

Technical Data

Max Pressure	16 Bar
Working Temperature	0°C to +80°C

Dimensions in mm

This data sheet is designed as a guide and should not be regarded as wholly accurate in every detail. We reserve the right to amend the specification of any product without notice.

Pilot Valve Detail - ART 6650 NC / ART 6675 NO

Pilot Valve

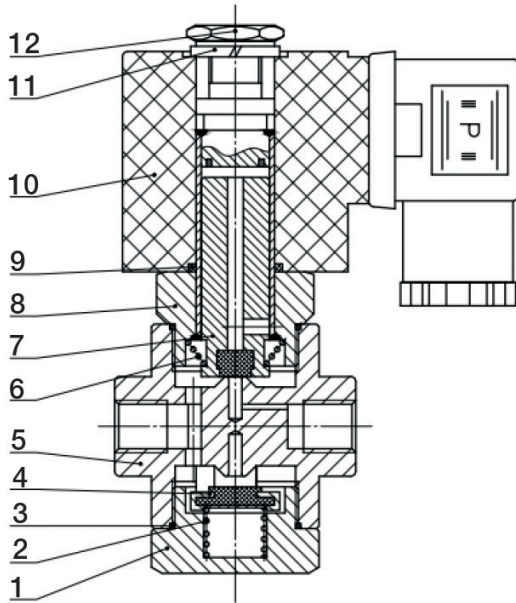

N.	Part Name	Materials
1	Nut	HPb59-1
2	Spring	Stainless Steel 304
3	O-Ring	NBR
4	Part Sub-assembly	ABS
5	Body	HPB59-1
6	Spring	Stainless Steel 304
7	Part Sub-assembly	ABS + NBR
8	Part Sub-assembly	ABS + NBR
9	O-Ring	NBR
10	Coil	Copper + PVF
11	Gasket	65Mn
12	Nut	A3

Flow curve of the main valve at fully open status

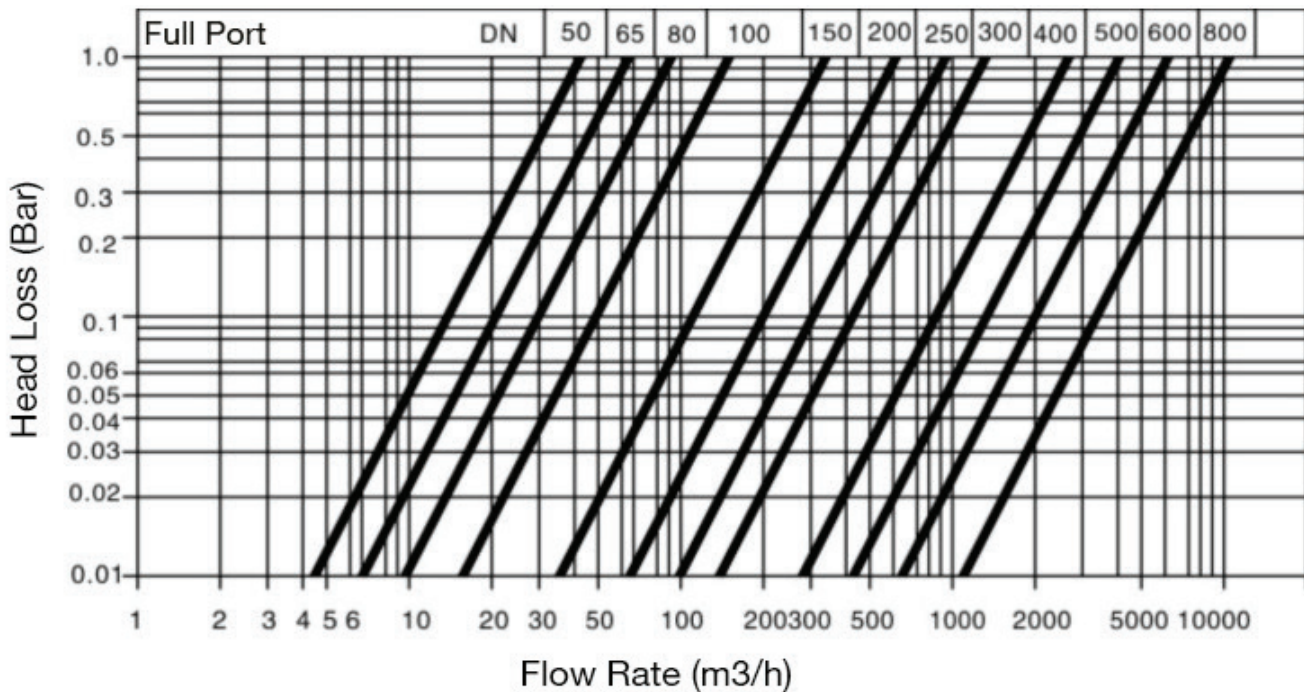

Dimensions in mm

This data sheet is designed as a guide and should not be regarded as wholly accurate in every detail. We reserve the right to amend the specification of any product without notice.

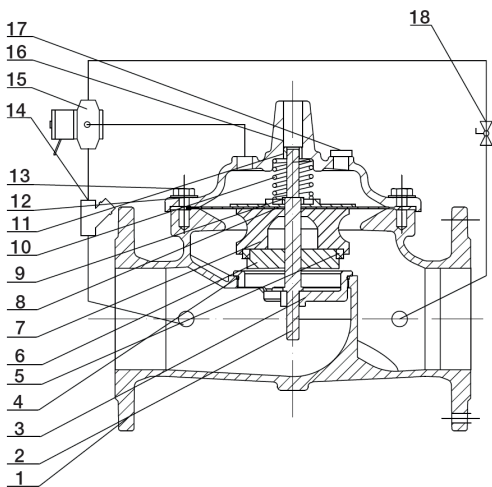
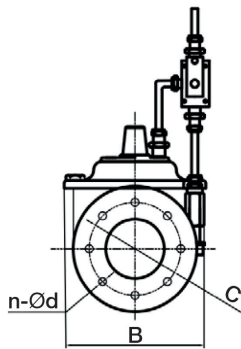
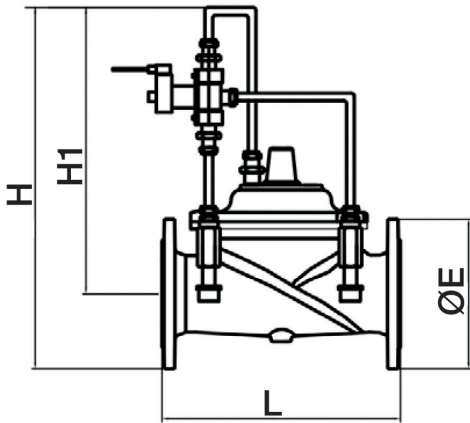

ANSI Solenoid On/Off Control Valve

Features

- Automatic Control Valve
- Suitable for Potable Water Applications
- WRAS Approved Epoxy Coated Body
- Conforms to BS EN 558-1 Series 1
- Flange Conforms to ANSI 150 (B16.42)
- Available Flanged ANSI Class 300
- Stainless Steel Pilot Tubing and Valves, Brass Pilot Solenoid Valve
- Normally Closed and Normally Open Option

Pressure/Temperature

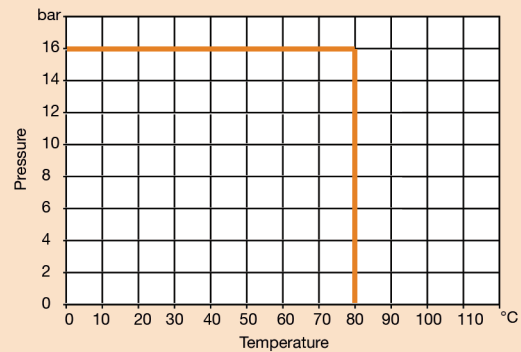

DN	50	65	80	100	125	150	200	250	300
L	230	290	310	350	400	480	600	730	850
E	152.4	177.8	190.5	228.6	254.0	279.4	342.9	406.4	482.6
C	120.7	139.7	152.4	190.5	215.9	241.3	298.5	362.0	431.8
n-d	4- Ø19	4- Ø19	4- Ø19	8- Ø19	8- Ø22.4	8- Ø22.4	8- Ø22.4	12- Ø25.4	12- Ø25.4
B	265	300	310	320	350	385	440	505	560
H	365	385	400	420	450	485	540	605	660
H1	282	293	300	310	325	342	370	402	430
Kgs	12.0	16.0	22.0	29.0	64.0	68.0	131.0	314.0	418.0

N.	Part Name	Materials
1	Body	Ductile Iron
2	Stem	Stainless Steel 304
3	Seat	Stainless Steel 304
4	O-Ring	NBR
5	Disc Ring	NBR
6	Disc Retailer	Ductile Iron
7	Disc Guide	Ductile Iron
8	Diaphragm	EPDM
9	Diaphragm Washer	Ductile Iron
10	Spring	Stainless Steel 304
11	Cover Bearing	Stainless Steel 304
12	Screw	Stainless Steel 304
13	Washer	Stainless Steel 304
14	Strainer	Stainless Steel 304
15	Solenoid Valve	Brass
16	Cover	Stainless Steel 304
17	Plug	Stainless Steel 304
18	Ball Valve	Stainless Steel 304

Technical Data

Max Pressure	16 Bar
Working Temperature	0°C to +80°C

Dimensions in mm

This data sheet is designed as a guide and should not be regarded as wholly accurate in every detail. We reserve the right to amend the specification of any product without notice.

Pilot Valve Detail - ART 6650 NC / ART 6675 NO

Pilot Valve

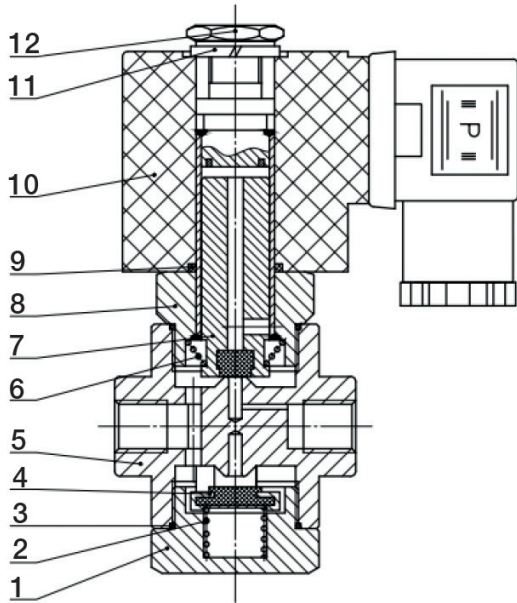

N.	Part Name	Materials
1	Nut	HPb59-1
2	Spring	Stainless Steel 304
3	O-Ring	NBR
4	Part Sub-assembly	ABS
5	Body	HPB59-1
6	Spring	Stainless Steel 304
7	Part Sub-assembly	ABS + NBR
8	Part Sub-assembly	ABS + NBR
9	O-Ring	NBR
10	Coil	Copper + PVF
11	Gasket	65Mn
12	Nut	A3

Flow curve of the main valve at fully open status

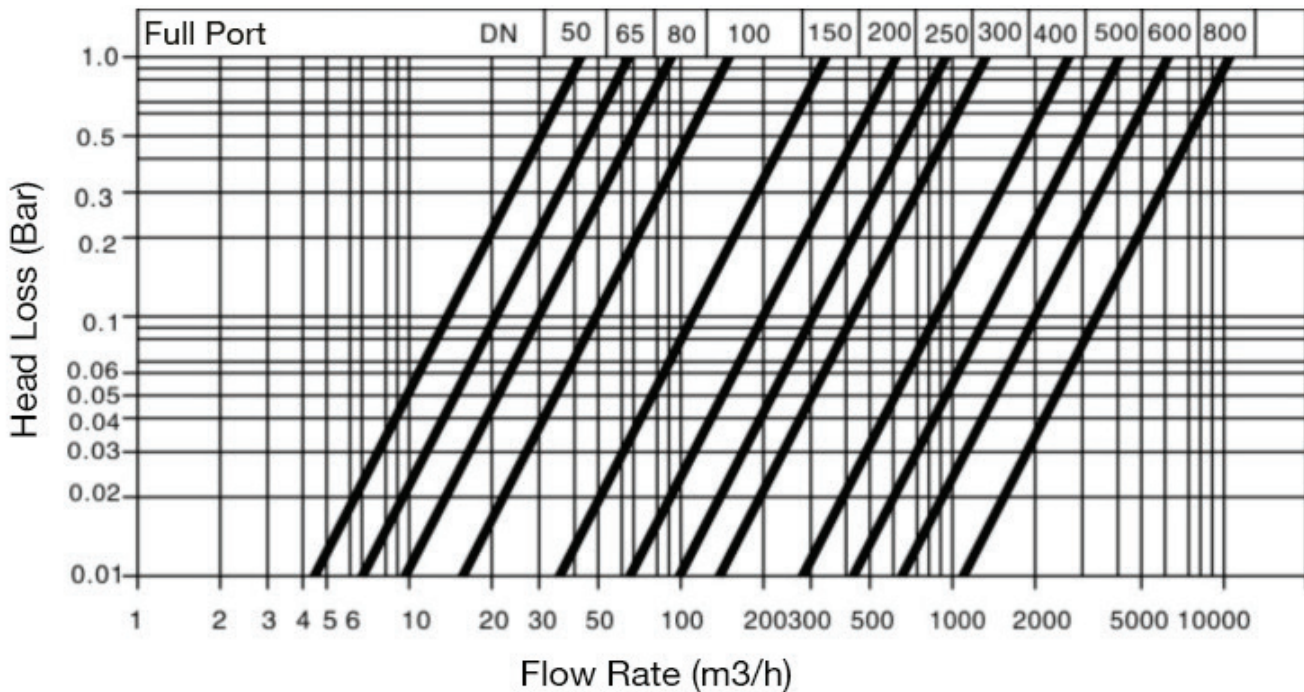

Dimensions in mm

This data sheet is designed as a guide and should not be regarded as wholly accurate in every detail. We reserve the right to amend the specification of any product without notice.

1. Safety

- Only use the valve;
 - for the intended purpose
 - in satisfactory condition
 - with respect for safety and potential hazards.
- Always observe the installation instructions;
- Faults that may impair safety must be addressed immediately;
- The valves are exclusively intended for the application area stated in these installation instructions. Any other or further use is not valid as the intended use;
- The manufacturer's warranty shall be null and void if the sealed cover is removed;
- All assembly work is to be carried out by authorised specialist staff.

2. General Notes

Safety valves are high-quality fittings which require a particularly careful handling.

The sealing surfaces are precision-machined at the seat and cone to attain the required tightness. Always avoid the penetration of foreign particles into the valve during assembly and during the operation. The tightness of a safety valve can be impaired when using hemp, PTFE tape and welding beads, amongst other things. Also rough handling of the finished valve during storage, transport and assembly can result in a safety valve leaking. If the safety valves are painted, make sure that the sliding parts do not come into contact with the paint.

3. Range of Application

For details on the range of application of the individual versions please refer to the datasheets of the manufacturer.

4. Installation and Assembly

Spring-loaded safety valves are to be installed with the spring bonnet pointing vertically upward in line with the direction of the arrow.

To ensure satisfactory operation of the safety valves they must be installed in such a way that the safety valve is not exposed to any impermissible static, dynamic or thermal loads.

Appropriate protection devices must be applied if the medium that discharges upon actuation of the valve can lead to direct or indirect hazards to people or the environment. Always pay attention to possible fumes discharging from the relief bores in the spring bonnet.

Supply

Supply connection pieces for safety valves are to be kept as short as possible and are to be designed in such a way that there can be no pressure loss greater than 3% (Max.) of the response pressure.

Removal of condensate discharge

In the event of possible condensation the pipes or the valves themselves must be fitted at their lowest point with a continuously operating condensate discharge device. Hazard-free removal of the condensate or medium discharge must be ensured. The body, pipes and silencers must be protected against freezing.

Blowing-off pipe / backpressure

The blow-off pipe of the safety valves must be designed to ensure that the required mass flow can be discharged pressure-free during the blowing-off process.

5. Operation/Maintenance

Safety valves are the ultimate safety device for the tank or system. They must be able to prevent impermissible overpressure even when all other upstream control and monitoring equipment fail. To ensure these characteristics safety valves require maintenance, just like any other technical device. The maintenance intervals are determined by the operator in depending upon the operating conditions.

The operating pressure of the plant is to be at least 5 % lower than the closing pressure of the safety valve. In this way, the valve can satisfactorily close again after blowing off. In the event of minor leaks, which may be caused by contamination between the sealing surfaces, the valve can be made to blow off through lifting, for cleaning purposes. If this does not remove the leak, the sealing surface is probably damaged and this can only be repaired at our factory or by authorised specialists. Lifting is by actuating the lifting lever on the upper part of the valve (Fig. a). For delivery purposes the lifting lever is tied by means of a strap which has to be removed for actuating the lifting device.

Prior to removal make sure that the safety valve is not under pressure.

Lifting for maintenance purposes

It is recommended and in some plant specific situations mandatory to manually "blow off" the valve by lifting the seal off the seat with the use of the lifting lever (fig a), in order to ensure correct functioning of the safety valve.

The line pressure must be $\geq 85\%$ of the set pressure before the lifting the lever. The lifting lever is NOT to be operated when the pressure is zero.

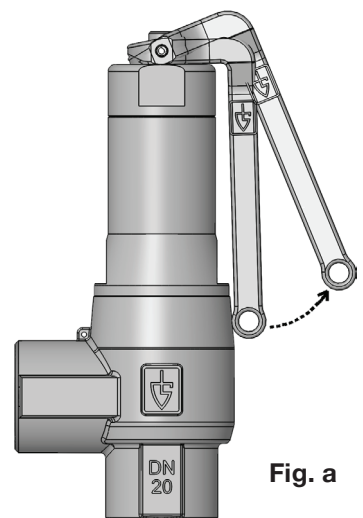

Fig. a

6. Dismantling the Fitting

In addition to the general installation instructions it must be ensured that the system is made pressure free prior to disassembly of the safety valve.

7. Repairs

Repair work on safety valves is only to be carried out by Goetze KG Armaturen or by officially approved specialist workshops authorised by Goetze KG Armaturen using original spare parts only.

8. Warranty

Every valve is tested prior to leaving the factory. We grant a warranty for our products which entails a free of charge repair of any parts that are returned and verified as being prematurely unsuitable for use due to defective material or manufacturing. We shall not assume any liability for any damage or other such obligations. If the seal is damaged due to any incorrect handling of or installation, non-observance of these operating and maintenance instructions, contamination or normal wear, warranty claims shall be null and void.

9. Marking/Testing

Type Description

EN ISO 4126-1

Set Pressure p [bar]

Narrowest cross-section of flow: A [mm²]

Reduced Discharge Ratio: S/G k_{dr} designed for steam/gas
L k_{dr} designed for liquids

Lift (at 10% above set pressure) h [mm]

We check the safety valves for pressure resistance and tightness, adjust the requested set pressure and seal them.

The identification on the type plate or on the spring bonnet of the valve is applied using a permanent marking system.

In addition markings and technical data according to DIN EN ISO 4126-1 are included on the identification plate.

10. Declaration of Conformity

According to Annex VII of the Directive 97/23/EC

We, **Goetze KG Armaturen, D-71636 Ludwigsburg** declare under sole responsibility that the delivered product:

Safety valve

Series EC type test

642 ✓

645 ✓

has been manufactured in compliance with the Directive 97/23/EC and DIN ISO4126 and was subjected to the conformity assessment procedure:

Module B+D

An EC type test certificate is available for the equipment part for pressure devices.

The manufacturer produces the safety valves on behalf of Albion Valves UK Limited under the trademark "Albion".

The monitoring of the production quality assurance is performed by TÜV SÜD Industrie Service GmbH (0036).

Ludwigsburg, 30.04.2013

(Place and date of issue)



D. Weimann
Management

AVION



Certificate No. 1437B



Certificate No. 1437A

Distributor