

PN16 Cast Iron Swing Check Valve, Lever & Weight



Features

- Flange Mounting PN16 Only
- Flange conforms to BS EN1092 PN16
- Conforms to BS EN12334
- Sizes DN50-400 conform to BS 5153 (BS EN558-1 Series 10)

Pressure/Temperature

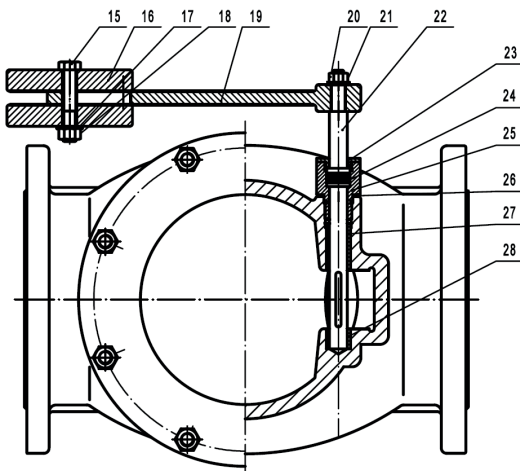
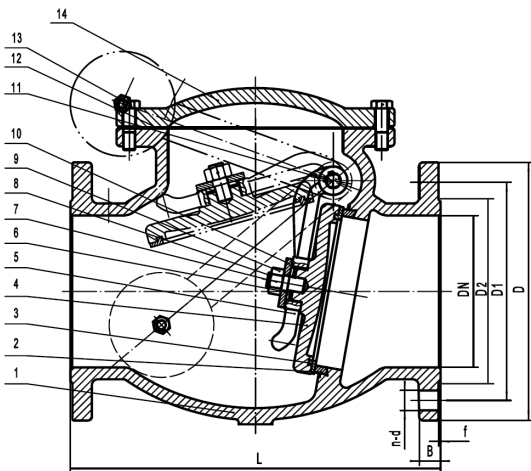
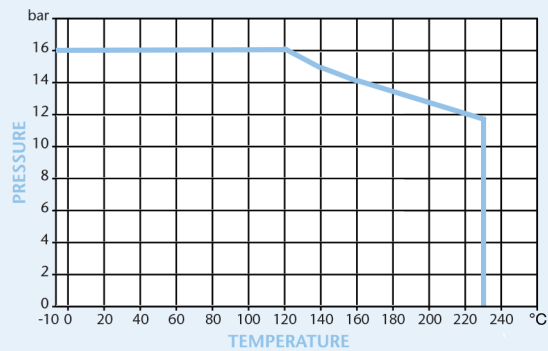

	50	65	80	100	125	150	200	250	300	350	400	450	500	600
L	203	216	241	292	330	356	495	622	699	787	914	914	1016	1219
D	165	185	200	220	250	285	340	405	460	520	580	640	715	840
D1	125	145	160	180	210	240	295	355	410	470	525	585	650	770
D2	99	118	132	156	184	211	266	319	3780	429	480	548	609	720
B	20	20	22	24	26	26	30	32	32	36	38	40	42	48
n-d	4-19	4-19	8-19	8-19	8-19	8-23	12-23	12-28	12-28	16-28	16-31	20-31	20-34	20-37
f	3	3	3	3	3	3	3	3	4	4	4	4	4	5
Kgs	13.8	19.5	23.6	38	59	79.6	126.9	243	291	456	586	710	900	1350

N.	Part Name	Materials
1	Body	Cast Iron - BS EN1561 EN-GJL-250
2	Seat Ring	Cast Bronze - BS1400 LG2
3	Disc Ring	Cast Bronze - BS1400 LG2
4	Disc	Cast Iron - BS EN1561 EN-GJL-250
5	Hanger	Ductile Iron - BS EN1563 EN-GJS-450-10
6	Pin	Stainless Steel - BS970 304S15
7	Split Pin	Stainless Steel - BS970 304S15
8	Disc Screw	Steel - BS970 43A
9	Nut	Steel - BS970 43A
10	Washer	Steel - BS970 43A
11	Bond	Steel - BS970 43A
12	Gasket	Graphite
13	Bolt	Steel - BS970 43A
14	Bonnet	Cast Iron - BS EN1561 EN-GJL-250
15	Bolt	Steel - BS970 43A
16	Balance Weight	Cast Iron - BS EN1561 EN-GJL-250
17	Washer	Steel - BS970 43A
18	Nut	Steel - BS970 43A
19	Connecting Lever	Ductile Iron - BS EN1563 EN-GJS-450-10
20	Nut	Steel - BS970 43A
21	Washer	Steel - BS970 43A
22	Hanger Axle	Stainless Steel - BS970 304S15
23	Gland Nut	Brass - BS2874 CZ122
24	O-Ring	EPDM - BSEN681-1 IRHD66-75
25	Stuffing Box	Brass - BS2874 CZ122
26	Washer	Teflon
27	Outside Bush	Brass - BS2874 CZ122
28	Inside Bush	Brass - BS2874 CZ122

Technical Data

Max Pressure	16 Bar
Working Temperature	-10°C to +230°C

Dimensions in mm

This data sheet is designed as a guide and should not be regarded as wholly accurate in every detail. We reserve the right to amend the specification of any product without notice.