

## PN25 Ductile Iron Double Regulating Valve (DRV)

### Features

- Flange Mounting PN25 Only
- Flange conforms to BS EN1092 PN25
- Position indicator
- Double regulating device
- Supplied with 2 test points and extensions
- EPDM cone seating gives tight shut off
- Body ductile iron
- Conforms to BS 5152 / BS 7350



### Pressure/Temperature

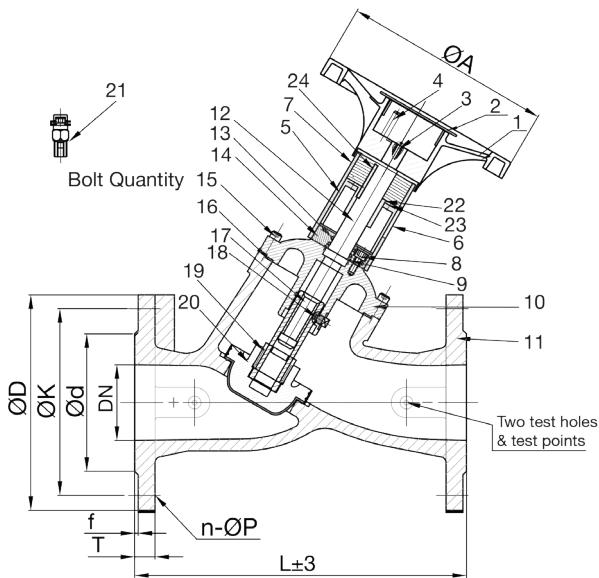
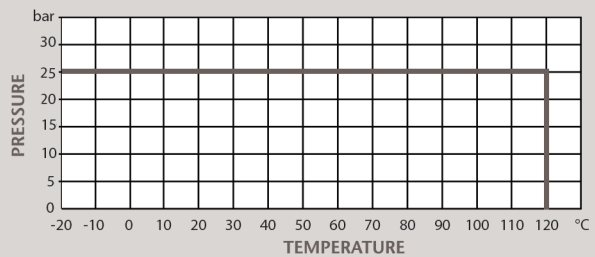

DN	50	65	80	100	125	150	200
L	230	290	310	350	400	480	600
ØD	165	185	200	235	270	300	360
ØK	125	145	160	190	220	250	310
Ød	99	118	132	156	184	211	274
n-ØP	4-Ø19	8-Ø19	8-Ø19	8-Ø23	8-Ø28	8-Ø28	12-Ø28
T	19	19	19	19	19	20	22
f	3	3	3	3	3	3	3
A	180	180	180	250	250	250	350
Bolt Qty	6	6	6	6	8	8	12
Kvs	48.2	82.6	117.4	211.4	381.5	462.4	790
Kgs	14.4	18.4	24.2	34.5	48.3	64.4	123

N.	Part Name	Materials
1	Handwheel	Aluminium Alloy / Steel
2	Handwheel Cover	Plastic
3	Handwheel Lock Screw	Stainless Steel 304
4	Adjusting Screw	Stainless Steel 304
5	Indication Tube	Plastic
6	Indicator Mask	Plastic
7	Connect Bushing	Plastic
8, 15	Screw	Steel
9, 13	O-Ring	EPDM
10	Cover	Cast Iron
11	Body	Ductile Iron
12	Stem	Stainless Steel 410
14	Packing Gland	Stainless Steel 410
16	Gasket	Graphite
17	Stem Nut	HPb59-1
18	Positional Screw	Stainless Steel 304
19	Nut Cover	HPb59-1
20	Disc	Cast Iron + EPDM
21	Test Points	
22	Drive Plate	Stainless Steel 410
23	Screw	Carbon Steel
24	Flat Key	Stainless Steel 410

### Technical Data

Max Pressure	25 Bar
Working Temperature	-20°C to +120°C

Dimensions in mm

This data sheet is designed as a guide and should not be regarded as wholly accurate in every detail. We reserve the right to amend the specification of any product without notice.