

ART 1100 with Copper Ball

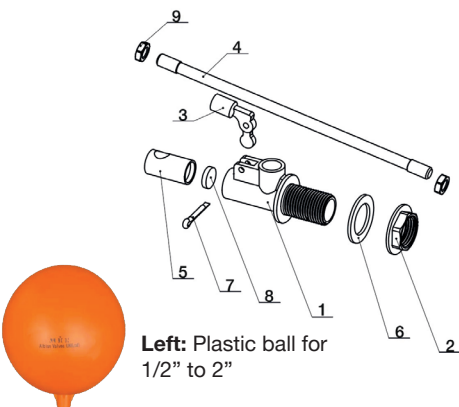

ART 1100 with Plastic Ball

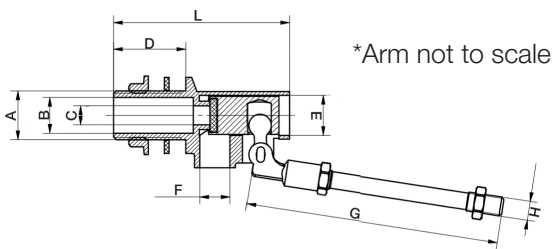

Plastic floats - Polyethylene

Diameter Size	4 1/2"	5"	8"	10"
Kgs	0.07	0.09	0.35	0.65



Left: Copper ball for 1/2" to 1"
Right: Copper ball for 1.1/4" to 2"



Copper floats

Diameter Size	4 1/2"	5"	8"	10"
Kgs	0.08	0.13	0.4	0.65

Technical Data

Max Pressure	16 Bar
Working Temperature	-20°C to +90°C

Float Valve

Features

- Screwed BSP Parallel (ISO 228/1)
- Supplied with locknut
- Machined fixed flange on valve body
- No jam single lever action
- Replaceable seals
- Copper and plastic float option available
- DZR Brass option also available

Pressure / Temperature

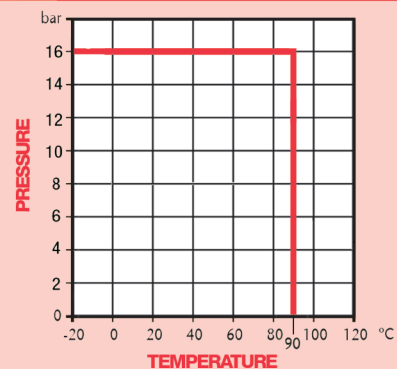

A	1/2"	3/4"	1"	1 1/4"	1 1/2"	2"
B	15	21	26.5	34.5	40	49.5
C	8	10	10	15	17	17
D	30	30	36	50	50	50
E	16.7	20.7	20.5	21.5	21.5	21.5
F	12.5	15	15	24	27	27
G	220	240	270	330	380	430
H	M8	M8	M8	M10	M10	M12
L	73	75	84	126	131	131
Float Size	4 1/2"	4 1/2"	5"	8"	8"	10"
Kgs (excl ball)	0.24	0.31	0.41	0.81	1.05	1.45

Size	Pressure	Flow	Pressure	Flow
1/2"	50psi	20 gpm	100psi	31 gpm
3/4"	50psi	40 gpm	100psi	60 gpm
1"	50psi	100 gpm	100psi	150 gpm
1.1/4" - 2"	50psi	250 gpm	100psi	348 gpm

N.	Part Name	Materials
1	Body	Brass HPb57-3
2	Back Nut	Brass HPb57-3
3	Plunger	Brass HPb57-3
4	Arm	Brass HPb57-3
5	Piston	Brass HPb57-3
6	Washer	EPDM
7	Pin	Brass HPb57-3
8	Washer	EPDM
9	Locking Nut	Stainless Steel 304

Dimensions in mm

This data sheet is designed as a guide and should not be regarded as wholly accurate in every detail. We reserve the right to amend the specification of any product without notice.