

Brass Valves

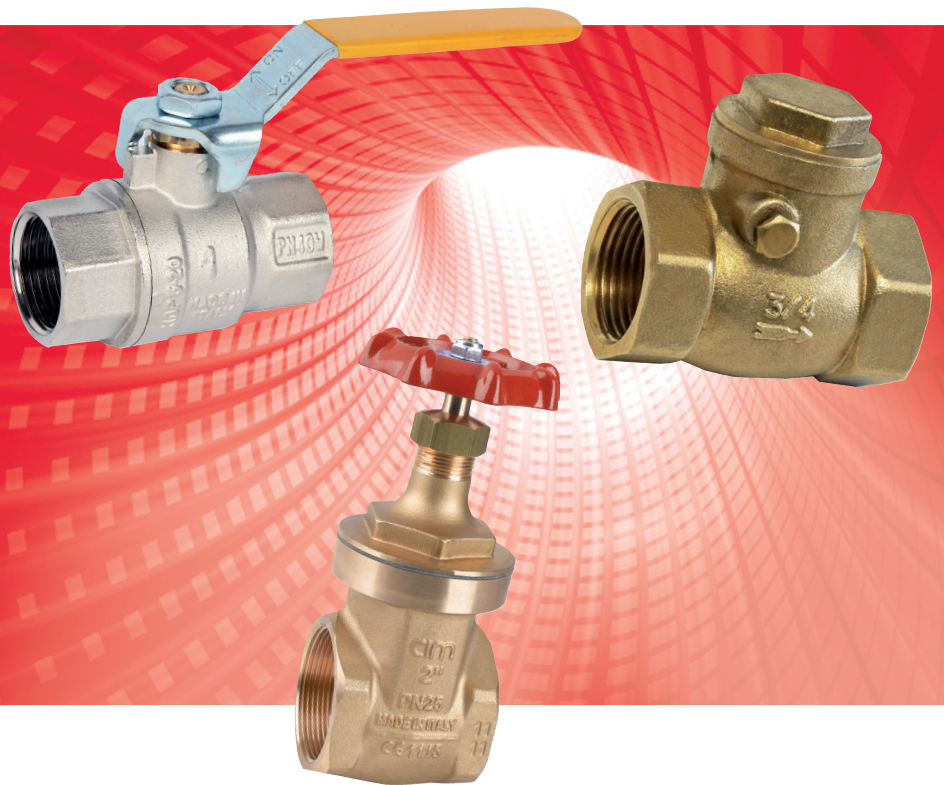

Product Information

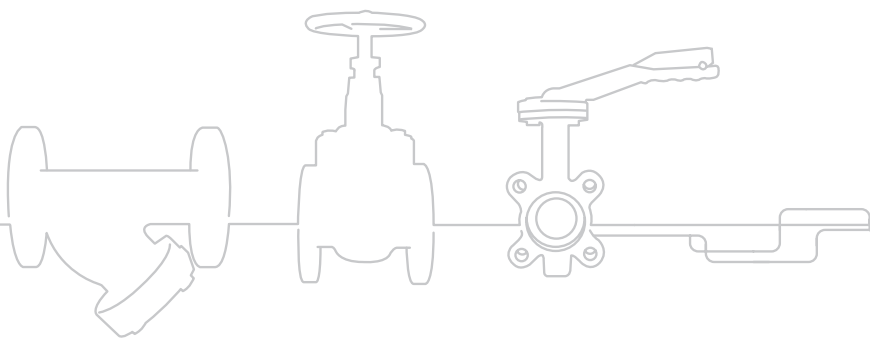

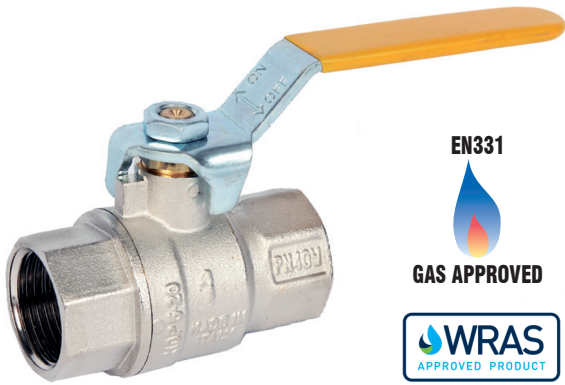

PN40 Brass Ball Valve

Features

- Screwed BSP Parallel (ISO 228/1)
- PTFE Seats & Seals
- Anti-Blow Out Stem
- Full Bore
- Locking Lever & Tee Handle Options Available
- WRAS & EN331 Approved

Pressure / Temperature

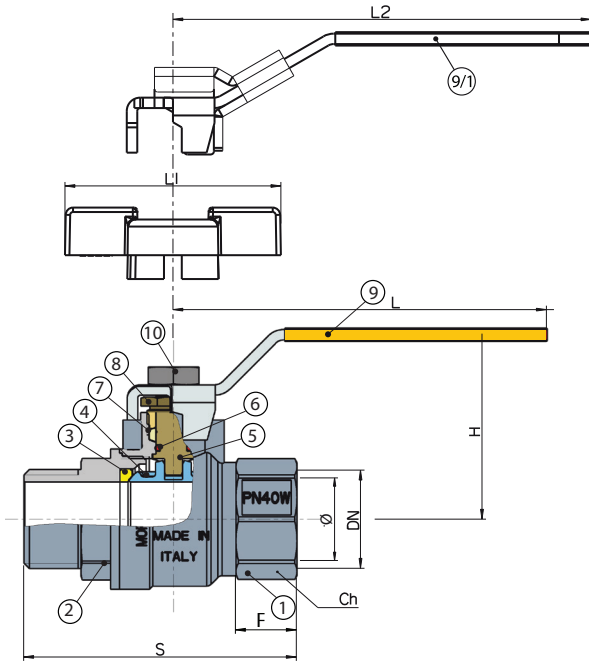
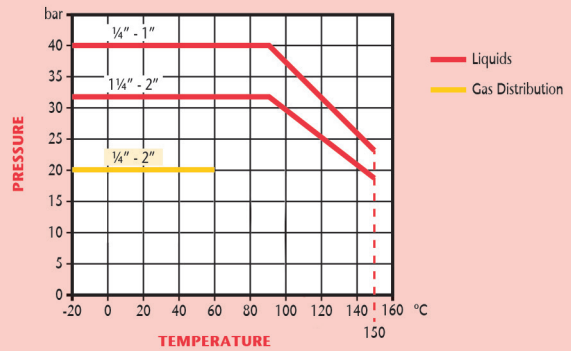

DN	1/4"	3/8"	1/2"	3/4"	1"	1 1/4"	1 1/2"	2"
Ø	10	10	15	20	25	32	40	50
F	10	10	15	16	19	21	21	26
S	45	45	63	71	83	92	104	124
H	41	41	54	58	66	71	80	88
L	80	80	90	90	125	125	140	140
L1	52	52	62	62	72			
L2	95	95	120	120	150	150	160	160
Ch	21	21	26	31	38	48	55	68
Kgs	0.14	0.14	0.26	0.37	0.57	0.84	1.46	2.09

Technical Data - Gas Distribution

Max Pressure	20 Bar
Working Temperature	-20°C to +60°C

Technical Data

Max Pressure	1/4"-1"	40 Bar
	1 1/4"-2"	32 Bar
Working Temperature	1/4"-2"	-20°C to +150°C

N.	Part Name	Materials
1	Body	Brass/Nickel Plated
2	Body End	Brass/Nickel Plated
3	Seat	PTFE
4	Ball	Brass/Chrome Plated
5	Stem	Brass
6	'O' Rings	HNBR
7	Stem Seat	PTFE
8	Packing Nut	Brass
9	Lever	Steel/PVC-Plastic Coated
9/1	Lockable Lever	Steel/PVC-Plastic Coated
10	Nut	Steel/Zinc Plated

Dimensions in mm

This data sheet is designed as a guide and should not be regarded as wholly accurate in every detail. We reserve the right to amend the specification of any product without notice.

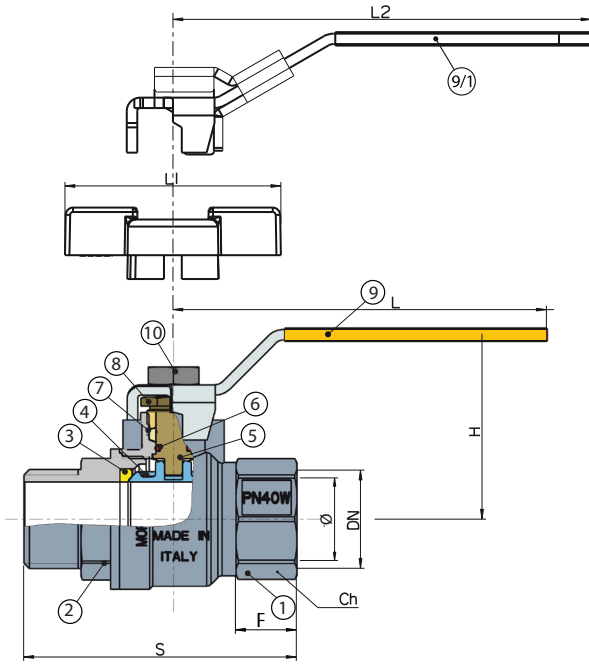
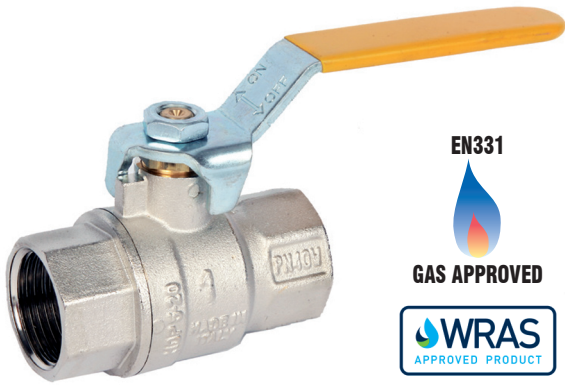

Technical Data - Gas Distribution		
Max Pressure	1/4" - 2"	20 Bar
	2 1/2" - 4"	10 Bar
Working Temperature	-20°C to +60°C	

Technical Data		
Max Pressure	1/4" - 1"	40 Bar
	1 1/4" - 2"	32 Bar
	2 1/2" - 4"	25 Bar
Working Temperature	-20°C to +150°C	

Dimensions in mm
 This data sheet is designed as a guide and should not be regarded as wholly accurate in every detail. We reserve the right to amend the specification of any product without notice.

PN40 Brass Ball Valve

Features

- Screwed BSP Taper (ISO 7/1)
- PTFE Seats & Seals
- Anti-Blow Out Stem
- Full Bore
- Locking Lever & Tee Handle Options Available
- WRAS & EN331 Approved

Pressure / Temperature

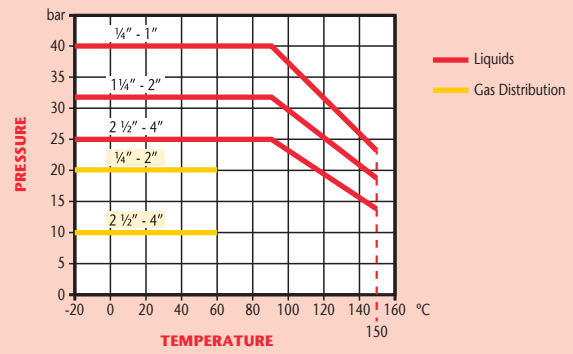

DN	1/4"	3/8"	1/2"	3/4"	1"	1 1/4"	1 1/2"	2"	2 1/2"	3"	4"
Ø	10	10	15	20	25	32	40	50	61	74	95
F	10	10	15	16	19	21	21	26	27	28	35
S	45	45	63	71	83	92	104	124	140	159	195
H	41	41	54	58	66	71	80	88	131	140	156
L	80	80	90	90	125	125	140	140	250	250	250
L1	52	52	62	62	72						
L2	95	95	120	120	150	150	160	160			
Ch	21	21	26	31	38	48	55	68	85	99	125
Kgs	0.14	0.14	0.26	0.37	0.57	0.84	1.46	2.09	4.30	6.00	9.25

N.	Part Name	Materials
1	Body	Brass/Nickel Plated
2	Body End	Brass/Nickel Plated
3	Seat	PTFE
4	Ball	Brass/Chrome Plated
5	Stem	Brass
6	'O' Rings	HNBR
7	Stem Seat	PTFE
8	Packing Nut	Brass
9	Lever	Steel/PVC-Plastic Coated
9/1	Lockable Lever	Steel/PVC-Plastic Coated
10	Nut	Steel/Zinc Plated

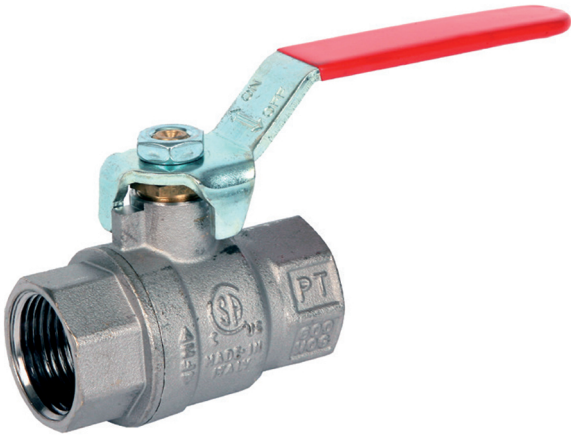

PN40 Brass Ball Valve

Features

- Screwed NPT (ANSI B1.20.1)
- PTFE Seats & Seals
- Anti-Blow Out Stem
- Full Bore
- Locking Lever & Tee Handle Options Available
- Complies to SA, UL & FM

Pressure / Temperature

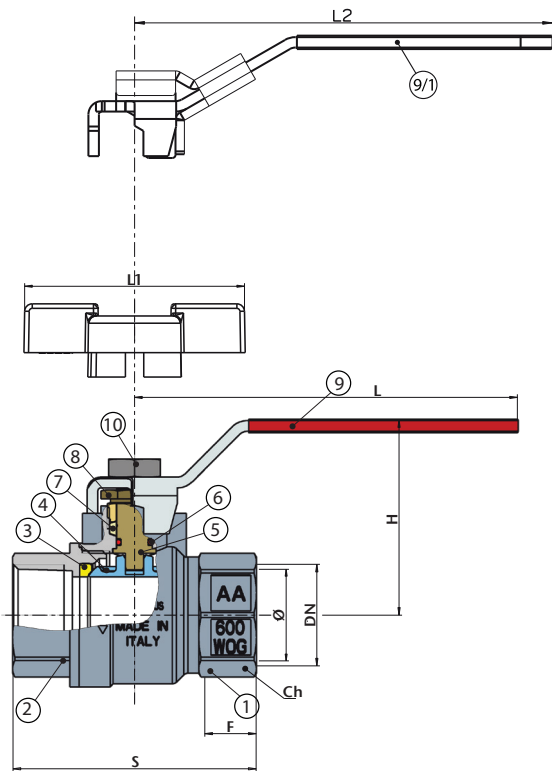
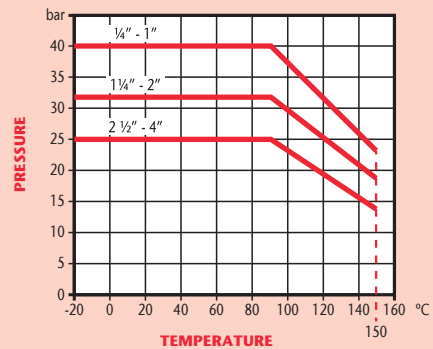

DN	1/4"	3/8"	1/2"	3/4"	1"	1 1/4"	1 1/2"	2"	2 1/2"	3"	4"
Ø	10	10	15	20	25	32	40	50	61	74	95
F	12	12	16	17	19,5	21	21	22	27,5	30,5	38
S	45	45	60	67	80	89	98	112	140	159	196
H	41	41	54	58	66	71	80	88	131	140	156
L	80	80	90	90	125	125	140	140	250	250	250
L1	52	52	62	62	72						
L2	95	95	120	120	150	150	160	160			
Ch	21	21	26	31	38	48	55	68	85	99	125
Kgs	0.14	0.14	0.26	0.37	0.57	0.84	1.46	2.09	4.30	6.00	9.25

Technical Data

Max Pressure	1/4"-1"	40 Bar
	1 1/4"-2"	32 Bar
	2 1/2"-4"	25 Bar
Working Temperature	-20°C to +150°C	

N.	Part Name	Materials
1	Body	Brass/Nickel Plated
2	Body End	Brass/Nickel Plated
3	Seat	PTFE
4	Ball	Brass/Chrome Plated
5	Stem	Brass
6	'O' Rings	HNBR
7	Stem Seat	PTFE
8	Packing Nut	Brass
9	Lever	Steel/PVC-Plastic Coated
9/1	Lockable Lever	Steel/PVC-Plastic Coated
10	Nut	Steel/Zinc Plated

Dimensions in mm

This data sheet is designed as a guide and should not be regarded as wholly accurate in every detail. We reserve the right to amend the specification of any product without notice.

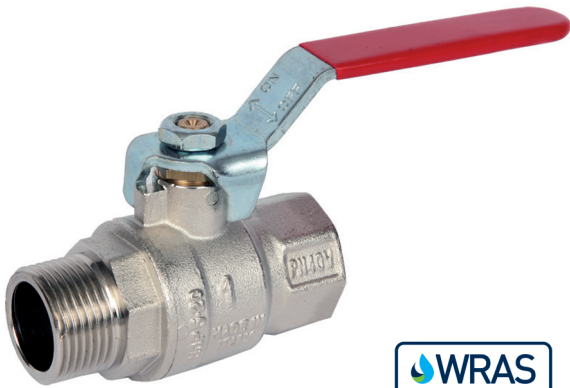

PN40 Brass Ball Valve

Features

- Screwed BSP Parallel M/F Ends (ISO 228/1)
- PTFE Seats & Seals
- Anti-Blow Out Stem
- Full Bore
- Locking Lever & Tee Handle Options Available
- WRAS Approved

Pressure / Temperature

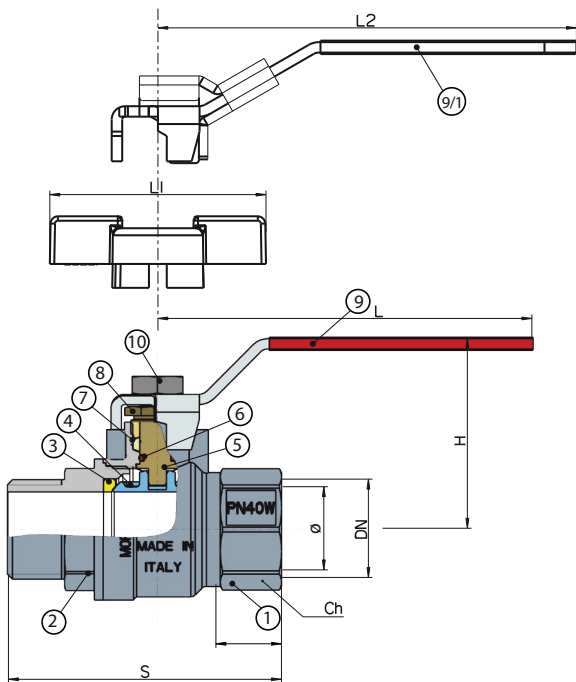
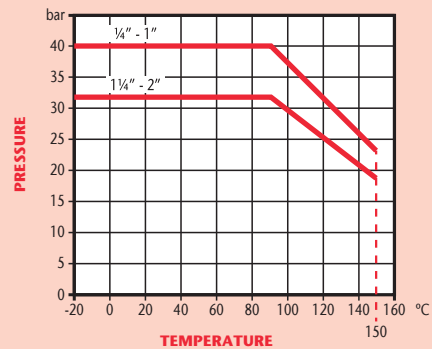

DN	1/4"	3/8"	1/2"	3/4"	1"	1 1/4"	1 1/2"	2"
Ø	10	10	15	20	25	32	40	50
F	10	12	15	16	19	20.5	21.5	24.5
S	42	54	70	80	92	102	117	137
H	41	41	54	58	66	71	80	88
L	80	80	90	90	125	125	140	140
L1	52	52	62	62	72			
L2	95	95	120	120	150	150	160	160
Ch	21	21	26	31	38	48	55	68
Kgs	0.11	0.13	0.27	0.37	0.62	0.93	1.35	2.14

Technical Data

Max Pressure	1/4"-1"	40 Bar
	1/4"-2"	32 Bar
Working Temperature		-20°C to +150°C

N.	Part Name	Materials
1	Body	Brass/Nickel Plated
2	Body End	Brass/Nickel Plated
3	Seat	PTFE
4	Ball	Brass/Chrome Plated
5	Stem	Brass
6	'O' Rings	HNBR
7	Stem Seat	PTFE
8	Packing Nut	Brass
9	Lever	Steel/PVC-Plastic Coated
9/1	Lockable Lever	Steel/PVC-Plastic Coated
10	Nut	Steel/Zinc Plated

Dimensions in mm

This data sheet is designed as a guide and should not be regarded as wholly accurate in every detail. We reserve the right to amend the specification of any product without notice.

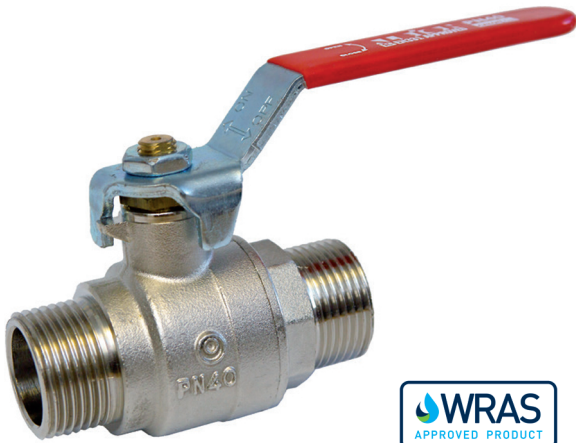

PN40 Brass Ball Valve

Features

- Screwed BSP Parallel M/M Ends (ISO 228/1)
- PTFE Seats & Seals
- Anti-Blow Out Stem
- Full Bore
- Locking Lever & Tee Handle Options Available
- WRAS Approved

Pressure / Temperature

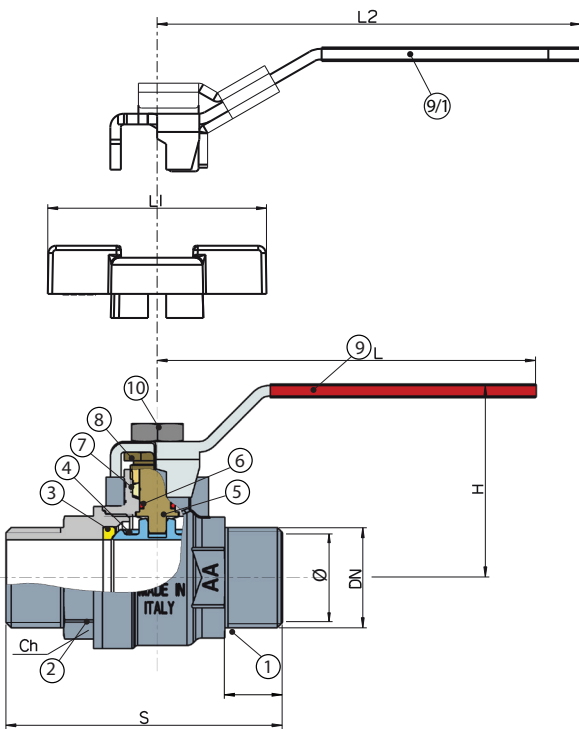
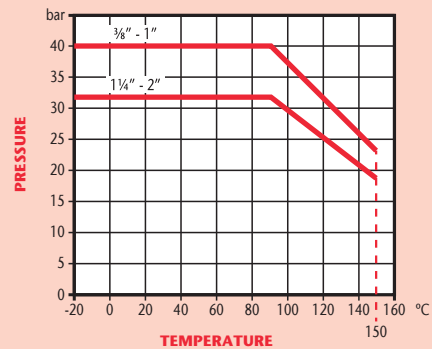

Technical Data

Max Pressure	3/8" - 1"	40 Bar
	1 1/4" - 2"	32 Bar
Working Temperature	-20°C to +150°C	

DN	3/8"	1/2"	3/4"	1"	1 1/4"	1 1/2"	2"
Ø	10	15	20	25	32	40	50
F	12	15	16	19	20.5	21.5	24.5
S	54	68	77	92	106	111	138
H	41	54	58	66	71	80	88
L	80	90	90	125	125	140	140
L1	52	62	62	72			
L2	95	120	120	150	150	160	160
Ch	21	26	31	38	48	55	68
Kgs	0.13	0.27	0.37	0.62	0.93	1.35	2.14

N.	Part Name	Materials
1	Body	Brass/Nickel Plated
2	Body End	Brass/Nickel Plated
3	Seat	PTFE
4	Ball	Brass/Chrome Plated
5	Stem	Brass
6	'O' Rings	FP
7	Stem Seat	PTFE
8	Packing Nut	Brass
9	Lever	Steel/PVC-Plastic Coated
9/1	Lockable Lever	Steel/PVC-Plastic Coated
10	Nut	Steel/Zinc Plated

Dimensions in mm

This data sheet is designed as a guide and should not be regarded as wholly accurate in every detail. We reserve the right to amend the specification of any product without notice.



PN40 Brass Ball Valve

Features

- Screwed BSP Parallel (ISO 228/1)
- Anti-Blow-Out Stem
- PTFE Seats & Seals
- Full Bore
- WRAS & EN331 Approved
- Locking Lever (1/2" to 2" only) & Tee Handle (1/4" to 1" only) options available

Pressure / Temperature

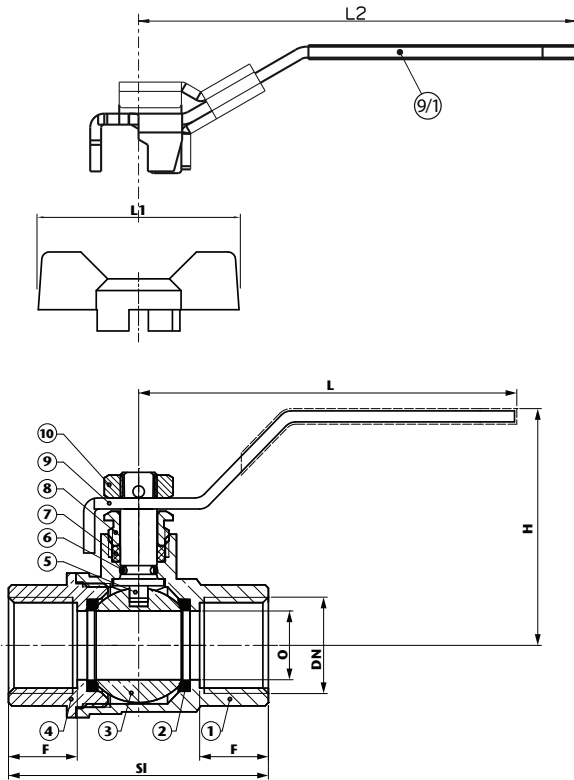
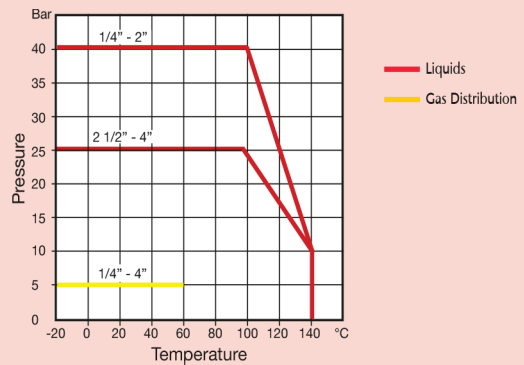

Technical Data - Gas Distribution

Max Pressure	1/4" - 4"	5 Bar
Working Temperature		-20°C to +60°C

Technical Data

Max Pressure	1/4" - 2"	40 Bar
	2 1/2" - 4"	25 Bar
Working Temperature		-20°C to +140°C

DN	1/4"	3/8"	1/2"	3/4"	1"	1 1/4"	1 1/2"	2"	2 1/2"	3"	4"
O	10	10	14.5	19	24.5	31.5	40	49	62	73	90
F	11.5	11.5	15	18	19.5	20	21	26.5	31	36.8	41.6
S1	45	45	57	67	77	88	99	121	146	168	199
H	41	41	52	49	62	81	90	96	122	132	143
L	82	82	87.5	100	125	141	141	165	225	225	280
L1	52	52	52	52	62						
L2			100	100	125	150	150	165			
Kgs	0.14	0.14	0.20	0.26	0.41	0.61	0.95	1.35	3.02	3.99	6.51

N.	Part Name	Materials
1	Body	Brass/Nickel Plated
2	Seat	PTFE
3	Ball	Brass/Chrome Plated
4	Body End	Brass/Nickel Plated
5	Stem	Brass
6	'O' Ring	NBR
7	Stem Packing	PTFE
8	Lock Nut	Brass
9	Lever	Steel
9/1	Lockable Lever	Steel/PVC Plastic Coated
10	Nut	Steel

Dimensions in mm

This data sheet is designed as a guide and should not be regarded as wholly accurate in every detail. We reserve the right to amend the specification of any product without notice.

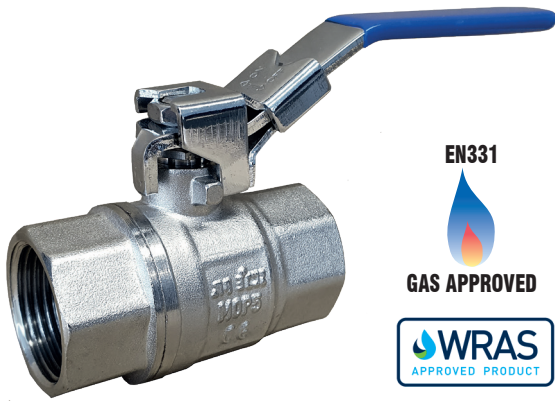

PN40 Brass Ball Valve Complete with Locking Lever

Features

- Screwed BSP Parallel (ISO 228/1)
- Anti-Blow-Out Stem
- PTFE Seats & Seals
- Full Bore
- WRAS & EN331 Approved

Pressure / Temperature

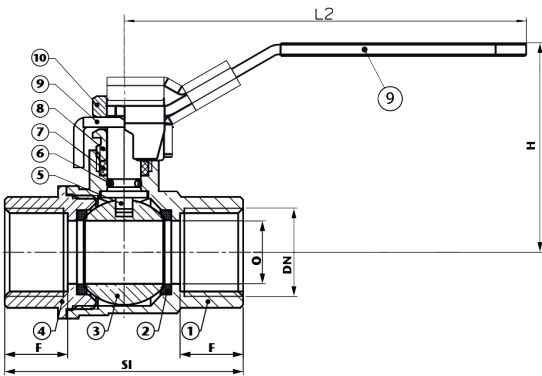
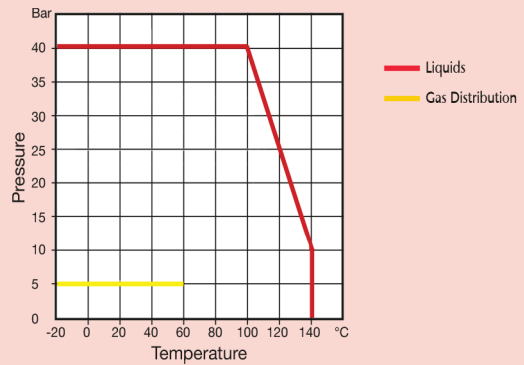

Technical Data - Gas Distribution

Max Pressure	5 Bar
Working Temperature	-20°C to +60°C

Technical Data

Max Pressure	40 Bar
Working Temperature	-20°C to +140°C

DN	1/2"	3/4"	1"	1 1/4"	1 1/2"	2"
O	14.5	19	24.5	31.5	40	49
F	15	18	19.5	20	21	26.5
S1	57	67	77	88	99	121
H	52	49	62	81	90	96
L2	100	100	125	150	150	165
Kgs	0.29	0.35	0.50	0.70	1.04	1.44

N.	Part Name	Materials
1	Body	Brass/Nickel Plated
2	Seat	PTFE
3	Ball	Brass/Chrome Plated
4	Body End	Brass/Nickel Plated
5	Stem	Brass
6	'O' Ring	NBR
7	Stem Packing	PTFE
8	Lock Nut	Brass
9	Lockable Lever	Steel/PVC Plastic Coated
10	Nut	Steel



PN40 Brass Ball Valve

Features

- Screwed BSP Taper (ISO 7/1)
- Anti-Blow-Out Stem
- PTFE Seats & Seals
- Full Bore
- WRAS & EN331 Approved
- Locking Lever (1/2" to 2" only) & Tee Handle (1/4" to 1" only) options available

Pressure / Temperature

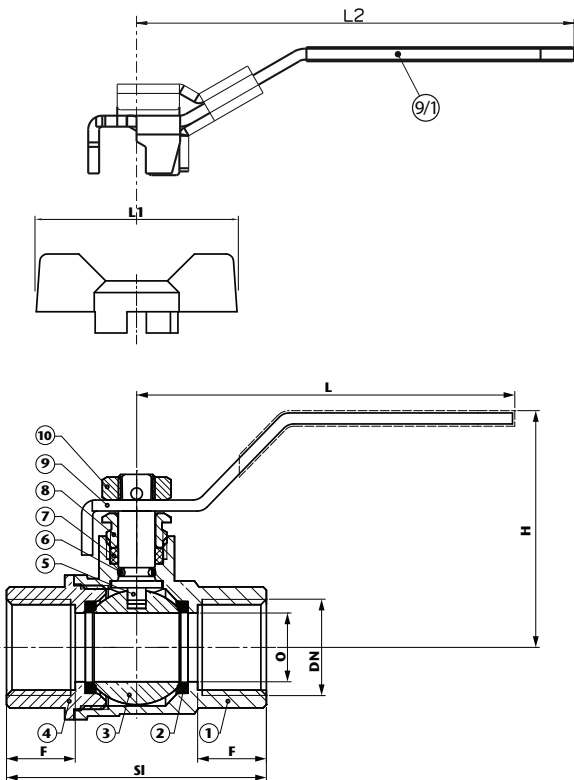
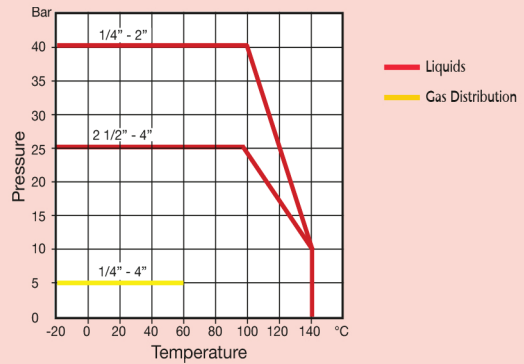

Technical Data - Gas Distribution

Max Pressure	1/4"-4"	5 Bar
Working Temperature		-20°C to +60°C

Technical Data

Max Pressure	1/4" - 2"	40 Bar
	2 1/2" - 4"	25 Bar
Working Temperature		-20°C to +140°C

DN	1/4"	3/8"	1/2"	3/4"	1"	1 1/4"	1 1/2"	2"	2 1/2"	3"	4"
O	10	10	14.5	19	24.5	31.5	40	49	62	73	90
F	11.5	11.5	15	18	19.5	20	21	26.5	31	36.8	41.6
S1	45	45	57	67	77	88	99	121	146	168	199
H	41	41	52	49	62	81	90	96	122	132	143
L	82	82	87.5	100	125	141	141	165	225	225	280
L1	52	52	52	52	62						
L2			100	100	125	150	150	165			
Kgs	0.14	0.14	0.20	0.26	0.41	0.61	0.95	1.35	3.07	4.12	6.68

N.	Part Name	Materials
1	Body	Brass/Nickel Plated
2	Seat	PTFE
3	Ball	Brass/Chrome Plated
4	Body End	Brass/Nickel Plated
5	Stem	Brass
6	'O' Ring	NBR
7	Stem Packing	PTFE
8	Lock Nut	Brass
9	Lever	Steel
9/1	Lockable Lever	Steel/PVC Plastic Coated
10	Nut	Steel

Dimensions in mm

This data sheet is designed as a guide and should not be regarded as wholly accurate in every detail. We reserve the right to amend the specification of any product without notice.



PN40 Brass Ball Valve

Features

- Screwed NPT (ANSI B1.20.1)
- Anti-Blow-Out Stem
- PTFE Seats & Seals
- Full Bore
- Locking Lever (1/2" to 2" only) & Tee Handle (1/4" to 1" only) options available

Pressure / Temperature

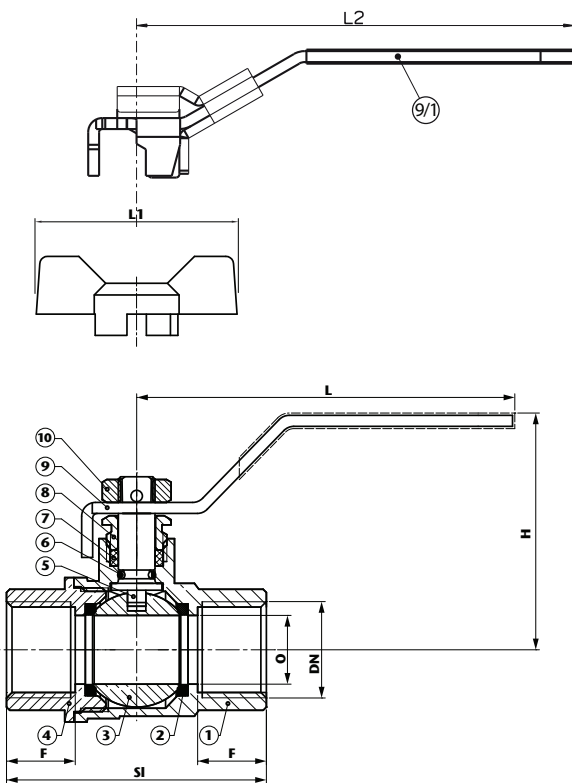
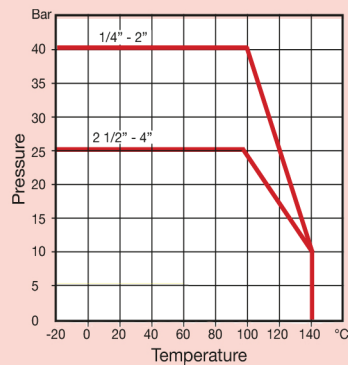

DN	1/4"	3/8"	1/2"	3/4"	1"	1 1/4"	1 1/2"	2"	2 1/2"	3"	4"
O	10	10	14.5	19	24.5	31.5	40	49	62	73	90
F	11.5	11.5	15	18	19.5	20	21	26.5	31	36.8	41.6
SI	45	45	57	67	77	88	99	121	146	168	199
H	41	41	52	49	62	81	90	96	122	132	143
L	82	82	87.5	100	125	141	141	165	225	225	280
L1	52	52	52	52	62						
L2			100	100	125	150	150	165			
Kgs	0.14	0.14	0.20	0.26	0.41	0.61	0.95	1.35	3.30	4.20	6.75

Technical Data

Max Pressure	1/4" - 2"	40 Bar
	2 1/2" - 4"	25 Bar
Working Temperature	1/4" - 4"	-20°C to +140°C

N.	Part Name	Materials
1	Body	Brass/Nickel Plated
2	Seat	PTFE
3	Ball	Brass/Chrome Plated
4	Body End	Brass/Nickel Plated
5	Stem	Brass
6	'O' Ring	NBR
7	Stem Packing	PTFE
8	Lock Nut	Brass
9	Lever	Steel
9/1	Lockable Lever	Steel/PVC Plastic Coated
10	Nut	Steel

Dimensions in mm

This data sheet is designed as a guide and should not be regarded as wholly accurate in every detail. We reserve the right to amend the specification of any product without notice.

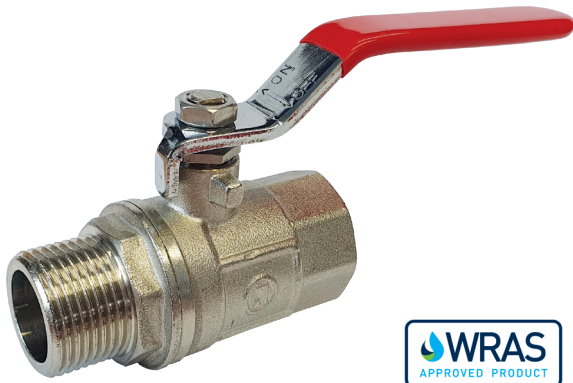

PN40 Brass Ball Valve

Features

- Screwed BSP Parallel M/F Ends (ISO 228/1)
- PTFE Seats & Seals
- Anti-Blow Out Stem
- Full Bore
- Locking Lever, Thermal Extension & Tee Handle Options Available
- WRAS Approved

Pressure / Temperature

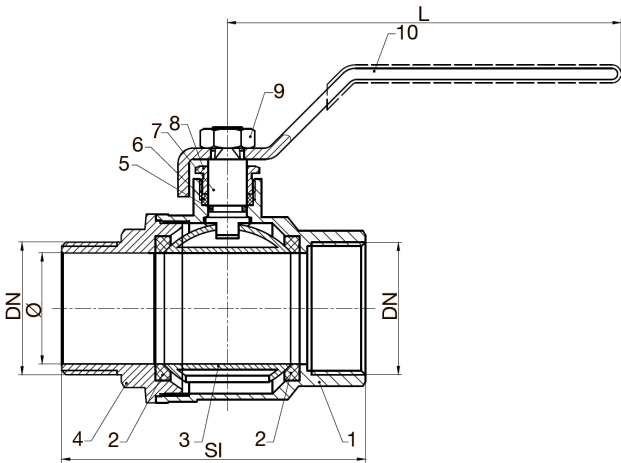
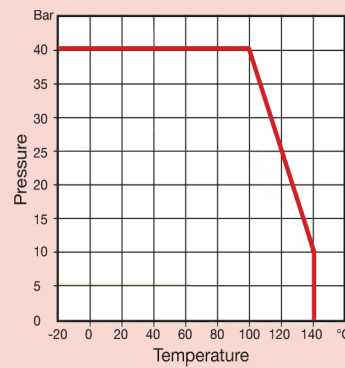

DN	1/4"	3/8"	1/2"	3/4"	1"	1 1/4"	1 1/2"	2"
Ø	8.5	10	14.5	19	24.5	31.5	40	49
SI	52	52	65	72.5	82	96.5	109.6	130
L	82	82	88	100	125	140	140	165
Kgs	0.15	0.14	0.23	0.32	0.48	0.78	1.05	1.62

Technical Data

Max Pressure	40 Bar
Working Temperature	-20°C to +140°C

N.	Part Name	Materials
1	Body	Brass - CW617N
2	Ball Seat	PTFE
3	Ball	Brass CW617N
4	Bonnet	Brass - CW617N
5	O-Ring	NBR
6	Packing	PTFE
7	Stem	Brass - Hpb59-T
8	Lock Nut	Brass - Hpb59-T
9	Nut	Steel - #201
10	Handle	Steel Q235 + PVC

Dimensions in mm

This data sheet is designed as a guide and should not be regarded as wholly accurate in every detail. We reserve the right to amend the specification of any product without notice.

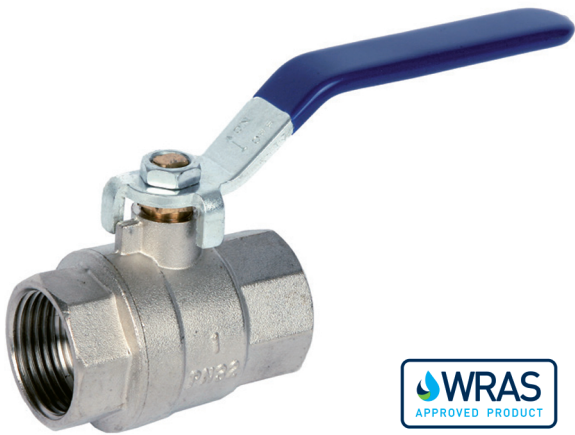

PN32 Brass Ball Valve

Features

- Screwed BSP Parallel (ISO 228/1)
- Anti-Blow-Out Stem
- PTFE Seat
- Full Bore
- WRAS Approved

Pressure / Temperature

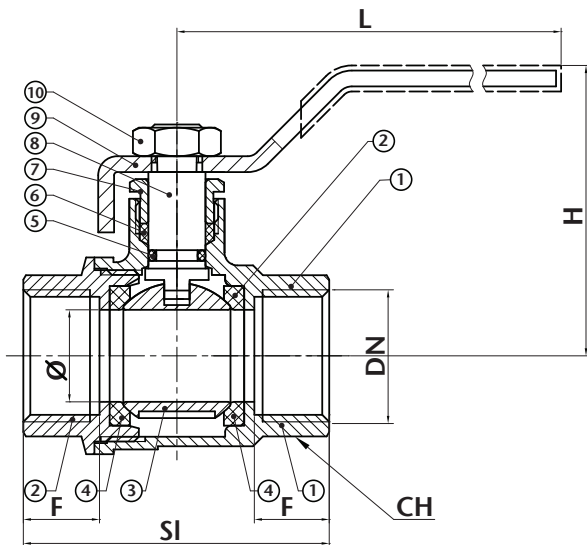
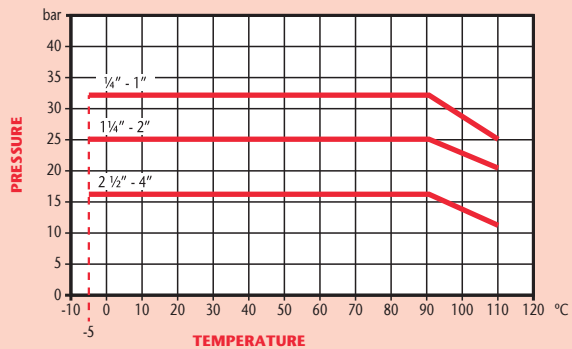

DN	1/4"	3/8"	1/2"	3/4"	1"	1 1/4"	1 1/2"	2"	2 1/2"	3"	4"
Ø	10.5	10.5	15	20	25	32	40	50	62	75	95
F	9.5	10	10	11	13	15.5	16.5	18	23.5	25	27
SI	42	43.5	49	57.5	69.5	80.5	91.5	110	132	150	181
H	39.5	39.5	42.5	46	69	69	83.5	83.5	107	116.5	152
L	80	80	92	92	105	105	150	150	225	225	250
CH	17.5	20.5	25	31	38	47	54	66	84	96	123
Kgs	0.12	0.12	0.18	0.27	0.42	0.71	0.93	1.52	2.90	3.82	7.03

Technical Data

Max Pressure	1/4"-1"	32 Bar
	1 1/4"-2"	25 Bar
	2 1/2"-4"	16 Bar
Working Temperature	-5°C to +110°C	

N.	Part Name	Materials
1	Body	Brass/Nickel Plated
2	Body End	Brass/Nickel Plated
3	Ball	Brass/Chrome Plated
4	Seat	PTFE
5	'O' Ring	NBR
6	Stem Packing	PTFE
7	Lock Nut	Brass
8	Stem	Brass
9	Lever	Steel/Zinc Plated
10	Nut	Steel/Zinc Plated

Dimensions in mm

This data sheet is designed as a guide and should not be regarded as wholly accurate in every detail. We reserve the right to amend the specification of any product without notice.



PN25 Brass Ball Valve

Features

- Compression Ends
- Anti-Blow-Out Stem
- PTFE Seats & Seals
- Full Bore
- WRAS & EN331 Approved
- Locking Lever & Tee Handle Options Available

Pressure / Temperature

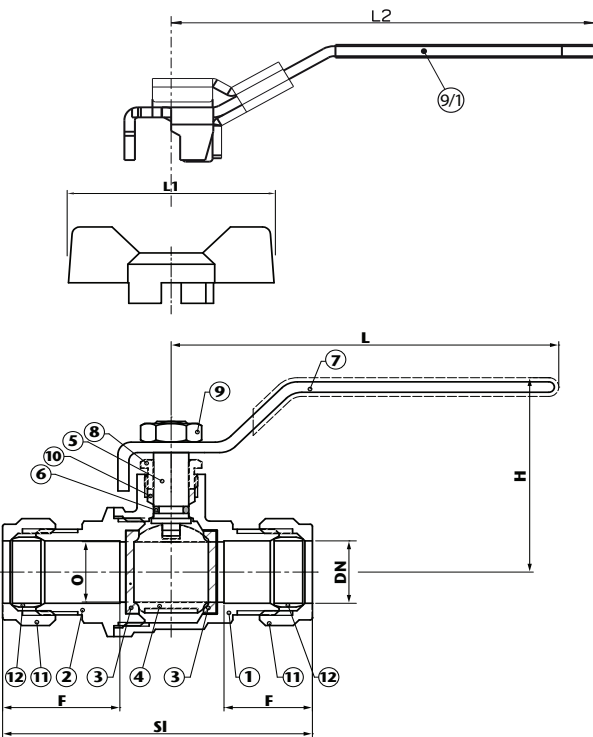
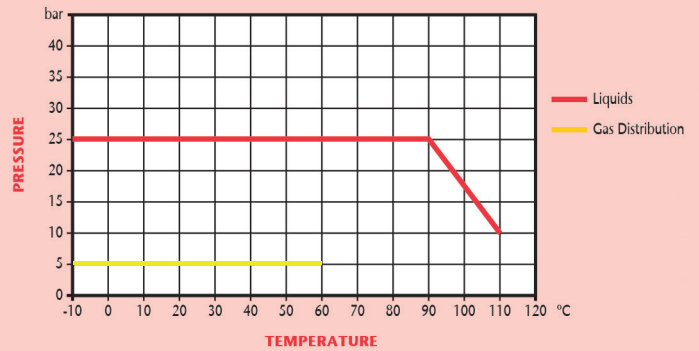

DN	15	22	28	35	42	54
O	14.5	19.0	24.5	31.5	39.5	49.5
F	18.75	20.25	22	24	28	32
SI	70.5	80	91.5	109	123	150
H	52.5	54.5	69	78	86	100
L	83	93	124	133	133	158
L1	52	52	62			
L2	100	100	125	150	150	165
Kgs	0.23	0.34	0.57	0.94	1.81	2.15

Technical Data - Gas Distribution

Max Pressure	5 Bar
Working Temperature	-10°C to +60°C

Technical Data

Max Pressure	25 Bar
Working Temperature	-10°C to +110°C

N.	Part Name	Materials
1	Body	Brass/Nickel Plated
2	Body End	Brass/Nickel Plated
3	Seat	PTFE
4	Ball	Brass/Chrome Plated
5	Stem	Brass
6	O-ring	NBR
7	Lever	Steel
8	Lock Nut	Brass
9	Nut	Steel
9/1	Lockable Lever	Steel/PVC Plastic Coated
10	Stem Packing	PTFE
11	Nut	Brass
12	Olive	Brass

Dimensions in mm

This data sheet is designed as a guide and should not be regarded as wholly accurate in every detail. We reserve the right to amend the specification of any product without notice.

PN40 Brass Ball Valve

Features

- Screwed BSP Parallel (ISO 228/1)
- PTFE Seats & Seals
- ISO 5211 Direct Mount
- Low Torque

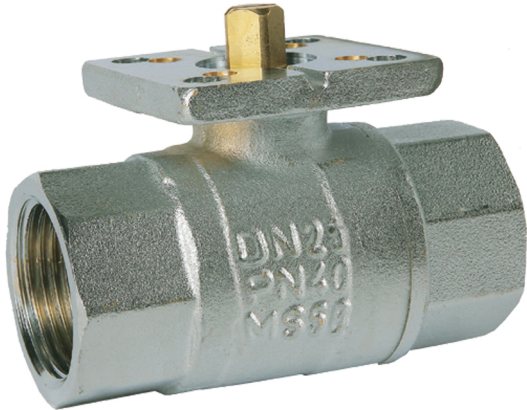

Pressure / Temperature

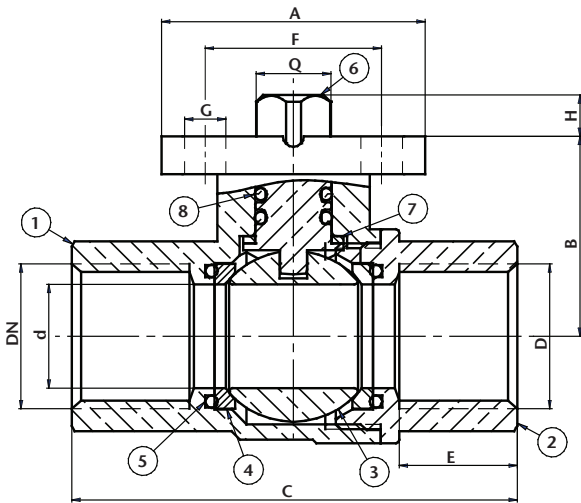
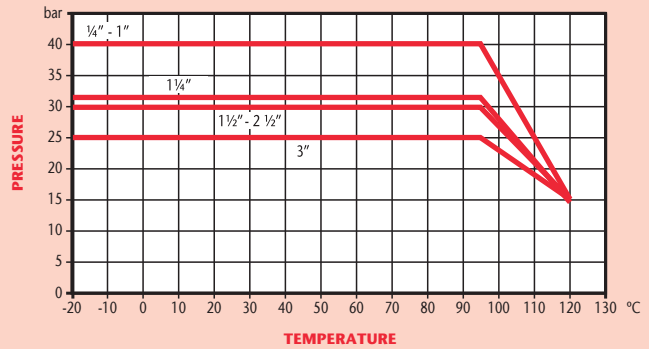

DN	1/4"	3/8"	1/2"	3/4"	1"	1 1/4"	1 1/2"	2"	2 1/2"	3"
d	11.5	15	15	20	25	32	38	45	62	76
A	38	38	38	38	50	50	50	50	70	70
B	29	29	29	32	36	41	57	64	90	100
C	64	64	64	76	88	96	103	121	165	188
G	6	6	6	6	7	7	7	7	8.5	8.5
E	17	17	17	19	21	22	22	25	34	37
F	36	36	36	36	50	50	50	50	70	70
Drilling	F03	F03	F03	F03	F05	F05	F05	F05	F07	F07
Q	9	9	9	9	9	9	11	11	14	14
H	10	10	10	10	10	10	12	12	16	16
Torque	3	3	3	4	5	10	15	15	20	20
Kgs	0.335	0.315	0.280	0.410	0.705	0.950	1.160	2.055	3.850	5.515

Torque calculated at zero pressure includes 25% safety, add 25% for dry duty.

Technical Data

Max Pressure	1/4"-1"	40 Bar
	1 1/4"	32 Bar
	1 1/2"-2 1/2"	30 Bar
	3"	25 Bar
Working Temperature	-20°C to +120°C	

N.	Part Name	Materials
1	Body	Brass/Nickel Plated
2	Body End	Brass/Nickel Plated
3	Ball	Brass/Chrome Plated
4	Seat	PTFE
5	'O' Ring	PTFE
6	Stem	Brass/Nickel Plated
7	Washer	PTFE
8	'O' Ring	Viton

Dimensions in mm

This data sheet is designed as a guide and should not be regarded as wholly accurate in every detail. We reserve the right to amend the specification of any product without notice.

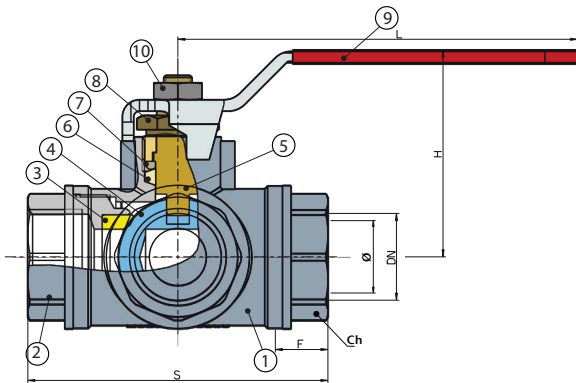
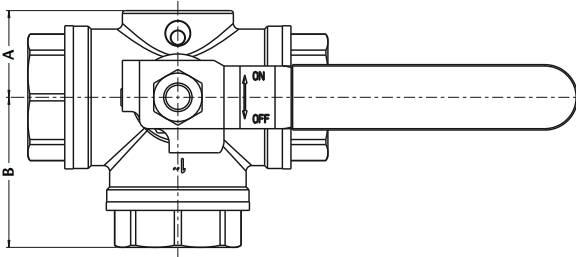

PN32 Brass 3 Way Ball Valve

Features

- Screwed BSP Parallel (ISO 228/1)
- PTFE Seats & Seals
- Reduced Bore
- 'L' & 'T' Port

Pressure / Temperature

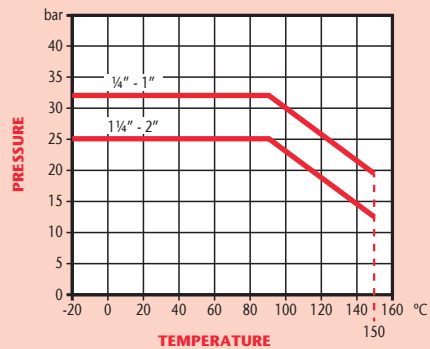

DN	1/4"	3/8"	1/2"	3/4"	1"	1 1/4"	1 1/2"	2"
S	74	74	80	90	105	115	138	161
H	58	58	60	64	73	79	100	105
B	37	37	39	46	52	58	69	80
A	22	22	24	28	31	35	42	48
F	12	12	14	16	19	21	23	26
Ch	22	22	29	34	42	50	57	68
L	90	90	125	125	140	140	220	220
ø	10	10	12	15	20	25	32	40
Kgs	0.69	0.73	0.82	1.04	1.74	2.70	4.32	8.37

N.	Part Name	Materials
1	Body	Brass/Nickel Plated
2	Body End	Brass/Nickel Plated
3	Seat	PTFE
4	Ball	Brass/Chrome Plated
5	Stem	Brass
6	Stem Seat	PTFE
7	Packing Nut	Brass
8	Lever	Steel/PVC Coated
9	Nut	Steel/Zinc Plated

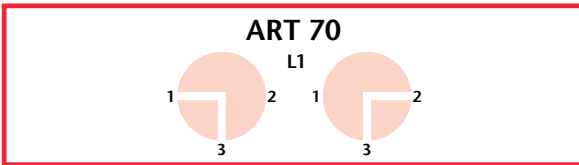

Ball Positions

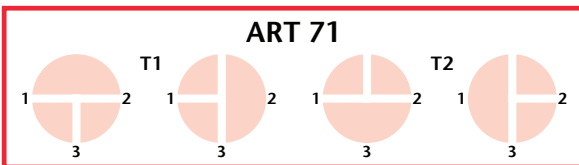

Ball Positions

Technical Data

Max Pressure	1/4"-1"	32 Bar
	1/4"-2"	25 Bar
Working Temperature	-20°C to +150°C	

Dimensions in mm

This data sheet is designed as a guide and should not be regarded as wholly accurate in every detail. We reserve the right to amend the specification of any product without notice.

PN30 Brass 3 Way Ball Valve

Features

- Screwed BSP Parallel (ISO 228/1)
- PTFE Seals
- ISO 5211 Direct Mount
- Levers Available
- 'T' & 'L' Port

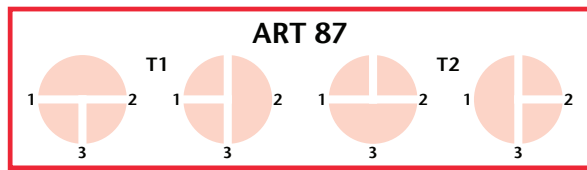
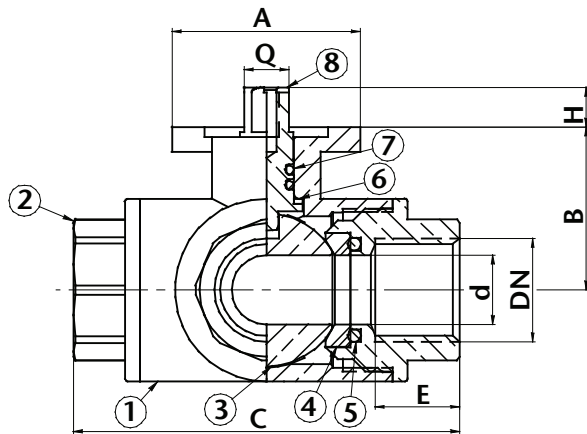

Ball Positions

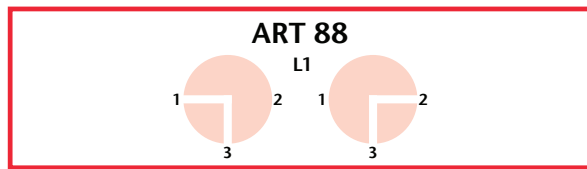

Ball Positions

Technical Data		
Max Pressure	1/4" - 3/4"	30 Bar
	1" - 1 1/4"	20 Bar
	1 1/2" - 2"	16 Bar
Working Temperature	-20°C to +120°C	

Dimensions in mm

This data sheet is designed as a guide and should not be regarded as wholly accurate in every detail. We reserve the right to amend the specification of any product without notice.

Pressure / Temperature

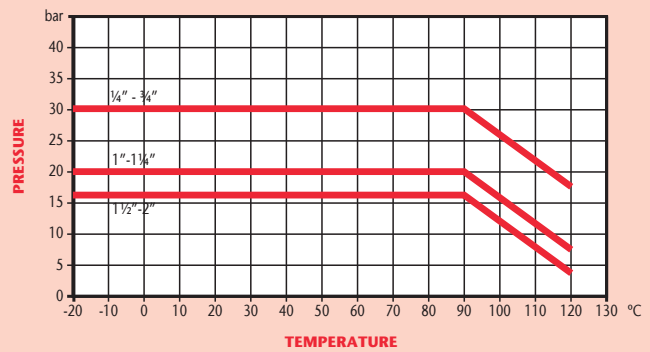

DN	1/4"	3/8"	1/2"	3/4"	1"	1 1/4"	1 1/2"	2"
d	10	10	14	19	24	30	38	48
A	38	38	38	50	50	50	70	70
B	30	30	33	42	47	52	70	79.5
C	65	65	78	87	105	118	134	161
E	15	15	17	18	21	23.5	23.5	27.5
H	10	10	10	12	12	12	16	16
Q	9	9	9	11	11	11	14	14
ISO5211	F03	F03	F03	F05	F05	F05	F07	F07
Torque	3	3	4	10	13	13	20	25
Kgs (ART 87)	0.42	0.39	0.57	0.88	1.47	1.99	3.64	6.15
Kgs (ART 88)	0.42	0.39	0.57	0.90	1.49	2.05	3.73	6.29

Torque calculated at zero pressure includes 25% safety, add 25% for dry duty.

N.	Part Name	Materials
1	Body	Brass/Chrome Plated
2	Body End	Brass/Chrome Plated
3	Ball	Brass/Chrome Plated
4	Ring	PTFE
5	'O' Ring	Viton
6	Washer	PTFE
7	'O' Ring	Viton
8	Stem	Brass/Nickel Plated



PN25 Brass Gate Valve

Features

- Screwed BSP Taper (ISO 7/1)
- Full Bore
- BS5154
- Kite Marked KM553179

Pressure / Temperature

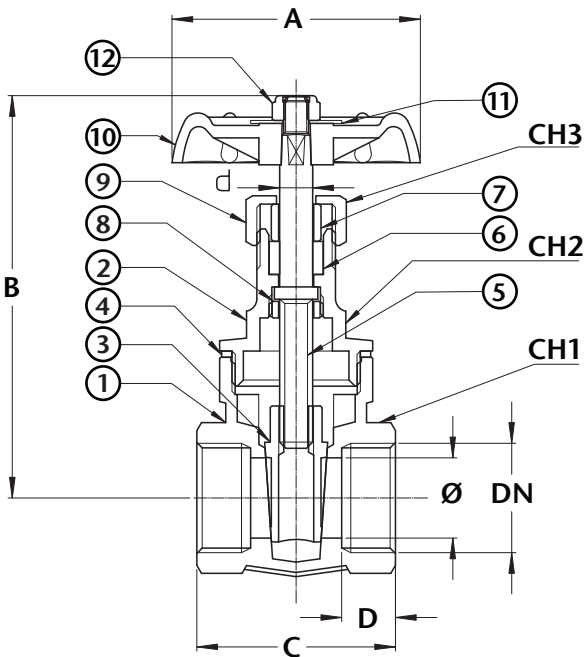
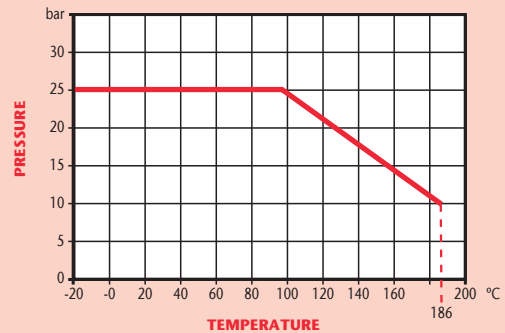

Technical Data

Max Pressure	25 Bar
Working Temperature	-10°C to +186°C

Dimensions in mm

This data sheet is designed as a guide and should not be regarded as wholly accurate in every detail. We reserve the right to amend the specification of any product without notice.

DN	1/2"	3/4"	1"	1 1/4"	1 1/2"	2"	2 1/2"	3"	4"
ø	13	19.4	26	32	38.5	50.4	64	77	102
A	55	60	65	75	80	90	120	140	175
B	80	97	108	122	142	166	212	248	297
C	44	48	55	61	65	71	92	98	107
D	12	13	15.5	16.5	18	19	24	26	28
CH1	27	33	40	50	56	69	85	100	130
CH2	22	24	26	32	42	52	60	80	110
CH3	19	21	21	25	25	29	33	37	45
d	8	8	9	10	11	12	16	17	19
Kgs	0.26	0.39	0.53	0.81	1.15	1.80	3.52	5.33	8.96

N.	Part Name	Materials
1	Body	Brass
2	Bonnet	Brass
3	Wedge	Brass
4	Packing	Graphite
5	Stem	Brass
6	Gasket	PTFE
7	Gland Screw	Brass
8	Cap	Brass
9	Nut	Brass
10	Handwheel	Steel
11	Plate	Aluminium
12	Self-Locking Nut	Steel

PN20 Brass Gate Valve

Features

- Screwed BSP Taper (ISO 7/1)
- Brass Body & Wedge
- BS5154



Pressure / Temperature

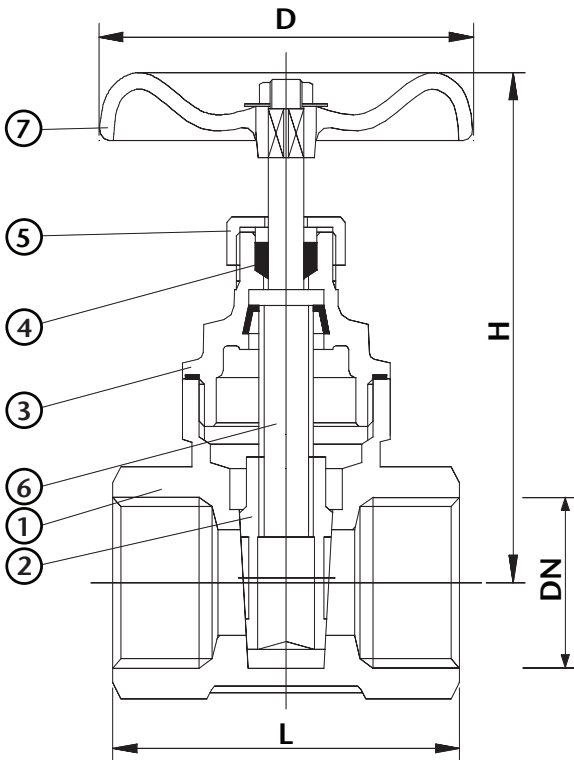
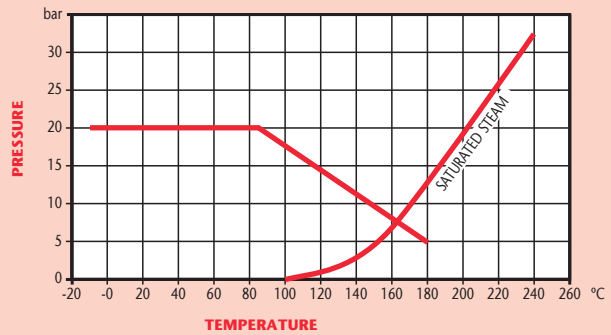

DN	1/2"	3/4"	1"	1 1/4"	1 1/2"	2"	2 1/2"	3"	4"
L	43	46	52	65	66	82.5	94	103	119.5
H	72.1	76.7	87.6	103	113.7	147.7	163.5	190	235
D	55	55	60	72	72	80	100	110	130
Kgs	0.25	0.31	0.42	0.71	0.92	1.42	2.55	3.22	5.76

Technical Data

Max Pressure	20 Bar
Working Temperature	-10°C to +180°C

N.	Part Name	Materials
1	Body	Brass
2	Wedge	Brass
3	Bonnet	Brass
4	Stem Packing	PTFE
5	Gland nut	Brass
6	Stem	Brass
7	Handwheel	Cast Iron

Dimensions in mm

This data sheet is designed as a guide and should not be regarded as wholly accurate in every detail. We reserve the right to amend the specification of any product without notice.

PN16 Brass Gate Valve

Features

- Screwed BSP Parallel
- Brass Body & Wedge

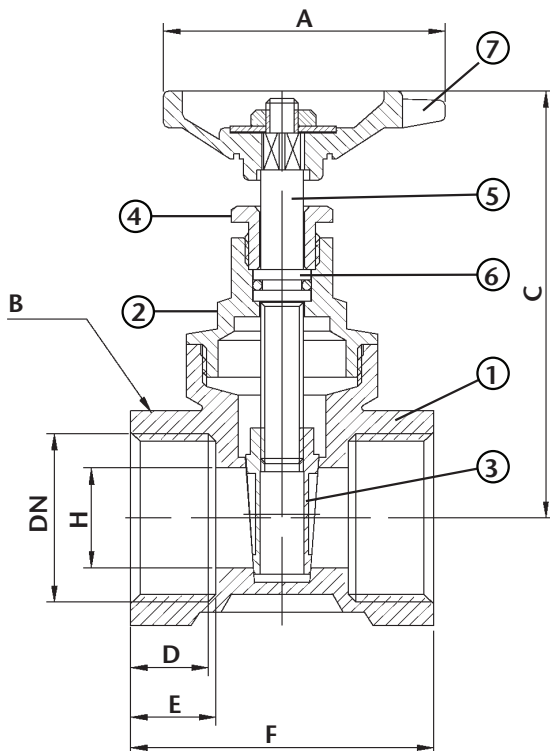

Pressure / Temperature

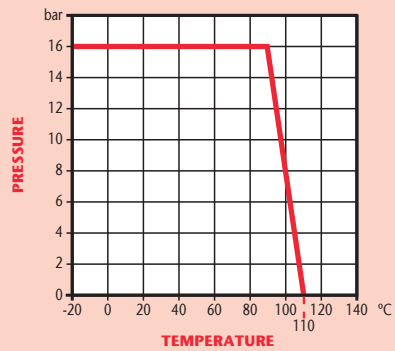

DN	1/4"	3/8"	1/2"	3/4"	1"	1 1/4"	1 1/2"	2"
A	55	55	55	55	60	70	70	80
B	24	24	24	31	37	47	54.5	65
C	65	65	65	66	70	98	10.5	122
D	10	10	10.5	11	12	12	14	14
E	11	11	11	11.5	12.5	13	15	15
F	39	39	39	41	47	51	58	58
H	11	12	13	15	19	25	31	37
Kgs	0.15	0.15	0.20	0.26	0.36	0.53	0.73	0.96

Technical Data

Max Pressure	16 Bar
Working Temperature	-20°C to +110°C

N.	Part Name	Materials
1	Body	Brass
2	Body End	Brass
3	Wedge	Brass
4	Gland nut	Brass
5	Stem	Brass
6	Stem Packing	PTFE
7	Handwheel	Cast Iron

Dimensions in mm

This data sheet is designed as a guide and should not be regarded as wholly accurate in every detail. We reserve the right to amend the specification of any product without notice.

PN16 Brass Gate Valve

Features

- Compression Ends
- Brass Body & Wedge
- BS5154

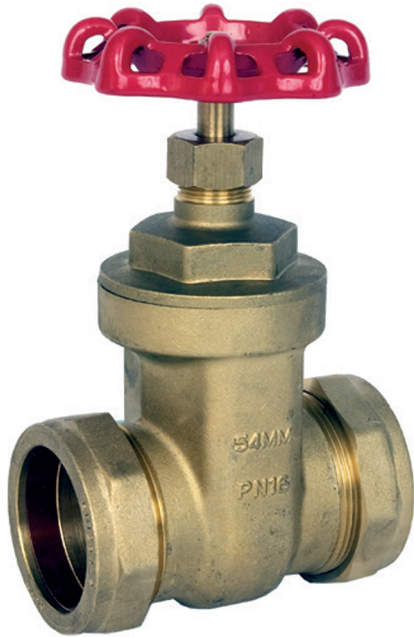

Pressure / Temperature

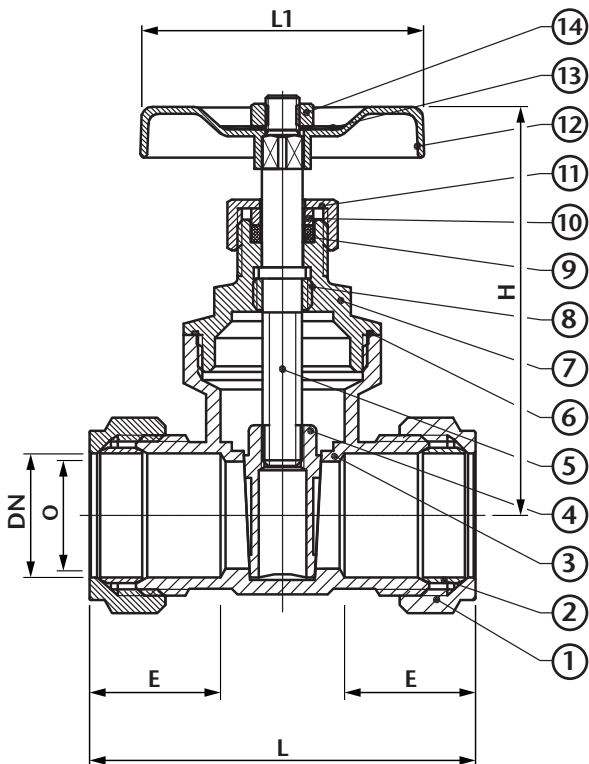
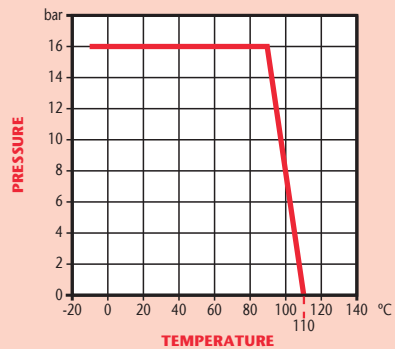

DN	15	22	28	35	42	54
O	13	19	25.5	32	38	80
E	20	24	24.5	33	33	40
L	60	68	77	93	97	116
L1	50	50	58	77	77	100
H	66	72	87	132	134	164

N.	Part Name	Materials
1	Compression Nut	Brass
2	Olive	T2
3	Body	Brass
4	Wedge	Brass
5	Stem	Brass
6	Seat	PTFE
7	Bonnet	Brass
8	Lock Ring	Brass
9	Packing	PTFE
10	Packing Gland Washer	Brass
11	Packing Gland Nut	Brass
12	Handle Wheel	Iron
13	Name Plate	Aluminium
14	Nut	Brass/Copper Plated

Technical Data

Max Pressure	16 Bar
Working Temperature	-10°C to +110°C

Dimensions in mm

This data sheet is designed as a guide and should not be regarded as wholly accurate in every detail. We reserve the right to amend the specification of any product without notice.

PN20 Brass Y Strainer

Features

- Screwed BSP Parallel (ISO 228/1)
- Brass Body
- Stainless Steel Mesh



Pressure / Temperature

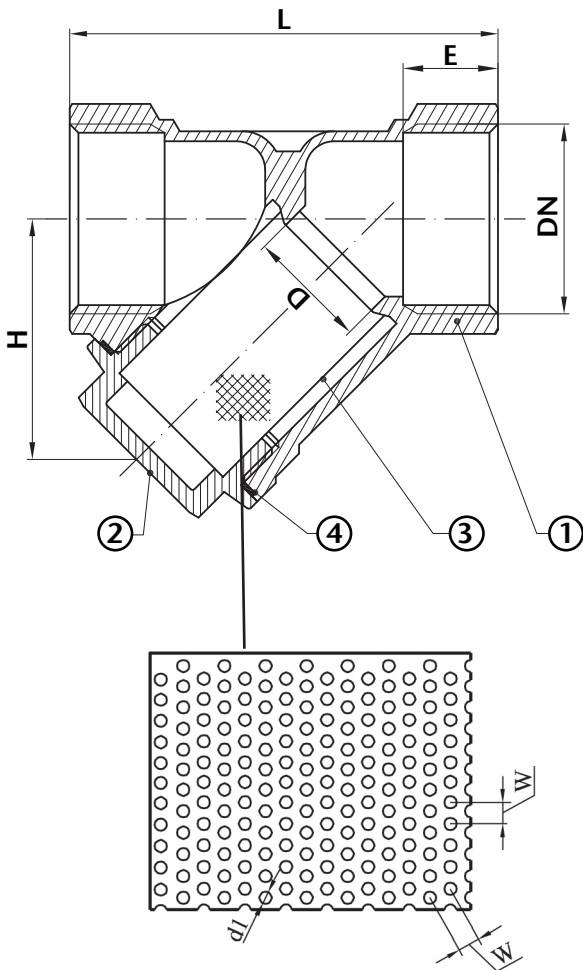
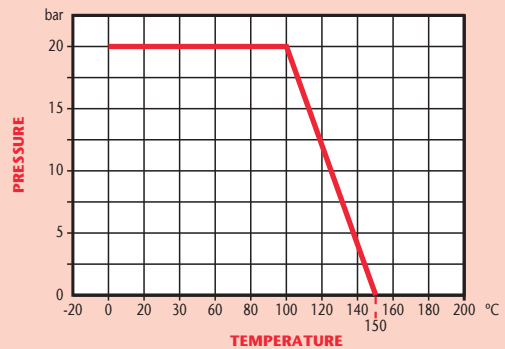

DN	1/2"	3/4"	1"	1 1/4"	1 1/2"	2"	2 1/2"	3"	4"
L	57	72	74.5	95	105	129	142.5	160	245
H	34.5	39.5	43	54	61.5	61.5	83	93	143
E	12.5	15	16.5	18	18	20	20	22	30
D	15	18.5	21	29	38	46	58	64	100
d1	0.60	0.84	0.84	0.84	0.84	0.84	0.84	0.84	0.84
W	0.9	1.3	1.3	1.3	1.3	1.3	1.3	1.3	1.3
Kgs	0.16	0.28	0.35	0.62	0.83	1.20	1.98	3.03	7.00

Technical Data

Max Pressure	20 Bar
Working Temperature	0°C to +150°C

N.	Part Name	Materials
1	Body	Brass
2	Bonnet	Brass
3	Strainer	Stainless Steel 304
4	Gasket	PTFE

Dimensions in mm

This data sheet is designed as a guide and should not be regarded as wholly accurate in every detail. We reserve the right to amend the specification of any product without notice.

PN20 Brass Swing Check Valve

Features

- Screwed BSP Parallel (ISO 228/1)
- Brass Body
- Metal Seat



Pressure / Temperature

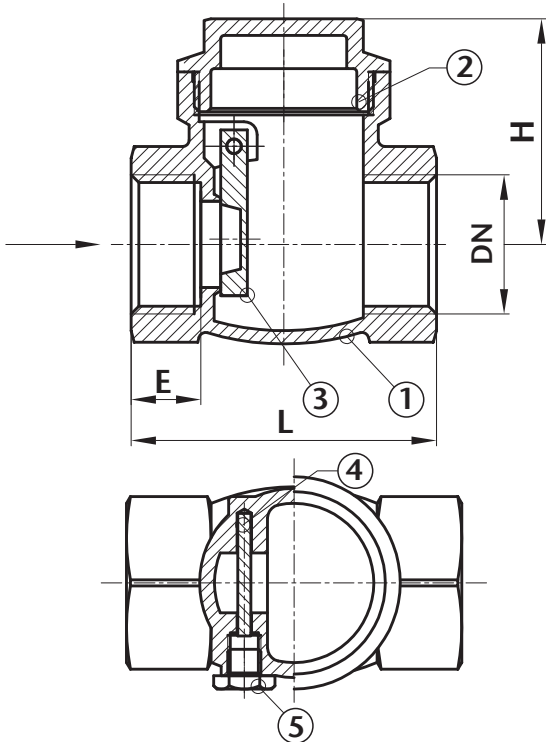
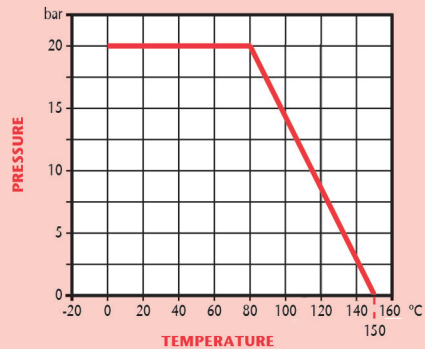

DN	1/2"	3/4"	1"	1 1/4"	1 1/2"	2"	2 1/2"	3"	4"
L	46	56	63.5	67.5	82	94	105	126.5	159
H	34	37.5	44.5	50	56.5	65.5	77	82	103
E	10.5	13.5	14.5	14	17	19	21	23.5	27.5
D	13	18	22	29	33	42.5	50	62	83
Kgs	0.15	0.22	0.35	0.53	0.74	1.17	1.81	2.43	4.9

Technical Data

Max Pressure	20 Bar
Working Temperature	0°C to 150°C

N.	Part Name	Materials
1	Body	Brass CW617N
2	Bonnet	Brass CW617N
3	Disc	Brass CW617N
4	Pin	Stainless Steel 304
5	Plug	Brass

Dimensions in mm

This data sheet is designed as a guide and should not be regarded as wholly accurate in every detail. We reserve the right to amend the specification of any product without notice.

PN20 Brass Swing Check Valve

Features

- Screwed BSP Parallel (ISO 228/1)
- Brass Body
- NBR Rubber Seat

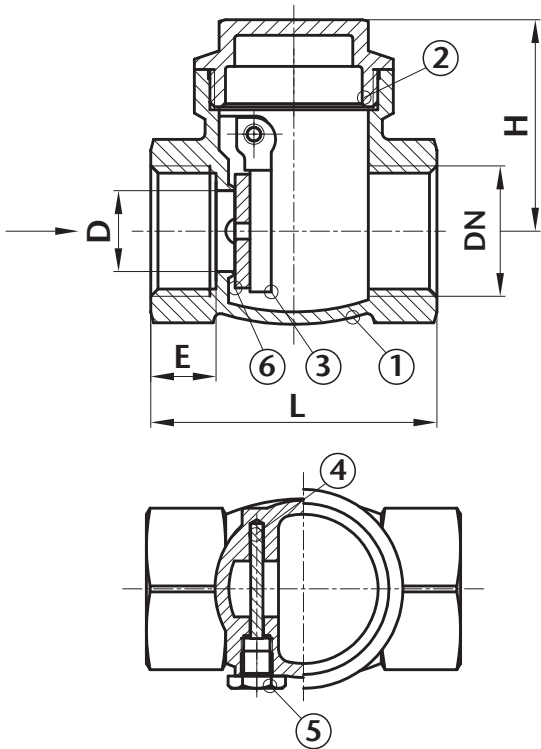

Pressure / Temperature

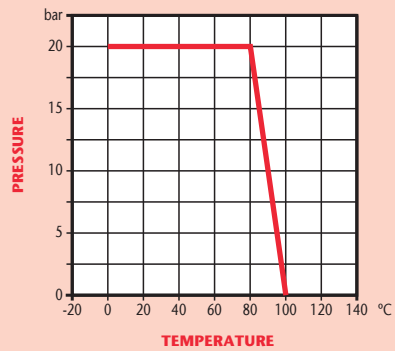

DN	1/2"	3/4"	1"	1 1/4"	1 1/2"	2"	2 1/2"	3"	4"
L	46	56	63	67.5	82	94	106	126.5	159
H	34	37.5	44.5	50	56.5	64.5	76	82	103
E	10.5	13.5	14.5	14.5	17	19	19	23.5	27.5
D	13	18	22	29	33	42	47	62	83
Kgs	0.15	0.22	0.34	0.52	0.75	1.14	1.83	2.44	4.93

Technical Data

Max Pressure	20 Bar
Working Temperature	0°C to +100°C

N.	Part Name	Materials
1	Body	Brass
2	Bonnet	Brass
3	Disc	Brass
4	Pin	Stainless Steel 304
5	Plug	Brass
6	Sealing Ring	NBR

Dimensions in mm

This data sheet is designed as a guide and should not be regarded as wholly accurate in every detail. We reserve the right to amend the specification of any product without notice.

PN20 Brass Spring Check Valve

Features

- Screwed BSP Parallel (ISO 228/1)
- Brass Body
- Brass Disc
- NBR Seat

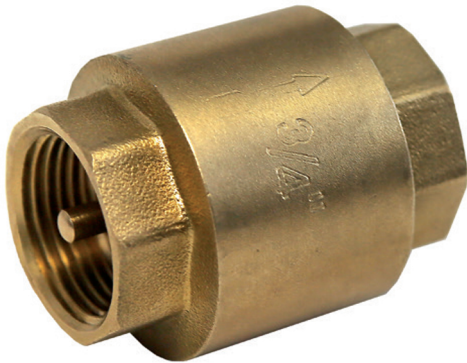

Pressure / Temperature

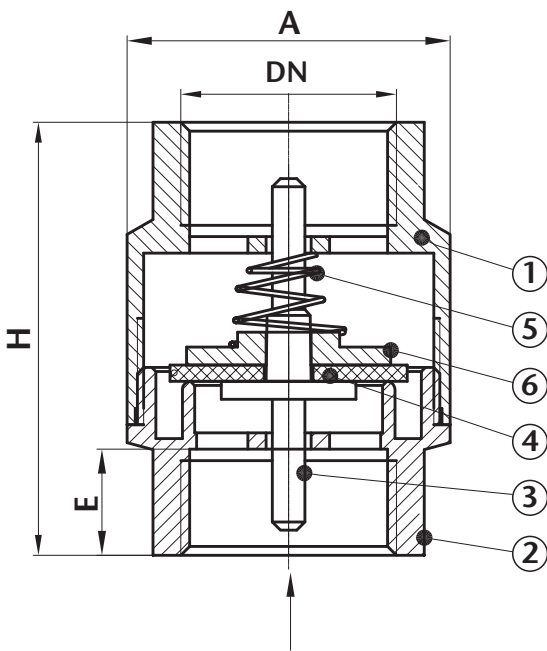
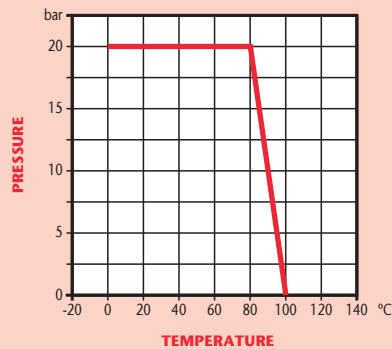

DN	3/8"	1/2"	3/4"	1"	1 1/4"	1 1/2"	2"	2 1/2"	3"	4"
A	32.5	33	39	45	55	60	79	95	110	143
H	44.5	47	49	58	65	70	83	100	107	111
E	11	12	14	14.5	14.5	16	18.5	22	24	24
Kgs	0.14	0.13	0.18	0.26	0.40	0.59	0.84	1.50	1.92	3.05

Technical Data

Max Pressure	20 Bar
Working Temperature	0°C to +100°C

N.	Part Name	Materials
1	Body	Brass
2	Bonnet	Brass
3	Disc Holder	Brass
4	Disc	Brass / NBR
5	Spring	Stainless Steel 304
6	Spring Holder	Brass

Dimensions in mm

This data sheet is designed as a guide and should not be regarded as wholly accurate in every detail. We reserve the right to amend the specification of any product without notice.



Foot Valve

Features

- PN20 Brass Spring Check Valve with Stainless Steel Mesh Filter
- Screwed BSP Parallel (ISO 228/1)
- Check Valve has Brass Body and Brass Disc
- NBR Seat

Check Valve

DN	1/2"	3/4"	1"	1 1/4"	1 1/2"	2"	2 1/2"	3"	4"
A	33	39	45	55	60	79	95	110	143
H	47	49	58	65	70	83	100	107	111
E	12	14	14.5	14.5	16	18.5	22	24	24
Kgs	0.13	0.18	0.26	0.40	0.59	0.84	1.50	1.92	3.05

N.	Part Name	Material
1	Body	Brass
2	Bonnet	Brass
3	Disc Holder	Brass
4	Disc	Brass / NBR
5	Spring	Stainless Steel 304
6	Spring Holder	Brass

Check Valve

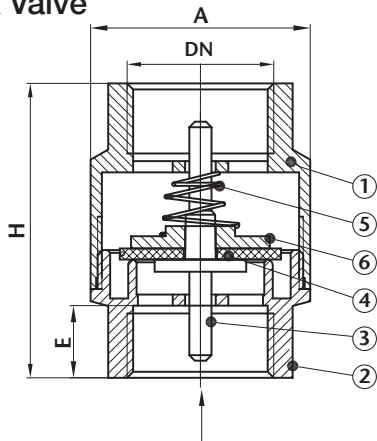

Mesh Filter

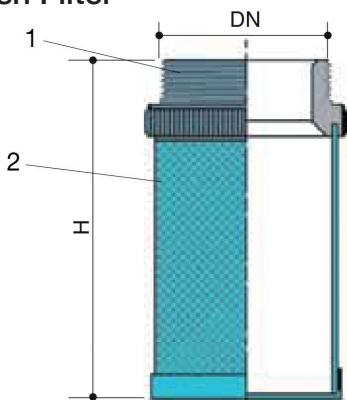

Mesh Filter

DN	1/2"	3/4"	1"	1 1/4"	1 1/2"	2"	2 1/2"	3"	4"
H	57	56	59	67	68	89	97	107	119
nr.holes/cm ²	24	24	24	24	24	24	24	24	24
Hole area	1.1 ²	1.1 ²	1.1 ²	1.1 ²	1.1 ²	1.1 ²	1.1 ²	1.1 ²	1.1 ²
D	2.6	2.6	2.6	2.6	2.6	2.6	2.6	2.6	2.6
ØF	0.85	0.85	0.85	0.85	0.85	0.85	0.85	0.85	0.85
Kgs	0.03	0.04	0.07	0.09	0.10	0.20	0.23	0.32	0.49

N.	Part Name	Material
1	Mesh Filter	Stainless Steel
2	Connection	Nylon

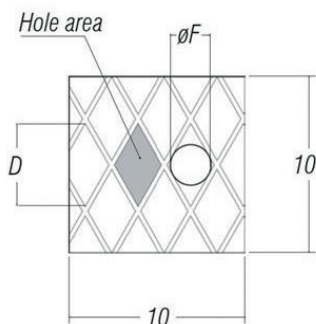

Technical Data

Max Pressure	1/2" - 1"	16 Bar
	1 1/4" - 2"	10 Bar
	2 1/2" - 4"	8 Bar
Working Temperature	0°C to +90°C	

Dimensions in mm

This data sheet is designed as a guide and should not be regarded as wholly accurate in every detail. We reserve the right to amend the specification of any product without notice.

ART 1837 Check Valve for Automatic Air Vent

Features

- Screwed BSP Parallel M/F Ends
- Body Brass CW617N Nickel Plated

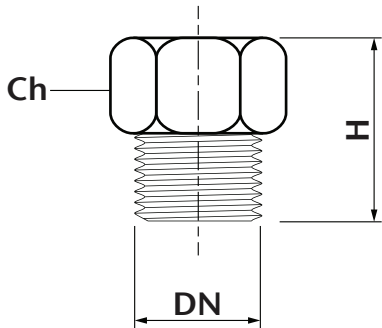

DN	3/8"	1/2"
H	25	25
Ch	19	23
Kgs	0.02	0.04

Technical Data

Max Pressure	10 Bar
Working Temperature	5°C to 110°C

ART 1360 Automatic Air Vent

Features

- Screwed BSP Parallel Male End
- Body Brass CW617N Nickel Plated

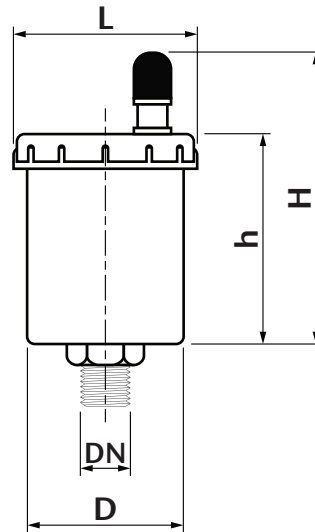

DN	3/8"	1/2"
D	39	39
H	61	61
h	46	46
L	47	47
Kgs	0.15	0.16

Technical Data

Max Pressure	10 Bar
Working Temperature	5°C to 110°C

Dimensions in mm

This data sheet is designed as a guide and should not be regarded as wholly accurate in every detail. We reserve the right to amend the specification of any product without notice.

ART 97 Thermal Extension

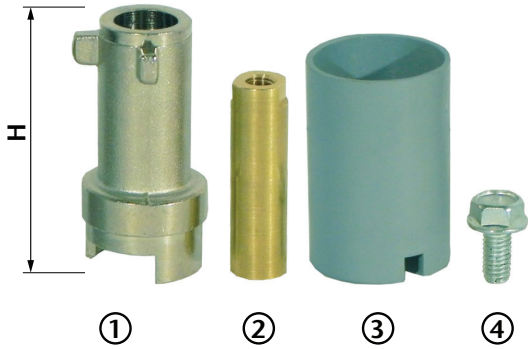

DN	1/4"	3/8"	1/2"	3/4"	1"	1 1/4"	1 1/2"	2"	2 1/2"	3"	4"
Art 45T	M	M	1A	1A	2A	2A	3A	3A	5A	5A	5A
Art 45P	M	M	1A	1A	2A	2A	3A	3A	5A	5A	5A
Art 70/71	T1A	T1A	T2A	T2A	T3A	T3A	T4A	T4A			

	M	1A	2A	3A	4A	5A
H	50	55	65	75	90	100

N.	Part Name	Materials
1	Extension	Brass/Nickel Plated
2	Stem	Brass
3	Fix Cover	Plastic
4	Screw	Steel

ART 97C Thermal Extension

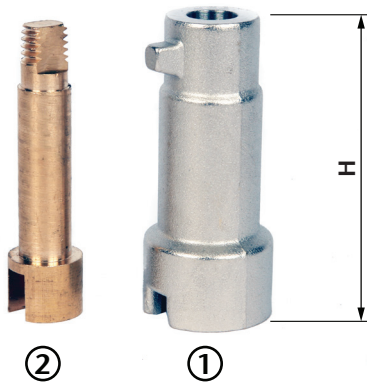

DN	1/2" - 15mm	3/4" - 22mm	1" - 28mm	1 1/4" - 35mm	1 1/2" - 42mm	2" - 54mm
Art 40	1B	1B	2B	3B	3B	4B
Art 89	1B	1B	2B	3B	3B	4B
Art 50	1B	1B	2B	3B	3B	4B
Art 59	1B	1B	2B	3B	3B	4B

	1B	2B	3B	4B
H	55	65	75	85

N.	Part Name	Materials
1	Extension	Brass/Nickel Plated
2	Stem	Brass

ART 97I Thermal Extension for ART 55PRS



	15 & 22mm	28 & 35mm	42 & 54mm
DN	M.6	M.8	M.10
A	18.5	26	32
B	63.5	65.5	68.5
B1	64	64	68
Kgs	0.08	0.10	0.15

N.	Part Name	Materials
1	Extension	Aluminium Alloy EN AB-46100
2	Stem	Brass CW617N-M
3	O-Ring	PTFE

Dimensions in mm

This data sheet is designed as a guide and should not be regarded as wholly accurate in every detail. We reserve the right to amend the specification of any product without notice.

ART 257 Locking Device for ART 45 & ART 257C for ART 40, 50, 59, 89 Ball Valve Series

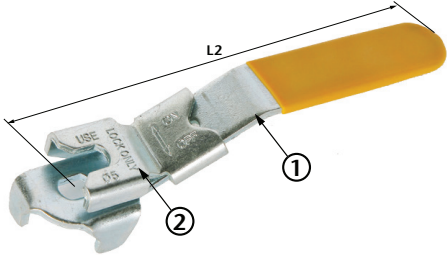

ART 257

DN	Choice of Handle							
	1/4"	3/8"	1/2"	3/4"	1"	1 1/4"	1 1/2"	2"
45-46-47	M	M	1A	1A	2A	2A	3A	3A
L2	M		1A		2A		3A	
	95		120		150		160	

ART 257C

DN	Choice of Handle					
	1/2"-15mm	3/4"-22mm	1"-28mm	1 1/4"-35mm	1 1/2"-42mm	2"-54mm
40-50-59-89	C1	C1	C2	C3	C3	C4
L2	C1	C2	C3	C4		
	100	125	150	165		

N.	Part Name	Materials
1	Handle	Steel/Nickel Plated
2	Slide Device	Steel/Nickel Plated

ART 96 Extended Tee Handle



DN	1/2" - 15mm	3/4" - 22mm	1" - 28mm
Art 40	1B	1B	2B
Art 89	1B	1B	2B
Art 50	1B	1B	2B
Art 59	1B	1B	2B

	1/2" - 15mm	3/4" - 22mm	1" - 28mm
L	84	84	102
H	54	54	64

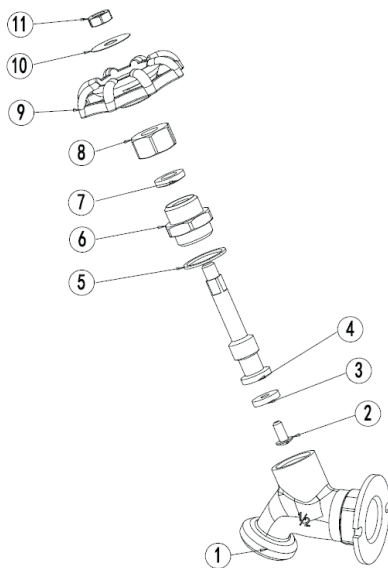
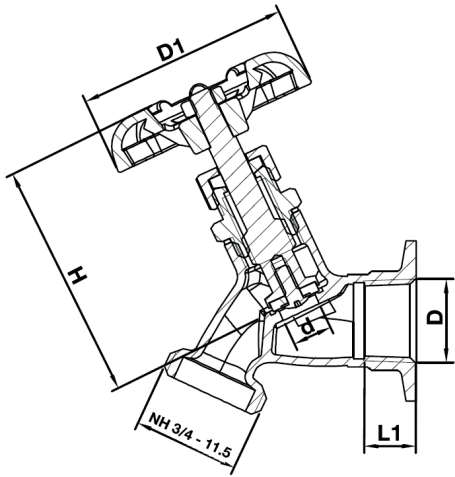

Lead Free Brass Hose Bib Taps

Features

- Female Threads NPT (ANSI B1.20.1)
- Male Threads 3/4" NHT

Pressure / Temperature

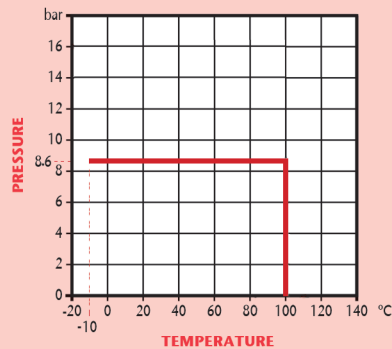

D	1/2"	3/4"
D1	53	53
d	10	10
L1	13.5	13.5
H	60.2	60.2
Kgs	0.21	0.23

N.	Part Name	Materials
1	Body	Lead Free Brass C46500
2	Screw	Brass
3	Gasket	EPDM
4	Stem	Lead Free Brass C46500
5	Gasket	PTFE
6	Bonnet	Lead Free Brass C46500
7	Gasket	EPDM
8	Nut	Brass
9	Handwheel	Cast Iron
10	Gasket	Aluminium
11	Nut	Steel Q235

Technical Data

Max Pressure	125psi (8.6 Bar)
Working Temperature	-10°C to +100°C

Dimensions in mm

This data sheet is designed as a guide and should not be regarded as wholly accurate in every detail. We reserve the right to amend the specification of any product without notice.



Lead Free Brass Vacuum Breaker

Features

- Male / Female NHT Threads
- Conforms to ANSI A1 12.1.13 ASSE standard 1011
- Anti tamper screw
- Manual drain feature

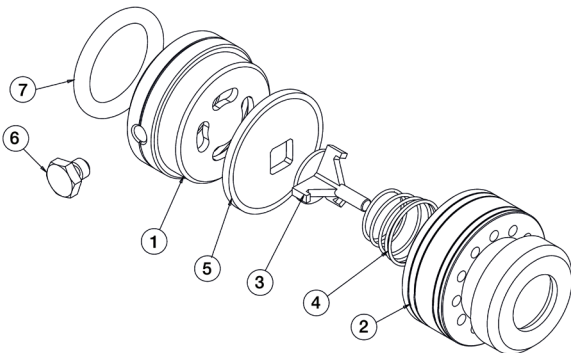
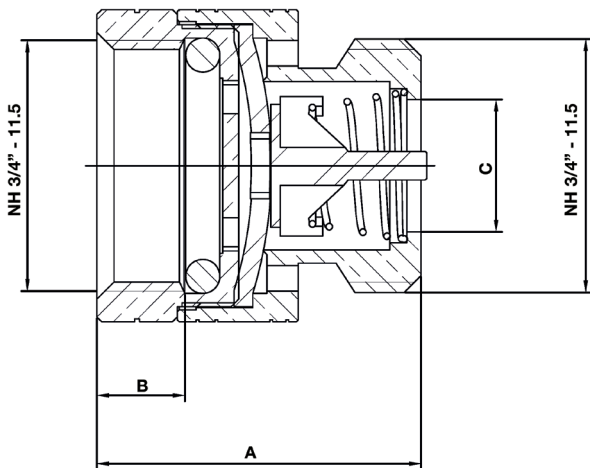

Pressure / Temperature

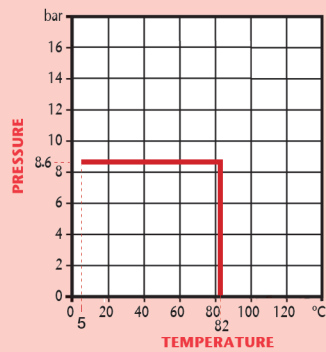

DN	3/4"
A	34.3
B	9.3
C	14.0
Kgs	0.11

N.	Part Name	Materials
1	Body	Lead Free Brass C46500
2	Bonnet	Lead Free Brass C46500
3	Core	POM
4	Spring	Stainless Steel
5	Gasket	NBR
6	Screw	Brass
7	O-Ring	NBR

Technical Data

Max Pressure	125psi (8.6 Bar)
Max Temperature	+5°C to +82°C

Dimensions in mm

This data sheet is designed as a guide and should not be regarded as wholly accurate in every detail. We reserve the right to amend the specification of any product without notice.



Brass Drain Cock

Features

- Screwed Male BSP Parallel (ISO 228/1)
- BS 2879/2 Type A
- Hose connection outlet
- WRAS Approved

Pressure / Temperature

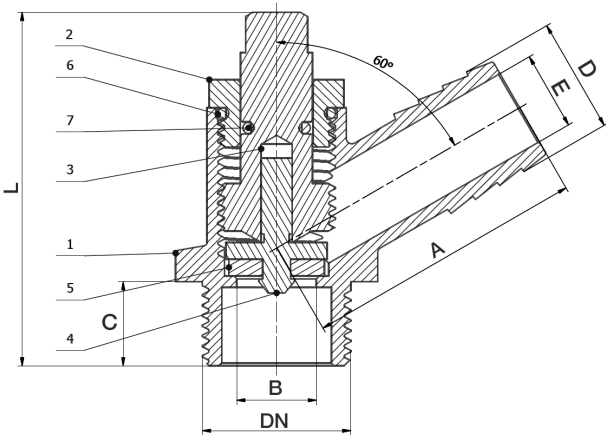
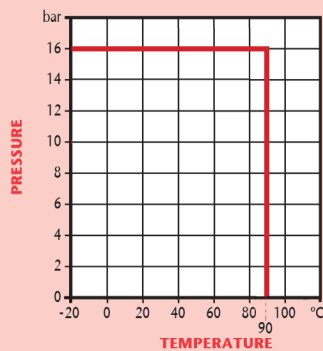

DN	1/2"	3/4"
A	32.5	50
B	Ø9.5	Ø14.2
C	12.5	15
D	Ø14	Ø20.5
E	Ø9.5	Ø14
L	45-49.5	63-69.5
Kgs	0.08	0.21

N.	Part Name	Materials
1	Body	Brass
2	Bonnet	Brass
3	Stem	Brass
4	Baffle	Brass
5	Washer	EPDM
6	O-Ring	EPDM
7	O-Ring	EPDM

Technical Data	
Max Pressure	16 Bar
Max Temperature	-20°C to +90°C

Dimensions in mm
 This data sheet is designed as a guide and should not be regarded as wholly accurate in every detail. We reserve the right to amend the specification of any product without notice.



Brass Drain Cock

Features

- Male spigot
- BS 2879/2 Type A
- Hose connection outlet
- WRAS Approved

Pressure / Temperature

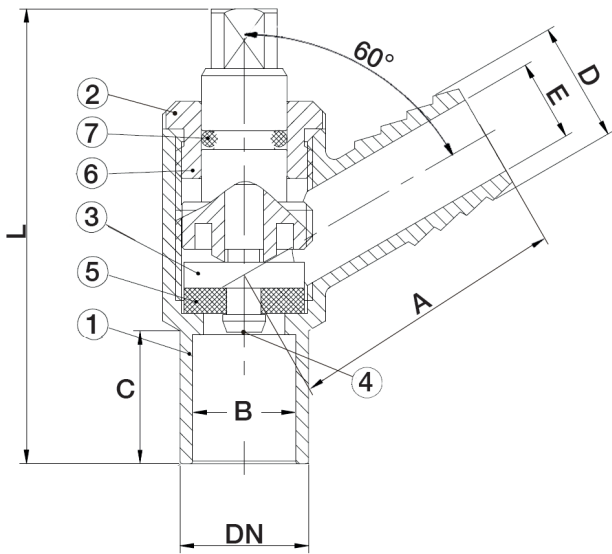
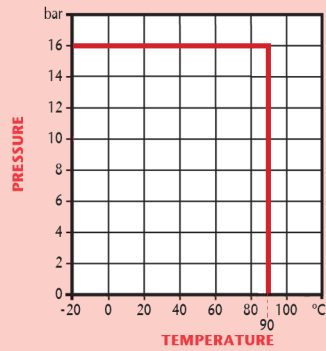

DN	15
A	35
B	Ø9.5
C	15.5
D	Ø14
E	Ø9.7
L	51.5-56.0
Kgs	0.07

N.	Part Name	Materials
1	Body	Brass - HPb59-T
2	Bonnet	Brass - HPb59-T
3	Stem	Brass - HPb59-T
4	Baffle	Brass - HPb59-T
5	Washer	EPDM
6	Lock Nut	Brass - HPb59-T
7	O-Ring	EPDM

Technical Data

Max Pressure	16 Bar
Max Temperature	-20°C to +90°C

Dimensions in mm

This data sheet is designed as a guide and should not be regarded as wholly accurate in every detail. We reserve the right to amend the specification of any product without notice.



Brass Drain Cock

Features

- Extended male spigot
- BS 2879/2 Type A
- Hose connection outlet
- WRAS Approved



Pressure / Temperature

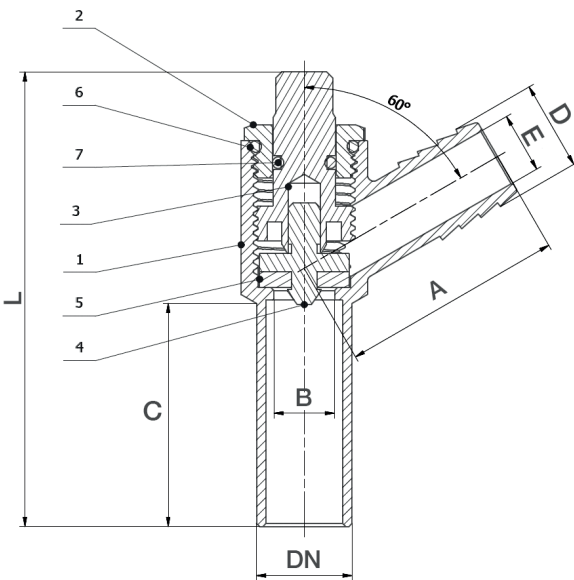
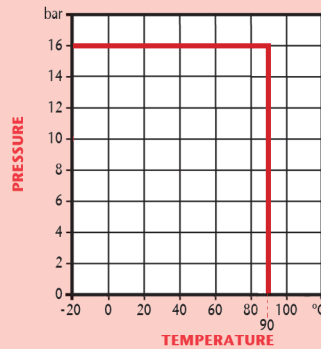

DN	15
A	35
B	Ø9.5
C	35
D	Ø14
E	Ø9.5
L	71.3-75.8
Kgs	0.09

Technical Data

Max Pressure	16 Bar
Max Temperature	-20°C to +90°C

N.	Part Name	Materials
1	Body	Brass - HPb59-T
2	Bonnet	Brass - HPb59-T
3	Stem	Brass - HPb59-T
4	Baffle	Brass - HPb59-T
5	Washer	EPDM
6	O-Ring	EPDM
7	O-Ring	EPDM

Dimensions in mm

This data sheet is designed as a guide and should not be regarded as wholly accurate in every detail. We reserve the right to amend the specification of any product without notice.



Compression Isolation Valve

Features

- Compression ends in accordance with BS EN1254-2
- WRAS Approved

Pressure / Temperature

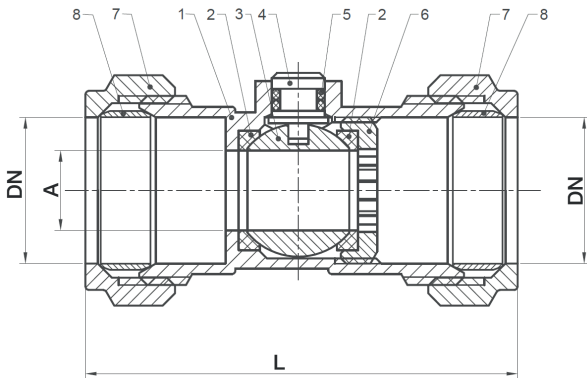
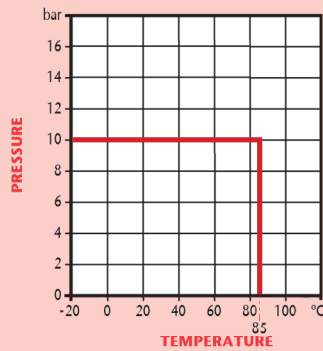

DN	15	22
A	Ø8	Ø12
L	50	65
Kgs	0.07	0.16

Technical Data

Max Pressure	10 Bar
Max Temperature	-20°C to +85°C

N.	Part Name	Materials
1	Body	Brass Nickel Plated
2	Sealing Ring	Silicone
3	Ball	Brass Chrome Plated
4	Stem	Brass
5	O-Ring	EPDM
6	Pressure Cap	Brass
7	Cap	Brass Nickel Plated
8	Olive	Copper

Dimensions in mm

This data sheet is designed as a guide and should not be regarded as wholly accurate in every detail. We reserve the right to amend the specification of any product without notice.

Brass Air Release Valve

Features

- Screwed BSP Parallel (ISO 228/1)
- Fitted with O-Ring seal

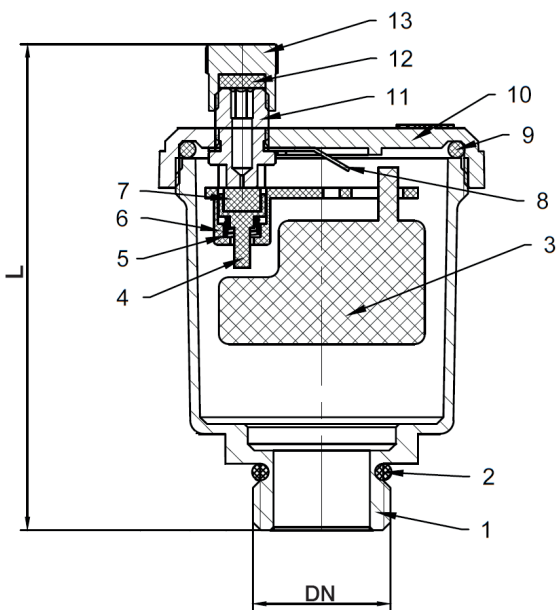

Pressure / Temperature

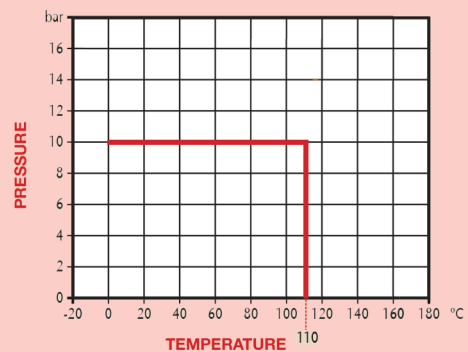

DN	1/2"	3/4"	1"
L	75.1	75.1	79.0
Kgs	0.19	0.20	0.24

N.	Part Name	Materials
1	Body	Brass CW617N
2	O-Ring	EPDM
3	Float	Polypropylene
4	Spring Seat	POM
5	Spring	AISI 304
6	Lever	POM
7	Rubber Gasket	EPDM
8	Lever Frame	Steel Zinc Plated
9	O-Ring	EPDM
10	Bonnet	Brass CW617N
11	Stem	Brass CW617N
12	Rubber Gasket	EPDM
13	Nut	Brass CW617N

Technical Data

Max Pressure	10 Bar
Max Temperature	0°C to +110°C

Dimensions in mm

This data sheet is designed as a guide and should not be regarded as wholly accurate in every detail. We reserve the right to amend the specification of any product without notice.

Bibcock Tap with Hose Union

Features

- Screwed BSP Taper (BS21) or NPT (ANSI B1.20.1)

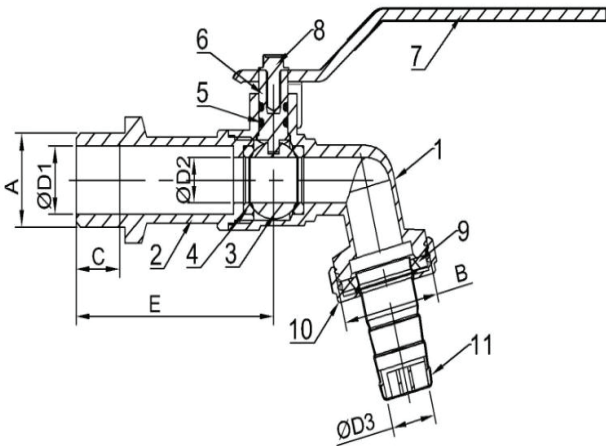

DN	1/2" x 3/4"	3/4" x 1"
A	G1/2"	G3/4"
B	G3/4"	G1"
C	12	12
ØD1	15	20
ØD2	10	12
ØD3	11.8	15.8
E	54.5	56.5
Kgs	0.19	0.25

N.	Part Name	Materials
1	Body	Brass CW617N Nickel Plated
2	Bonnet	Brass CW617N Nickel Plated
3	Ball	Brass CW617N Chrome Plated
4	Seat	PTFE
5	O-Ring	EPDM 70° SH
6	Stem	Brass Hpb59-3
7	Handle	Steel Q235
8	Screw	Steel Q235 Nickel Plated
9	Rubber Gasket	EPDM 70° SH
10	Cap	Brass CW617N Nickel Plated
11	Outlet	Stainless Steel 304 Nickel Plated

Technical Data

Max Pressure 16 Bar
 Max Temperature 0°C to +110°C

Dimensions in mm

This data sheet is designed as a guide and should not be regarded as wholly accurate in every detail. We reserve the right to amend the specification of any product without notice.

ART 1100 with Copper Ball



ART 1100 with Plastic Ball

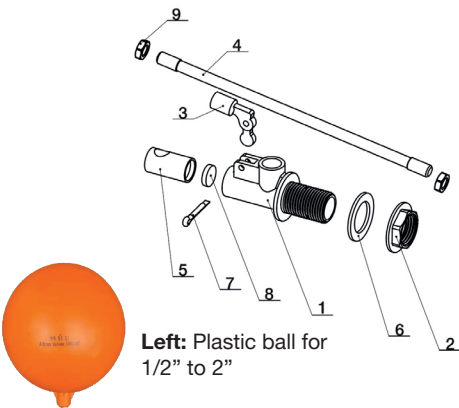
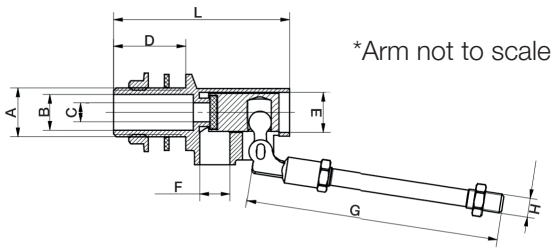

Left: Plastic ball for 1/2" to 2"

Plastic floats - Polyethylene

Diameter Size	4 1/2"	5"	8"	10"
Kgs	0.07	0.09	0.35	0.65



Left: Copper ball for 1/2" to 1"
Right: Copper ball for 1.1/4" to 2"



Copper floats

Diameter Size	4 1/2"	5"	8"	10"
Kgs	0.08	0.13	0.4	0.65

Technical Data

Max Pressure	16 Bar
Working Temperature	-20°C to +90°C

Float Valve

Features

- Screwed BSP Parallel (ISO 228/1)
- Supplied with locknut
- Machined fixed flange on valve body
- No jam single lever action
- Replaceable seals
- Copper and plastic float option available
- DZR Brass option also available

Pressure / Temperature

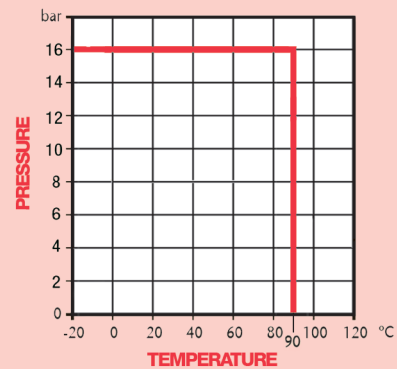

A	1/2"	3/4"	1"	1 1/4"	1 1/2"	2"
B	15	21	26.5	34.5	40	49.5
C	8	10	10	15	17	17
D	30	30	36	50	50	50
E	16.7	20.7	20.5	21.5	21.5	21.5
F	12.5	15	15	24	27	27
G	220	240	270	330	380	430
H	M8	M8	M8	M10	M10	M12
L	73	75	84	126	131	131
Float Size	4 1/2"	4 1/2"	5"	8"	8"	10"
Kgs (excl ball)	0.24	0.31	0.41	0.81	1.05	1.45

Size	Pressure	Flow	Pressure	Flow
1/2"	50psi	20 gpm	100psi	31 gpm
3/4"	50psi	40 gpm	100psi	60 gpm
1"	50psi	100 gpm	100psi	150 gpm
1.1/4" - 2"	50psi	250 gpm	100psi	348 gpm

N.	Part Name	Materials
1	Body	Brass HPb57-3
2	Back Nut	Brass HPb57-3
3	Plunger	Brass HPb57-3
4	Arm	Brass HPb57-3
5	Piston	Brass HPb57-3
6	Washer	EPDM
7	Pin	Brass HPb57-3
8	Washer	EPDM
9	Locking Nut	Stainless Steel 304

Dimensions in mm

This data sheet is designed as a guide and should not be regarded as wholly accurate in every detail. We reserve the right to amend the specification of any product without notice.

AVION

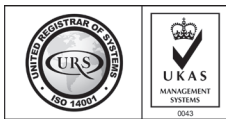

URS is a member of Registrar of Standards (Holdings) Ltd.
Certificate No. 1437B

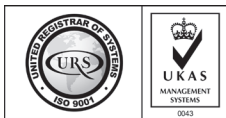

URS is a member of Registrar of Standards (Holdings) Ltd.
Certificate No. 1437A

Distributor