

ART 181

PN16 Ductile Iron Single Basket Strainer



Features

- Flanged only
- Flange conforms to BS EN1092 PN16
- Fusion Bonded Epoxy Coat Finish

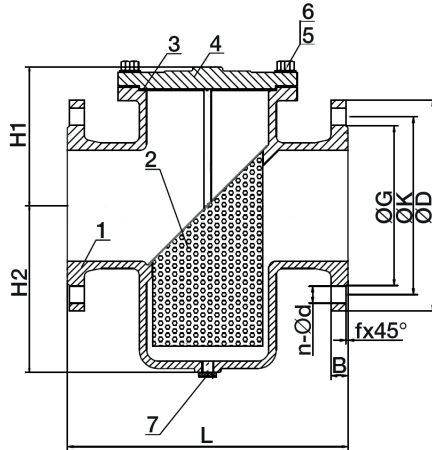

Technical data

Max pressure: 16 Bar

Working temp: 0°C to +80°C

DN	40	50	65	80	100	125	150	200	250	300	350	400	450	500	600
L	207	207	210	251	292	334	378	475	511	667	769	842	890	900	1000
D	150	165	185	200	220	250	285	340	405	460	520	580	640	715	840
K	110	125	145	160	180	210	240	295	355	410	470	525	585	650	770
G	88	100	119	135	156	186	212	268	318	373	433	483	546	605	710
B	19	19	19	19	19	19	19	20	22	24.5	26.5	28	30	31.5	36
f	3	3	3	3	3	3	3	3	3	3	4	4	4	4	5
n-Ød	4-19	4-19	4-19	8-19	8-19	8-19	8-23	12-23	12-28	12-28	16-28	16-31	20-31	20-34	20-37
H1	114	114	129	142	165	173	165	215	325	283	345	390	402	441	523
H2	98	98	112	125	160	185	235	295	340	423	585	590	628	696	834

N.	Part Name	Materials
1	Body	Ductile Iron GGG50
2	Screen	Stainless Steel 304
3	Cover Gasket	EPDM
4	Cover	Ductile Iron GGG50
5	Bolt	Stainless Steel A2-70
6	Bolt Nut	Stainless Steel A2-70
7	Plug	Stainless Steel 304

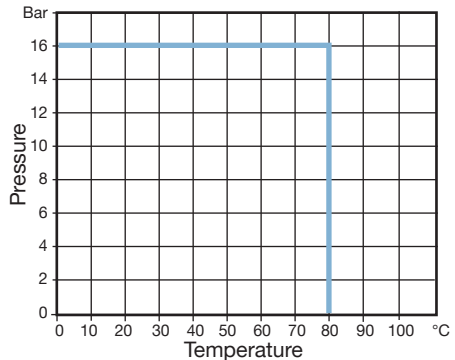

V1. Dimensions in mm

This data sheet is designed as a guide and should not be regarded as wholly accurate in every detail. We reserve the right to amend the specification of any product without notice.