

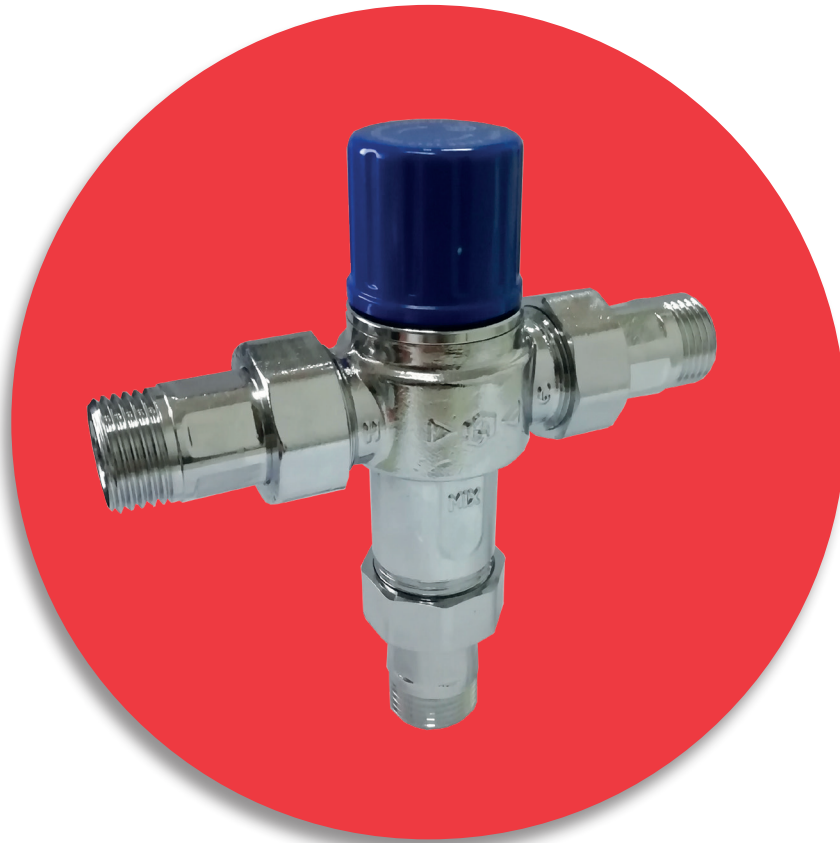

TMV3 Installation & Operating Manual



ART 33 Screwed Thermostatic Mixing Valve

Albion Valves (UK) Ltd
www.albionvalvesuk.com
Email: sales@albionvalvesuk.com
Tel: 01226 729900



Contents

1. Introduction
2. Approvals
3. Technical Specification
4. Product Dimensions
5. Conditions of normal use (TMV3)
6. Installation and Assembly
7. Commissioning & Adjustment
8. Maintenance & In-Service Testing
9. TMV Cleaning Instructions
10. Warranty

1. Introduction

- The valves covered by these instructions have been tested and certified as being in compliance with BS 7942:2000 and NHS Estates Model Engineering Specification DH HTM 04-01 Specification D 08.
- Valves operating outside the requirements of these standards are not covered by the TMV3 Scheme and are not guaranteed to operate as type 3 valves.
- The National Health Service Estates (NHSE) Health Guidance Note (HGN) makes reference to three types of valve:
 - Type 1
 - o Having both flow control and user adjustment of mixed water temperature
 - Type 2
 - o Having flow control and pre-set mixed water temperature
 - Type 3
 - o Without flow control and with pre-set temperature
- The installer should be aware of his duty of care and responsibility in ensuring that compliance with regulation is adhered to. The valve is not guaranteed to function correctly to the TMV3 specification unless it is installed and used in accordance with these instructions.
- The Albion ART 33 thermostatic mixing valve is available in sizes 1/2" & 3/4", it is intended to be fitted into applications where the reliable control of hot water temperature is necessary to prevent scalding.
- In the event of cold-water supply failure, the product will shut off the hot water supply.



2. Approvals

- The Albion ART 33 is certified under the TMV3 scheme and has been independently tested by the recognized test laboratory NSF Wales and is a Water Regulations Advisory Scheme (WRAS) approved product and the listed in the Water Fittings and Material Directory.

3. Technical Specification

Factory Temperature Setting	42°C
Temperature Adjustment Range	30°C – 48°C
Mix Temperature Stability	+/-2°C
Cold Water Supply Temperature	5°C – 25°C
Hot Water Supply Temperature	55°C – 65°C
Temperature Differential (Hot Inlet – Outlet)	12°C
Supply Pressure Imbalance	2:1
Maximum Static Pressure	10 Bar

4. Product Dimensions

Dimensions are given for ART 33 in Table 1

Table 1

Model	DN Size	B	C	D	E
ART 33	1/2"	59	114	126	50.9
ART 33	3/4"	61	135	137	50.9

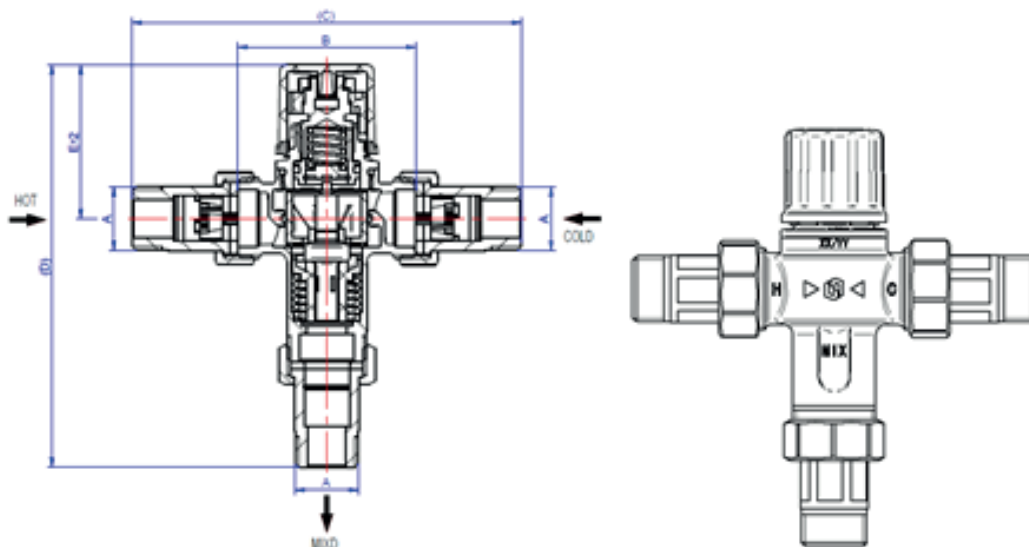



5. Conditions of Normal Use (TMV3)

Water Regulations

- The thermostatic mixing valve must be installed in accordance with the regulations of the local water company and the Water Supply (Water Fittings) Regulations 1999.

Operating Pressure Range	High Pressure	Low Pressure
Maximum Static Pressure (Bar)	10	10
Hot & Cold Pressure (Bar)	1.0 – 5.0	0.2 – 1.0
Hot Supply Temperature (°C)	55 – 65	55 – 65
Cold Supply Temperature (°C)	5 – 20	5 – 20
Mix Water Temperature (°C)	Maximum 46	Maximum 46
Temperature Differential (°C)	12	12

- Thermostatic Mixing Valves are temperature sensitive devices and must not be subjected to extreme temperatures, either hot or cold, in use for installation.
- Valves operating outside these conditions of use cannot be guaranteed to operate as TMV 3 valves.

Designations of Use

HP - B / S / W / T44
LP - B / S / W

6. Installation & Assembly

Installation diagram

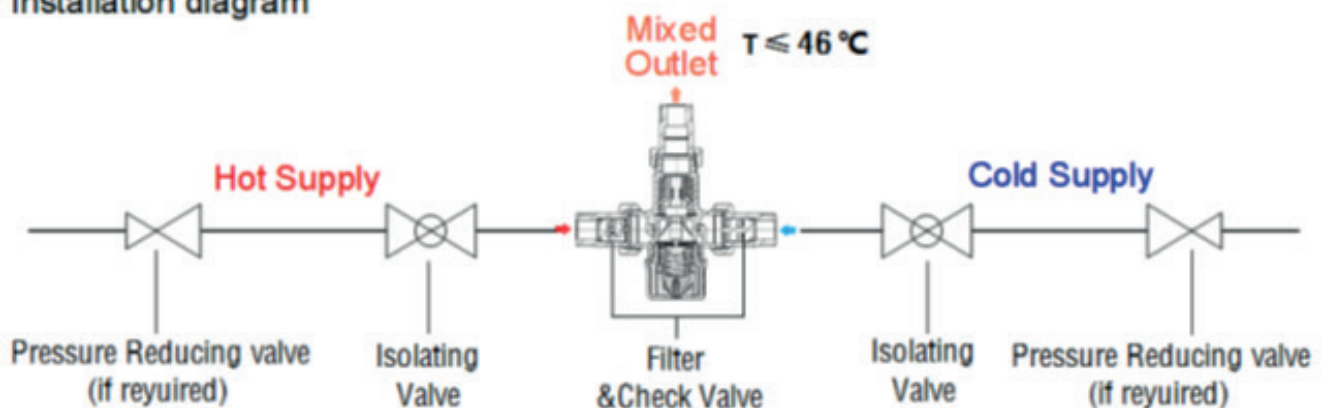



Assembly Procedure

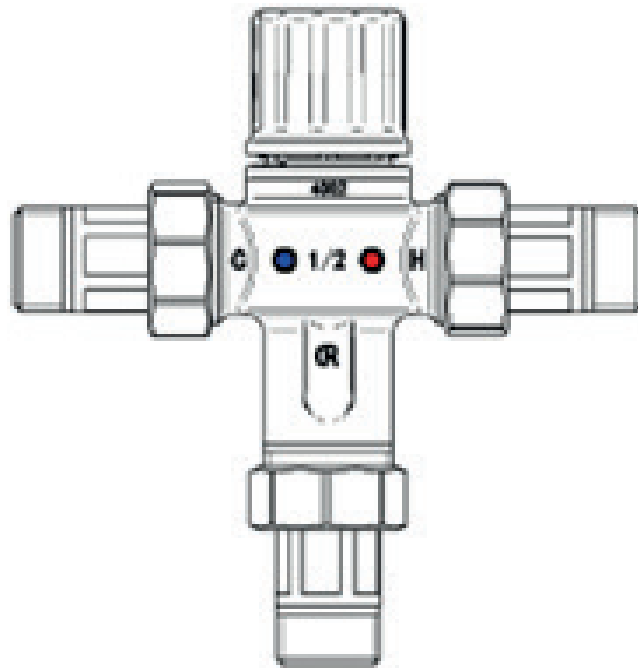

- The valve body is clearly marked with “C” and a blue indicator for cold and “H” and a red indicator for hot.
- The use of sealing compounds is not recommended.
- Before installation, the hot and cold-water inlet of the mixing valve must be clear of debris. the valve must be correctly connected to the respective supplies.
- Isolation valves must be fitted adjacent to the valve inlet. A Pressure reducing valve (PRV) must be fitted if deemed necessary.
- Check the main valve assembly bores are free of debris and the end sealing faces are clean.
- Check the two tailpieces and confirm they are complete with union nuts and compression nuts with olives.
- Insert the sealing washer into the inlets and outlet and screw the inlet and outlet fittings onto the valve body, taking care not to over tighten.
- Remove the compression nuts and olives from the tailpieces. Locate the inlet filter screens and insert them into the bore of the tailpieces up to the shoulder.
- Assemble the valve to the pipe work and ensure the hot and cold-water pipes have full penetration into the tailpieces. The compression fittings supplied allow for direct connection to BS 22mm OD tube or BS 15mm OD tube.



- Tighten the compression nuts ensuring that the end of the pipe remains in contact with the filter element.
- After installation check carefully for leaks.
- The valve must always be fitted in a location where it is accessible for both test and maintenance.

Exploded View of ART 33

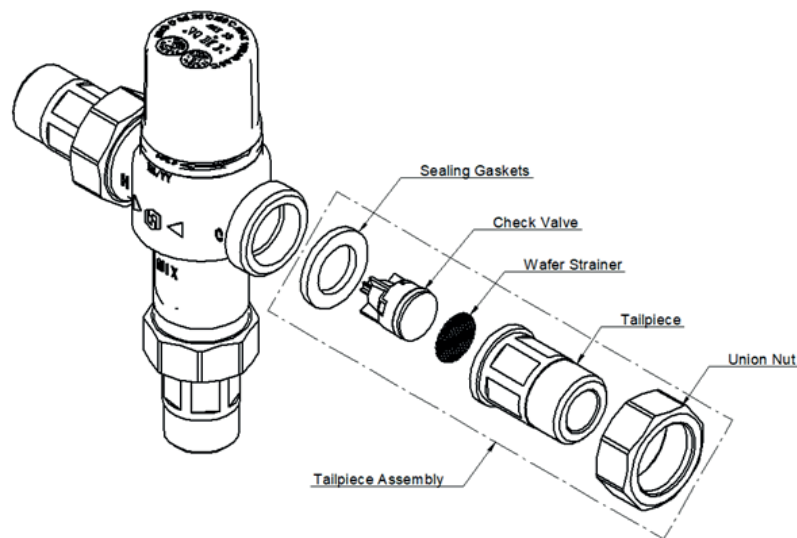

7. Commissioning & Adjustment

- The Albion ART 33 thermostatic mixing valve is supplied factory pre-set at 41--43°C. However, installation conditions will dictate, that the product be adjusted on site.
- Prior to commencing commissioning, the following checks should be carried out
 - The designation of the TMV matches the application.
 - The supply pressures and temperatures are within the operating range of the valve.
 - Isolating valves are fitted.
 - The supply temperatures are within the range permitted for the valve and by guidance information on the prevention of legionella etc.
- If all these conditions are met, proceed to set the temperature as below: -
 - Remove the protective cap on top of the valve.
 - Back-out the nut using a hexagon wrench:
 - o To increase the temperature, turn clockwise
 - o To decrease the temperature, turn anti-clockwise



- Temperature is in accordance with the valve application as per the table below: -

HP (1.0 – 5.0 Bar) High Pressure	LP (0.2 – 1 Bar) Low Pressure	Application	Maximum Temperature (°C)
HP-B	LP-B	Bidet	38
HP-S	LP-S	Shower	41
HP-W	LP-W	Wash Basin	41
HP-T44		Bath	44

- When the valve has been installed with the correct conditions of use it is advised that the valve is subjected to normal operation prior to the commissioning at the application temperature. Operate the valve from full cold to full hot at least three times by removing the blue plastic cap and using a hexagon wrench to adjust.
- With the valve at the full cold position bring the valve to the correct application temperature by turning the nut clockwise. If the valve exceeds this temperature, return the valve to the full cold condition, and reset it to the correct temperature +0-2°C. Do not set a valve with a lowered temperature as this will not provide consistent operation.
- After adjustment replace the cap to lock the valve in position and prevent tampering.
- Commissioning Test sequence
 - After adjusting the temperature of the mixed water in accordance with the valve application.
- Record the temperature of the hot and cold-water supplies.
- Record the temperature of the mixed water at the largest draw-off flow rate.
- Record the temperature of the mixed water at a smaller draw-off flow rate, which shall be measured.
- Isolate the cold-water supply to the mixing valve and monitor the mixed water temperature recording the maximum temperature achieved and the final stabilized temperature.
- Record the equipment, thermometer etc. used for the measurements.
- The final stabilised temperature must not exceed the values in the table below and must never exceed 46°C: -

Application	Max Temperature °C
Bidet	40
Shower	43
Wash Basin	43
Bath	46 (note 1)



Note 1

- 46°C is the maximum mixed water temperature from the bath tap. The maximum temperature takes account of the allowable temperature tolerances inherent in thermostatic mixing valves and temperature losses in metal baths. It is not a safe bathing temperature for adults or children.
- The British Burns Association recommends 37 to 37.5°C as a comfortable bathing temperature for children. In premises covered by the Care Standards Act 2000, the maximum mixed water outlet temperature is 43°C.

8. Maintenance & In-Service Testing

- The purpose of in-service testing is to regularly monitor and record the performance of the thermostatic mixing valve. Deterioration in performance can indicate the need for service work on the valve and/or water supply.
- Carry out the test sequence using the same or equivalent equipment used for commissioning the valve.
- If the mixed water temperature has changed significantly from the previous test results (e.g. >1°C), record the change and before re-adjusting the mixed water temperature carry out the following checks;
 - All in-line or integral filters are clean.
 - Any in-line or integral non-return valves or other anti-back siphonage devices are in good working condition.
 - Any isolation valves are fully open.
- With an acceptable mixed water temperature, complete the test sequence as per section 7 of this document.
- In the absence of any other instruction or guidance, it is recommended that In-Service Tests are carried out as per the table below. If the temperature is outside of the expected range it will be necessary to remove and clean the valve in accordance with the instructions in the table below: -

Temperature Variation (°C)	Comment	Service Frequency (Weeks)
+/- 1°C	N/A	24 – 28 Weeks
+/- 1°C – 2°C	In either one period	24 – 28 Weeks
+/- 1°C – 2°C	In both periods	18 – 21 Weeks
+/- Exceed 2°C	In either period	18 – 21 Weeks

- If there is a residual flow during the commissioning or bi-annual verification (cold water supply isolation test) then this is acceptable providing the temperature of the water seeping from the valve is no more than 2°C above the designated maximum mixed water



outlet temperature setting of the valve.

- If a water supply is fed by gravity then the supply pressure should be verified to ensure the conditions of use are appropriate for the valve.
- The fitting of isolation valves is required as close as is practicable to the water supply inlets of the thermostatic mixing valve.
- Temperature readings should be taken at the normal flow rate after allowing the system to stabilize. The sensing part of the thermometer probe must be fully submerged in the water that is to be tested. Any TMV that has been adjusted or serviced must be re-commissioned and re-tested in accordance with the manufacturer's instructions.
- In the absence of any other instruction or guidance, it is recommended that In-service Tests are carried out once every 6 months as a minimum.

9. TMV Cleaning Instructions

- Most domestic water supplies contain calcium which will separate out when the water is heated in a system. The degree and speed of scaling may vary depending on factors such as water flow rates, system design, the hardness of the water and the temperature to which the water is heated.
- Deposits of scale may over time form in the valve, particularly at the hot inlet. The formation of the scale may adversely affect the performance of the valve which will be detected during the in-service testing. If this occurs it will be necessary to remove the valve for de-scaling and service.

Cleaning Procedure

- Isolate the hot and cold supply.
- Remove the valve to a clean working area.
- Remove the protective cap.
- Unscrew the headwork of the valve.
- Carefully remove the temperature sensitive thermal element and piston assembly and put to one side.
- Remove the main spring and flow guide and carefully put to one side.
- Inspect the components for contamination or damage.



- Clean or replace as necessary.
- There may be a need to periodically grease components. Please ensure that the grease is WRAS approved.
- Remove the O-ring.
- Clean the valve body and headwork using a propriety de-scaler.
- Thoroughly rinse the body and headwork in clean water.
- Carefully fit O-ring to body.
- Carefully re-fit all components and perform the commissioning sequence.

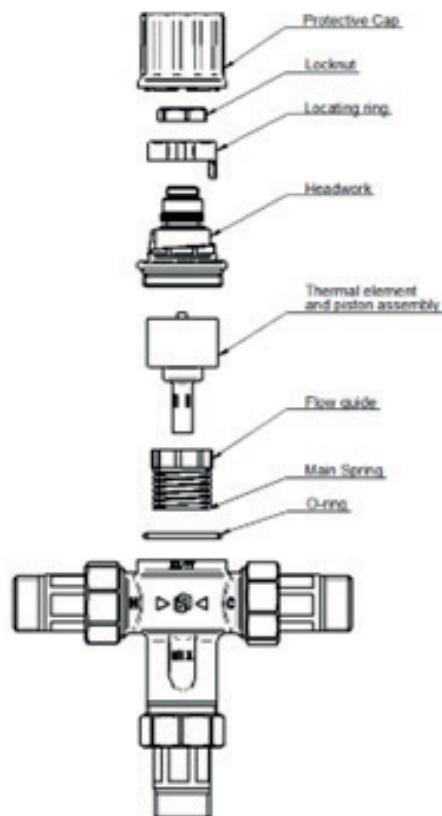



10. Warranty

- Albion Valves (UK) Ltd offer a 12 month guarantee of the ART 33 TMV.
- The guarantee offered covers manufacturing / material defects.
- The guarantee will be void should the product not have been fitted and maintained as per Albion Valves (UK) Ltd instruction.
- Accidental damage is not covered by the guarantee.



About Albion Valves (UK) Ltd

Albion has been supplying valves and fittings to the building services and industrial markets for the past 40 years.

Albion was created with the sole purpose of providing quality products at an affordable price. With a growing reputation for quality and reliability, Albion is now an established brand providing the industry with a trusted alternative to premium-priced products.

Our commitment to setting the highest standards in all areas of our business means, if you're looking for quality, service, delivery and choice — you'll find it's all at Albion.

Quality

Whatever you need, you can rest assured that if it comes from Albion it has been designed and manufactured to deliver optimum performance and is accredited with the necessary approvals. Our in-house quality department are always on hand too!

Service

We pride ourselves on our customer service – we have even won awards for it! Our cradle to grave approach means you will never be on your own!

Delivery

We know that time is money, and when a priority project depends on a part you can trust Albion to deliver – next day for all orders placed before 4:00PM.

Choice

We may have started out with a single brass ball valve, but our range has grown substantially since and we now consider ourselves to be a 'One Stop Shop' with our comprehensive range. It is becoming more and more apparent to the industry, that it really is all at Albion.