

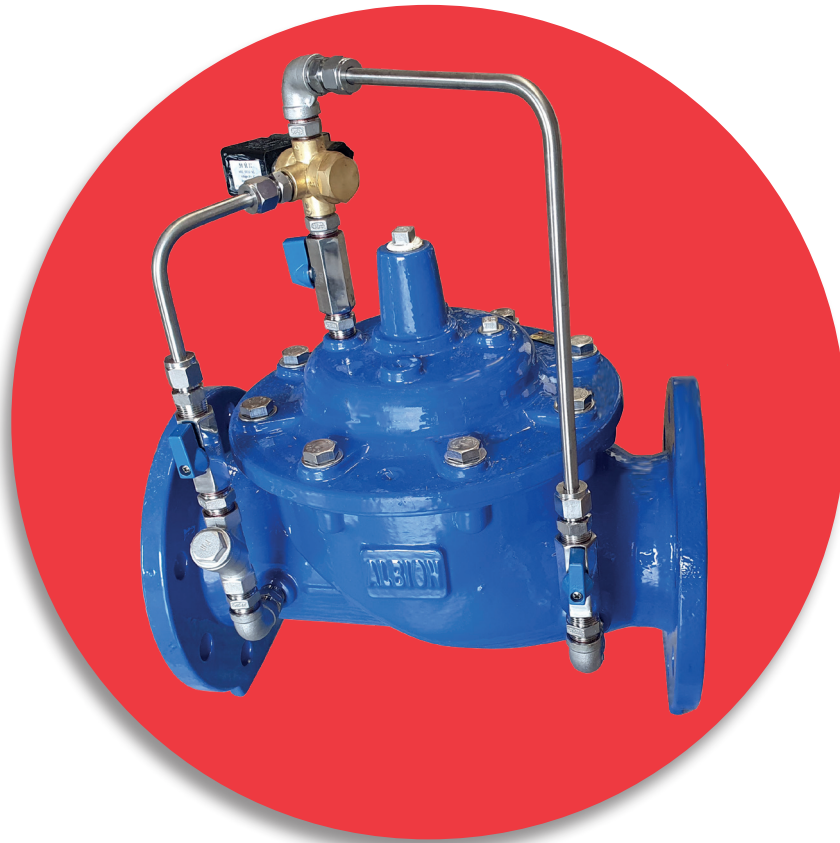

Installation & Operating Manual



ART 6600 Solenoid ON / OFF Control Valve

Albion Valves (UK) Ltd
www.albionvalvesuk.com
Email: sales@albionvalvesuk.com
Tel: 01226 729900



ART 6600 Function

Solenoid Control Valve

Albion Valves (UK) Ltd ART 6600 Solenoid Automatic Control Valve is used open and close as per the requirement and the feed which is given to the Solenoid Pilot. The valves can be normally closed or normally open as per the customer requirement.

Ball Valve

The main function is to shut off the water between the pipe system and pilot control pipe system.

Pilot Solenoid Valve

The main function of the Pilot Solenoid valve is to open and close as per the requirement which inturn open and closes the main valve.

ART 6600 Installation

- Installation of Albion ART 6600 should only be undertaken by competent professionals;
- Confirm that the product size and pressure meet the design requirement before installation commences;
- Ensure that the flow direction matches the flow direction arrow on the valve;
- Ensure that the pipework system has been flushed to remove any debris prior to installation;
- Ensure that the valve is installed on a horizontal plane for sizes DN 150 and above. Sizes up to and including DN 100 can be installed either horizontally or vertically;
- Ensure that sufficient space is available both upstream and downstream of the valve to allow suitable maintenance;
- Ensure the ball valve is in an open position prior to commissioning the valve;
- If there is chance for the water to be turbulent the float must be adequately protected.
- Always before ordering the Solenoid automatic control valves it should be made sure if the requirement is normally closed or normally opened.

ART 6600 Start-Up Procedure

Close upstream and downstream valves to isolate the valve from line pressure. Open all Isolation Ball Valves on the pilot piping system, if so equipped. If the supplied valve is normally closed Solenoid Automatic Control Valve then the Solenoid pilot will also be in the closed condition which will make the main valve also to close. Please make sure the supply voltage matches the solenoid pilot valve voltage;

Slowly open the upstream isolation valve to allow controlled filling of the valve. Vent air by loosening control tubing or pipe plug at the highest point possible. Carefully loosen enough cover screws on control pilot(s) to vent entrapped air. Retighten when water vents.



Once the filling is complete then the valve will be in the closed position as the pilot valve is also in the closed position. When the feed is given to the pilot to open then the main valve also opens and the flow is achieved downstream. Please make sure the downstream Isolation valve is also opened during this time.

ART 6600 Repair Instruction

Main valve always open

Failure Mode	Repair Method
Solenoid pilot valve not operating	Change the solenoid valve
Sealing position leakage	Tighten the nut or change the sealing parts
Main valve diaphragm broken	Change the diaphragm
Debris accumulated under the bottom of main valve	Disassemble, clean, check and change the damaged parts
Seat leakage	Replace seal
Joint leakage between the SS connection parts	Tighten the nut or change SS part

Main Valve will not close

Failure Mode	Repair Method
Solenoid pilot valve not operating	Change the solenoid valve
Ball valve closed	Open the ball valve

Solenoid valve Installation Layout:

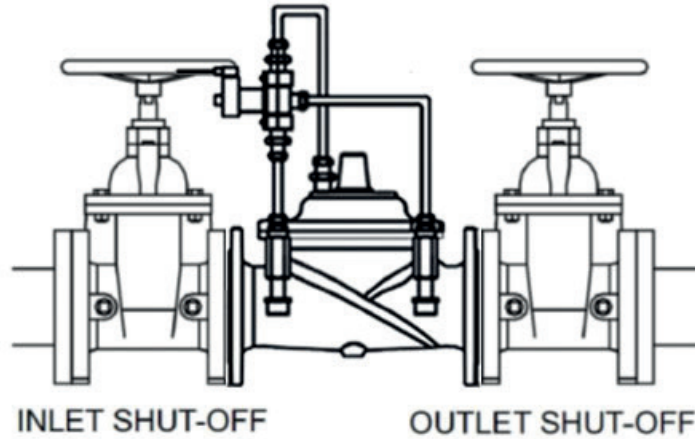

Main Valve Part List

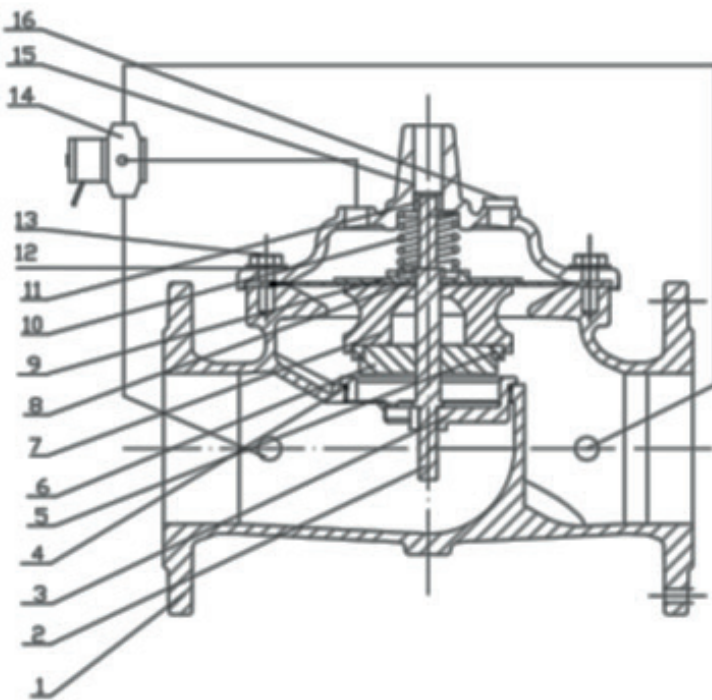

No.	Part Name	Material
1	Body	Ductile Iron
2	Stem	Stainless Steel 304
3	Seat	Stainless Steel 304
4	O-Ring	NBR
5	Disc Ring	NBR
6	Disc Retainer	Ductile Iron
7	Disc Guide	Ductile Iron
8	Diaphragm	EPDM
9	Diaphragm Washer	Ductile Iron
10	Spring	Stainless Steel 304
11	Cover Bearing	Stainless Steel 304
12	Screw	Stainless Steel 304
13	Washer	Stainless Steel 304
14	Solenoid Valve	Stainless Steel 304
15	Cover	Ductile Iron
16	Plug	Stainless Steel 304



About Albion Valves (UK) Ltd

Albion has been supplying valves and fittings to the building services and industrial markets for the past 40 years.

Albion was created with the sole purpose of providing quality products at an affordable price. With a growing reputation for quality and reliability, Albion is now an established brand providing the industry with a trusted alternative to premium-priced products.

Our commitment to setting the highest standards in all areas of our business means, if you're looking for quality, service, delivery and choice — you'll find it's all at Albion.

Quality

Whatever you need, you can rest assured that if it comes from Albion it has been designed and manufactured to deliver optimum performance and is accredited with the necessary approvals. Our in-house quality department are always on hand too!

Service

We pride ourselves on our customer service – we have even won awards for it! Our cradle to grave approach means you will never be on your own!

Delivery

We know that time is money, and when a priority project depends on a part you can trust Albion to deliver – next day for all orders placed before 4:00PM.

Choice

We may have started out with a single brass ball valve, but our range has grown substantially since and we now consider ourselves to be a 'One Stop Shop' with our comprehensive range. It is becoming more and more apparent to the industry, that it really is all at Albion.