

ART 902T

PN82 Stainless Steel

2 Piece Ball Valve



Features

- BSP Taper (ISO 7/1)
- Full bore
- PN82 rated
- Locking device
- Tee handles available for 1/4", 3/8" and 1/2"



Technical data

Max pressure: 1/4" - 1" 82 Bar
 1 1/4" - 1 1/2" 69 Bar
 2" - 3" 62 Bar

Working temp: -25°C to +200°C

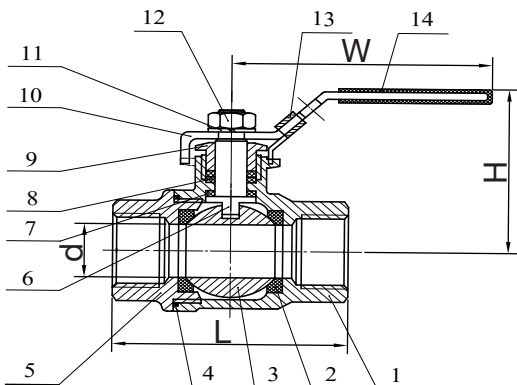

DN	1/4"	3/8"	1/2"	3/4"	1"	1 1/4"	1 1/2"	2"	2 1/2"	3"
d	11.5	12.5	15.0	20.0	25.0	32.0	40.0	50.0	65.0	76.0
L	49	49	57	64	77	90	105	125	153	172
H	54	54	56	65	70	75	93	99	123	140
W	105	105	105	118	150	150	182	182	254	254
Torque	4	4	5	8	10	14	18	25	48	75
Kv	6.0	16.0	35.0	46.0	72.0	105.0	170.0	275.0	502	905
Kgs	0.23	0.23	0.24	0.45	0.65	1.05	1.70	2.61	5.01	7.61

N. Part Name Materials

1	Body	CF8M
2	Ball Seat	R-PTFE (15%)
3	Ball	Stainless Steel 316
4	Body Gasket	PTFE
5	Cap	CF8M
6	Stem	Stainless Steel 316
7	Thrust Washer	PTFE
8	Stem Packing	PTFE
9	Gland Nut	Stainless Steel 304
10	Handle	Stainless Steel 304
11	Spring Washer	Stainless Steel 304
12	Nut	Stainless Steel 304
13	Lock Device	Stainless Steel 304
14	Handle Cover	Plastic

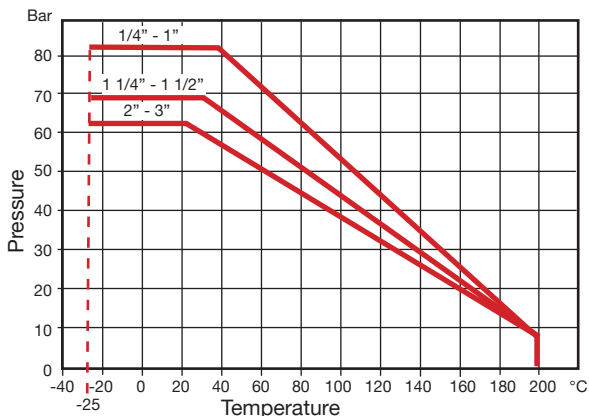

V2 Dimensions in mm

This data sheet is designed as a guide and should not be regarded as wholly accurate in every detail. We reserve the right to amend the specification of any product without notice.