

HQ3

HQ Electric Actuator for Albion ball and butterfly valves



Features

- Small, light and compact design
- Manual override lever
- 4 off limit switches
- Anti condensation heater
- Visual indication including LED lamps to show either open or closed
- 3m flying lead - no need for the cover to be removed during installation
- One unit covers 24VDC, 110VAC & 230VAC

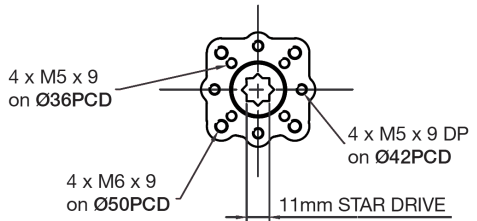
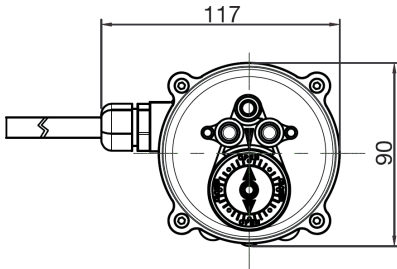

Standard Specification

Enclosure	: Aluminium weatherproof IP67
Power supply	: 85-265v 50/60Hz. 24v DC
Duty cycle (on/off duty)	: S4, 50%
Motor	: Reversible motor
Limit switches	: 2 x SPDT, 250V AC 3A
Additional limit switches	: 2 x SPDT, 250V AC 3A
Space heater	: 0.5W
Manual override	: Push button / lever operated
Movement angle	: 90° ± 5° (0° to 90°)
Ambient temperature	: -20°C to 70°C
External coating	: Dry powder, polyester

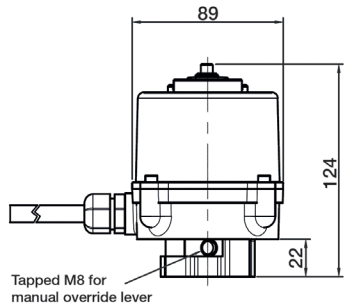

Performance

Model	Maximum Output Torque	Operating time 50/60Hz - 90°	Mounting base ISO 5211
HQ3	30NM	12 Secs	F03/F04/F05 11mm Star

Model	Rated Current (A)			Weight
	AC 1PH. 50/60Hz		DC	
	110V	220V	24V	
HQ3	0.1/0.1	0.1/0.1	0.5	1.2kg

