

ART 642

Gunmetal Safety Valve



Features

- Screwed BSP Parallel (ISO 228/1)
- Suitable for gases and liquids
- Fitted with diaphragm to protect spring housing
- Set range 0.5 to 16 Bar
- ISO 4126-1, PED 2014/68/EU
- Marine approvals - GL, DNV
- ATEX approval available at extra cost
- 5 year warranty
- Test certificate to EN10204-3.1 available on request



Technical data

Max pressure: 16 Bar

Working temp: EPDM Diaphragm
-50°C to 195°C

See overleaf for discharge capacity.

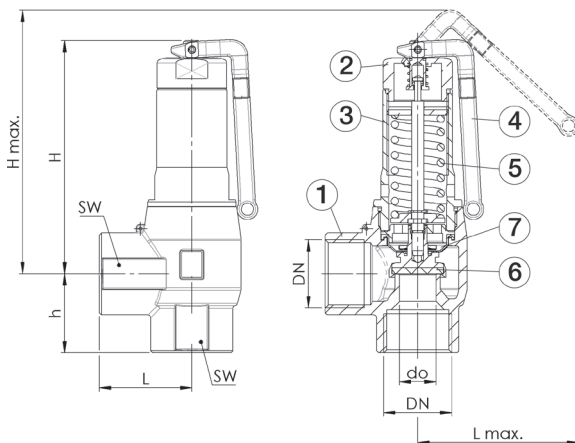

DN	1/2"	3/4"	1"	1 1/4"	1 1/2"	2"	2 1/2"
L	35	42	45	47	58	68	80
Lmax	63	75	78	100	140	150	155
H	90	106	120	150	192	229	275
Hmax	102	120	133	153	210	252	298
h	28	36	38	37	45	55	65
SW	27	34	41	50	60	70	90
do	13	15	18	23	30	39	48
Kgs	0.5	0.8	1.1	1.7	3.3	5.8	8.9

N.	Part Name	Materials
1	Body	Gunmetal
2	Housing Cap	Brass CC499K / Gunmetal
3	Spring Housing	Brass CC499K / Gunmetal
4	Lifting Lever	Stainless Steel CF8M
5	Spring	Stainless Steel 302
6	Seat - Seal	PTFE
7	Diaphragm	EPDM

Typical Applications

- Pressure vessels
- Mechanical engineering
- Pump protection
- Pressure booster systems water / air-side
- Cooling / chilling systems
- Steam and industrial boiler systems

ART 642

Nm³/h - Air
Kg/h - Steam
M³/h - Water
Kw - Heating Water



Discharge Capacities

Blowing off rates at 10% above set pressure

DN	1/2"				3/4"				1"				1 1/4"			
Bar	Nm ³ /h	kg/h	m ³ /h	kW	Nm ³ /h	kg/h	m ³ /h	kW	Nm ³ /h	kg/h	m ³ /h	kW	Nm ³ /h	kg/h	m ³ /h	kW
0.5	76	62	2.3	38	101	83	3.1	51	143	117	4.3	72	234	191	7.0	118
1	110	88	3.2	54	147	117	4.2	71	207	165	5.8	101	338	269	9.5	164
2	180	142	4.5	85	240	189	6.0	113	340	268	8.2	160	556	437	13.5	262
3	248	193	5.5	114	330	257	7.3	152	468	365	10.1	215	764	595	16.5	352
4	312	242	6.4	141	416	322	8.5	188	592	458	11.7	267	966	748	19.1	436
5	376	290	7.1	167	501	386	9.5	223	712	549	13.1	316	1163	896	21.3	517
6	440	337	7.8	193	586	449	10.4	256	833	639	14.3	365	1359	1043	23.4	595
7	503	385	8.4	218	670	513	11.2	290	953	729	15.5	412	1556	1190	25.2	673
8	567	432	9.0	242	755	576	12.0	323	1074	819	16.5	459	1753	1337	27.0	749
9	631	480	9.6	267	840	639	12.7	355	1194	908	17.5	505	1950	1483	28.6	825
10	694	527	10.1	291	925	702	13.4	387	1315	998	18.5	550	2147	1629	30.2	899
11	758	574	10.6	315	1009	765	14.1	419	1435	1088	19.4	595	2343	1776	31.7	972
12	822	622	11.1	338	1094	828	14.7	450	1556	1177	20.2	640	2540	1922	33.1	1045
13	885	669	11.5	361	1179	891	15.3	481	1676	1266	21.1	684	2737	2068	34.4	1116
14	949	716	11.9	384	1264	954	15.9	511	1797	1356	21.9	727	2934	2214	35.7	1187
15	1013	764	12.4	407	1348	1017	16.5	542	1917	1446	22.6	770	3130	2361	37.0	1257
16	1076	811	12.8	429	1433	1080	17.0	571	2038	1535	23.4	813	3327	2507	38.2	1327

DN	1 1/2"				2"				2 1/2"			
Bar	Nm ³ /h	kg/h	m ³ /h	kW	Nm ³ /h	kg/h	m ³ /h	kW	Nm ³ /h	kg/h	m ³ /h	kW
0.5	338	276	10.5	170	571	466	17.7	288	864	706	26.8	436
1	491	392	14.3	239	831	662	24.1	404	1258	1003	36.5	612
2	816	642	20.2	385	1379	1085	34.2	650	2089	1643	51.8	985
3	1128	879	24.8	520	1907	1486	41.9	878	2888	2251	63.5	1330
4	1430	1107	28.7	646	2417	1872	48.4	1092	3661	2835	73.4	1654
5	1721	1326	32.1	765	2909	2241	54.2	1293	4407	3395	82.1	1958
6	2013	1544	35.1	882	3402	2609	59.4	1490	5153	3953	89.9	2257
7	2304	1762	37.9	996	3894	2977	64.1	1684	5899	4510	97.1	2551
8	2595	1979	40.6	1109	4386	3344	68.6	1875	6644	5066	103.9	2840
9	2887	2196	43.0	1221	4879	3711	72.7	2063	7390	5621	110.2	3125
10	3178	2412	45.4	1331	5371	4077	76.7	2249	8136	6175	116.1	3407
11	3469	2629	47.6	1439	5863	4443	80.4	2433	8882	6730	121.8	3685
12	3761	2845	49.7	1547	6356	4809	84.0	2614	9627	7284	127.2	3959
13	4052	3061	51.7	1652	6848	5174	87.4	2793	10373	7837	132.4	4230
14	4343	3278	53.7	1758	7340	5541	90.7	2970	11119	8393	137.4	4500
15	4635	3495	55.6	1862	7833	5907	93.9	3146	11865	8948	142.3	4766
16	4926	3711	57.4	1964	8325	6272	97.0	3319	12611	9501	146.9	5028

Seat-Seal/Diaphragm Options

Option	Materials	Type	Working Temp.
PTFE/EPDM	Polytetrafluorethylen/Ethylen-Propylene-Diene (Standard)	Flat seal and moulded diaphragm	-50°C to +195°C
EPDM/EPDM	Ethylen-Propylene-Diene/Ethylen-Propylene-Diene	Flat seal and moulded diaphragm	-50°C to +150°C
PTFE/FKM	Polytetrafluorethylen/Fluorcarbon	Flat seal and moulded diaphragm	-30°C to +200°C
FKM/FKM	Fluorcarbon/Fluorcarbon	Elastomere seals and moulded diaphragm	-20°C to +200°C