

# ART 55 PRS

## DZR Brass Press Ball Valve

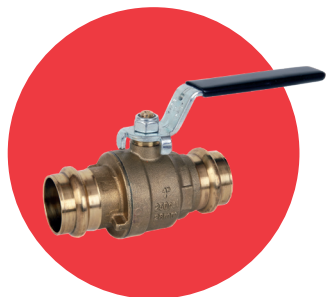

### Features

- Universal M & V Press 15mm to 35mm
- Dedicated M & V Profiles 42mm & 54mm (See diagram)
- Full Bore
- Thermal extension available
- Non-press leak detection system
- 5 year warranty
- Suitable for cold pressure connection to stainless steel, copper and carbon steel pipes



### Technical data

Max pressure:	DN15	24 Bar
	DN22 & DN28	20 Bar
	DN35 - DN54	17 Bar
Working temp:	-20°C to 140°C	

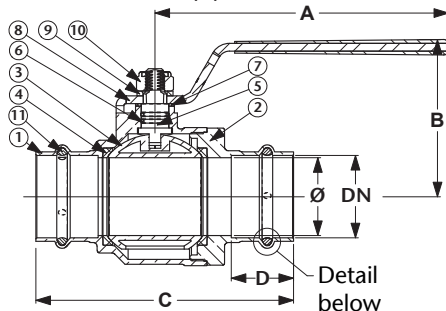

DN	15	22	28	35	42	54
A	90	90	110	110	150	150
B	47	52	57	66	81	88
C (M press)	78	91	99	107	133	155
C (V press)	78	91	99	107	133	163
D (M Press)	22	25	27	27	32	33
D (V Press)	22	25	27	27	32	37
Kv	17	41	68	123	198	290
Kgs	0.19	0.31	0.49	0.72	1.17	1.66(M) 1.75 (V)

'M' Press (DN42)

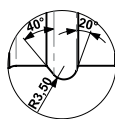

'M' Press (DN54)

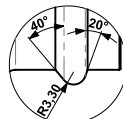

'V' Press (DN42+54)

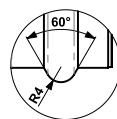

NB: Sizes 15mm to 35mm can be pressed with both 'M' and 'V' press jaws. Always use the appropriate 'M' or 'V' press sling to press sizes 42mm and 54mm.

N.	Part Name	Materials
1	Body	DZR Brass CW511L-DW
2	Press End	DZR Brass CW511L-DW
3	Ball	Brass Chrome Plated
4	Ball Gaskets	PTFE
5	Stem	Brass
6	O-Ring	FKM 70 SH
7	Anti-Friction Ring	PTFE
8	Handle	Steel
9	Washer	Brass
10	Self-Locking Nut	Steel
11	O-Ring	EPDM 70 PEROX

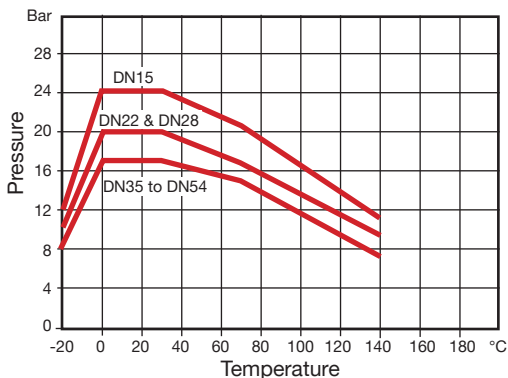

V2. Dimensions in mm

This data sheet is designed as a guide and should not be regarded as wholly accurate in every detail. We reserve the right to amend the specification of any product without notice.