

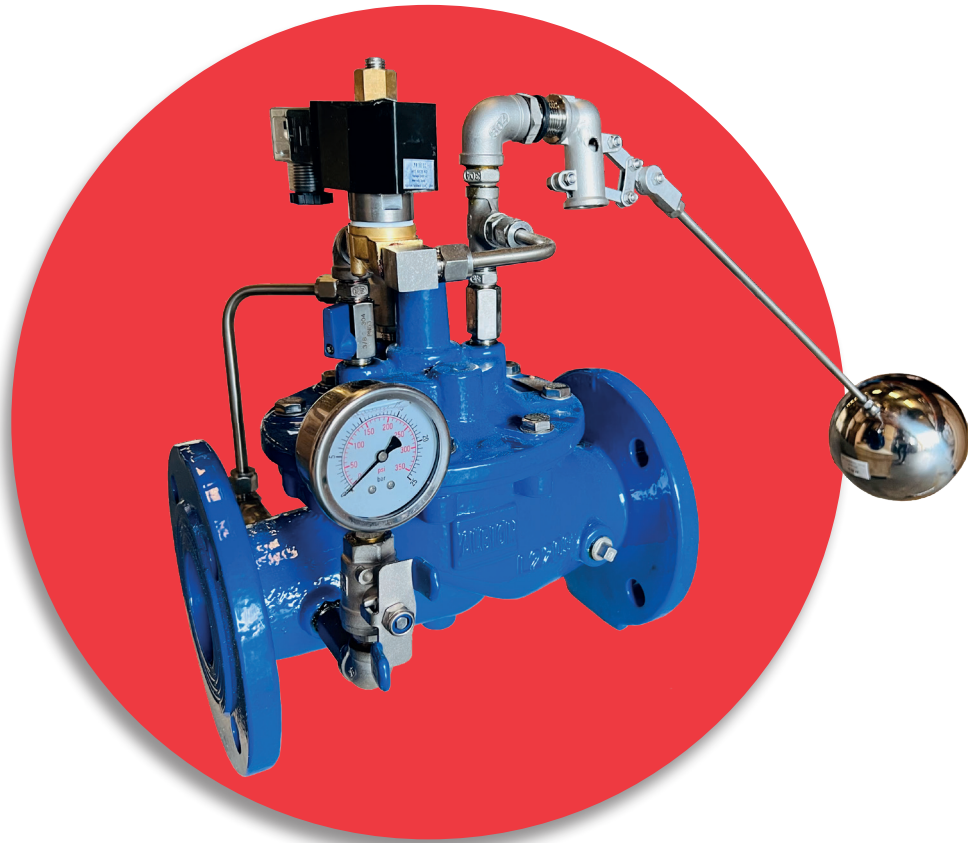

Installation & Operating Manual



ART 6100 Modulating with Solenoid Float Control Valve

Albion Valves (UK) Ltd
www.albionvalvesuk.com
Email: sales@albionvalvesuk.com
Tel: 01226 729900



ART 6100 Function

- Ball Valve
 - o The main function is to shut off the water between pipe system and pilot control pipe system.

- Needle Valve
 - o The main function is to adjust the valve opening speed.

ART 6100 Installation

- Installation of Albion ART 6100 should only be undertaken by competent professionals;
- Confirm that the product size and pressure meet the design requirement before installation commences;
- Ensure that the flow direction matches the flow direction arrow on the valve;
- Ensure that the pipework system has been flushed to remove any debris prior to installation;
- Sizes up to and including DN 100 can be installed either horizontally or vertically. Sizes DN 125 and above to be installed horizontally only;
- Ensure that sufficient space is available both upstream and downstream of the valve to allow suitable maintenance;
- Ensure the valve is in an open position prior to commissioning the valve;
- Ensure that the float is over 1.5 m away from the valve outlet;
- Regular maintenance of the particulate strainer is required to prevent blockages;
- If there is chance for the water to be turbulent the float must be adequately protected.
- It is recommended to use a sleeve to protect the float when in operation.
- It is always recommended water discharge happens inside the tank at a level that is below the level of the float pilot
- The pipe connecting the Pilot and the main valve shall be copper / stainless steel / polypropylene etc and sizes recommended are: -
 - 1” DN 50 – DN 150
 - 1 1/2” DN200 – DN300
- The minimum distance of valve and pilot shall be 1.5m and the maximum distance 10m.
- For the main valve to open there should be a minimum inlet pressure of 0.80 bar.

ART 6100 Repair Instruction

Main valve will not close

Failure Mode	Repair Method
Float ball is too close to the valve	Move the float ball further away from the valve or add the protective cover for the protection
Sealing position leakage	Tighten the nut or change the sealing parts
Needle valve doesn't work	Open the needle valve (anticlockwise) and flush the seat and clean any debris. Close the valve to the original position after 5 seconds
Main valve diaphragm broken	Change the diaphragm



Debris accumulated under the bottom of main valve	Disassemble, clean, check and change the damaged parts
Seat leakage	Replace seal
Joint leakage between the SS connection parts	Tighten the nut or change SS part

Main Valve will not open

Failure Mode	Repair Method
Needle valve open too much	Close the needle valve fully, then slowly open the needle valve until the outlet water flows
Ball valve closed	Open the ball valve
Float valve blocked	Disassemble, clean and check the float valve

Working Principles

Main valve: -

The float valve and pilot valve are connected by a stainless steel pipe etc. When the water level drops in the tank the float ball drops and the water in the main valve chamber discharges through the float pilot and thus the float valve opens to start discharge water to the tank.

The force of the upper chamber decreases, and the water inlet pressure pushes the disc to open the main valve which then allows water to flow. When the water level goes up, the float ball forces the valve to close, water comes in the main valve upper chamber until the pressure equal to the inlet pressure this then closes the main valve as the upper chamber force is bigger than the seat force.

Float Control Valve Installation Layout

Main Valve Part List

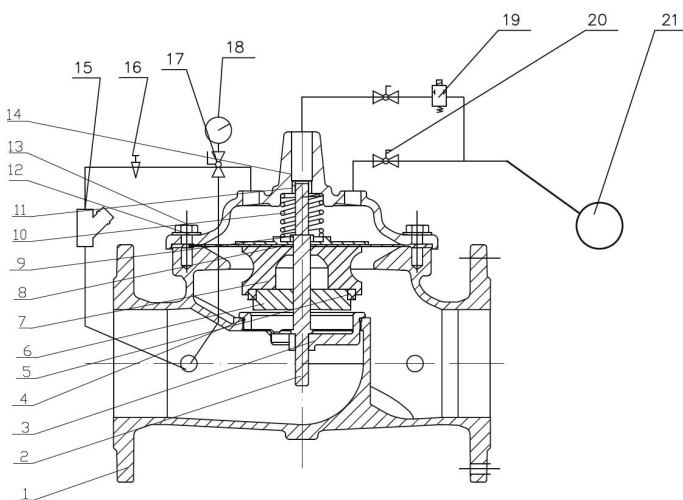
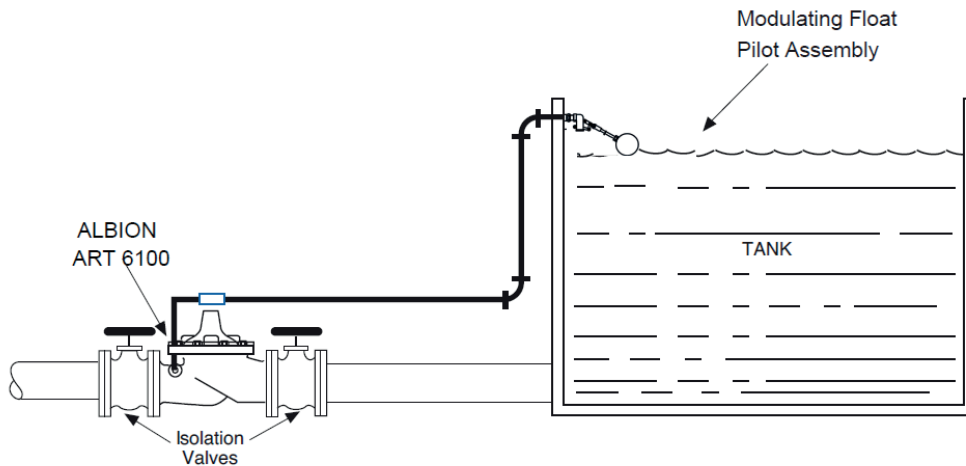

N.	Part Name	Materials
1	Body	Ductile Iron
2	Stem	Stainless Steel 304
3	Seat	Stainless Steel 304
4	O-Ring	NBR
5	Disc Ring	NBR
6	Disc Retainer	Ductile Iron
7	Disc Guide	Ductile Iron
8	Diaphragm	EPDM
9	Diaphragm Washer	Ductile Iron
10	Spring	Stainless Steel 304
11	Cover Bearing	Stainless Steel 304
12	Screw	Stainless Steel 304
13	Washer	Stainless Steel 304
14	Cover	Ductile Iron
15	Strainer	Stainless Steel 304
16	Needle Valve	Stainless Steel 304
17	Ball Valve	Stainless Steel 304
18	Pressure Gauge	Stainless Steel 304 (Glycerin Filled)
19	Solenoid Valve	Brass
20	Ball Valve	Stainless Steel 304
21	Float Control Valve	Stainless Steel 304



About Albion Valves (UK) Ltd

Albion has been supplying valves and fittings to the building services and industrial markets for the past 40 years.

Albion was created with the sole purpose of providing quality products at an affordable price. With a growing reputation for quality and reliability, Albion is now an established brand providing the industry with a trusted alternative to premium-priced products.

Our commitment to setting the highest standards in all areas of our business means, if you're looking for quality, service, delivery and choice — you'll find it's all at Albion.

Quality

Whatever you need, you can rest assured that if it comes from Albion it has been designed and manufactured to deliver optimum performance and is accredited with the necessary approvals. Our in-house quality department are always on hand too!

Service

We pride ourselves on our customer service – we have even won awards for it! Our cradle to grave approach means you will never be on your own!

Delivery

We know that time is money, and when a priority project depends on a part you can trust Albion to deliver – next day for all orders placed before 4:00PM.

Choice

We may have started out with a single brass ball valve, but our range has grown substantially since and we now consider ourselves to be a 'One Stop Shop' with our comprehensive range. It is becoming more and more apparent to the industry, that it really is all at Albion.