

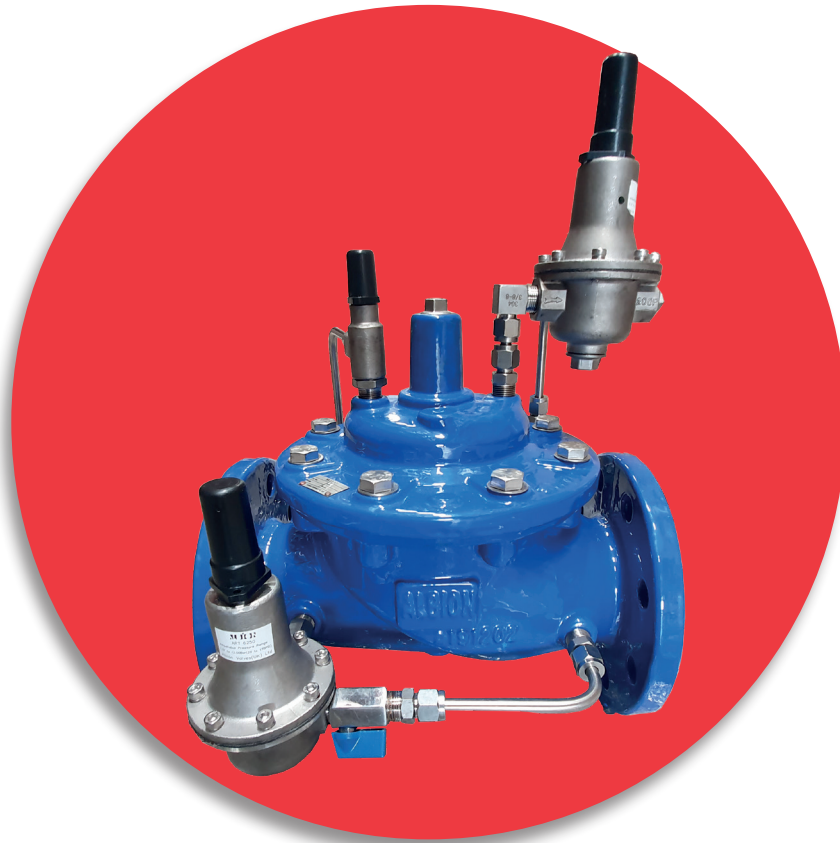

Installation & Operating Manual



ART 6800 Adjustable Pressure Reducing Valve with Low Flow Bypass

Albion Valves (UK) Ltd
www.albionvalvesuk.com
Email: sales@albionvalvesuk.com
Tel: 01226 729900



ART 6800 Function

Albion Valves (UK) Ltd ART 6800 Adjustable Pressure Reducing Valve is used to automatically reduce a higher upstream pressure to a lower downstream pressure regardless of any variance in flow rates.

The low flow bypass valve operates independently of the main pressure reducing valve dependent upon demand.

- Ball Valve
 - o The main function is to shut off the water between the pipe system and pilot control pipe system.
- Pilot Valve
 - o The main function is to adjust the outlet pressure.
- Needle Valve
 - o The main function is to adjust the valve opening speed.

ART 6800 Installation

- Any adjustments to ART 6800 should be made slowly thus allowing the valve to respond and the installation to become stable;
- Installation of Albion ART 6800 should only be undertaken by competent professionals;
- Confirm that the product size and pressure meet the design requirement before installation commences;
- Ensure that the flow direction matches the flow direction arrow on the valve;
- Ensure that the pipework system has been flushed to remove any debris prior to installation;
- Sizes up to and including DN 100 can be installed either horizontally or vertically. Sizes DN 125 and above to be installed horizontally only;
- Ensure that sufficient space is available both upstream and downstream of the valve to allow suitable maintenance;
- Ensure the valve is in an open position prior to commissioning the valve;
- Isolation valves should be installed both upstream and downstream of the ART 6200.
- For the main valve to open there should be a minimum inlet pressure of 0.80 bar.

ART 6800 Start Up Procedure

- Close upstream and downstream valves to isolate the valve from line pressure. Release spring tension on Pressure Reducing Control Valve by turning adjustment screw anti-clockwise. Open all Isolation Ball Valves, if so equipped. If valve is fitted with adjustable speed controls, turn needle(s) in (clockwise) until seated, and return out (anti-clockwise) 1 1/2 to 2 1/2 turns. These are approximate settings, and should be further adjusted to suit system requirements after pressure adjustments have been made.
- Slowly open upstream isolation valve to allow controlled filling of the valve. Vent air by loosening control tubing or pipe plug at the highest point possible. If valve is equipped with a Position Indicator, open the air bleed to vent air. Carefully loosen enough cover screws on control pilot(s) to vent entrapped air. Retighten when water vents clearly.



- Setting Reducing Control - slowly open downstream isolation valve. Gradually turn adjustment screw on the Pressure Reducing Control Valve to raise downstream pressure. Allow valve and system to stabilize. Observe inlet and outlet pressure gauges. Continue to adjust as needed, pausing approximately every 1 1/2 turns, allowing valve and system to stabilize. Turn the adjustment screw clockwise raises outlet pressure. Turning adjustment screw anti - clockwise lowers outlet pressure. When desired downstream pressure is reached, tighten locknut on adjustment screw.
- Fine tune Speed Controls to suit system requirements. Adjust Closing Speed Control (if equipped) clockwise for slower closure, and counterclockwise for faster closure. Adjust Opening Speed Control (if equipped) clockwise for slower opening, and counterclockwise for faster opening.
- Setting low flow bypass - turn adjustment screw on Low Flow By-Pass in (clockwise) to raise downstream pressure. Observe outlet pressure gauge. Continue to adjust Low Flow By-Pass, pausing approximately every 1 1/2 turns, allowing valve and system to stabilize, until desired downstream pressure is reached. Low Flow By-Pass is now set approximately 10 PSI higher than the Main Pressure Reducing Valve, and will handle low flow requirements. Tighten locknut on Low Flow By-Pass Pilot.

ART 6800 Repair Instruction

Main valve will not close

Failure Mode	Repair Method
Pilot valve setting too high	Slowly adjust the pilot valve anticlockwise
Sealing position leakage	Tighten the nut or change the sealing parts
Needle valve doesn't work	Open the needle valve(anticlockwise) and flush the valve
Main valve diaphragm broken	Change the diaphragm
Excess debris accumulation	Disassemble, clean the valve. Replace any damaged parts
Seat leakage	Replace the seal
Joint leakage between SS connection components	Tighten the nut or change SS part

Main Valve will not open

Failure Mode	Repair Method
Oversize valve	Use the bypass valve to achieve pressure reducing control
Needle doesn't work	Slowly adjust the needle valve clockwise till to the setting pressure

Pilot valve damage	Replace the pilot valve
--------------------	-------------------------

Pressure Reducing Valve

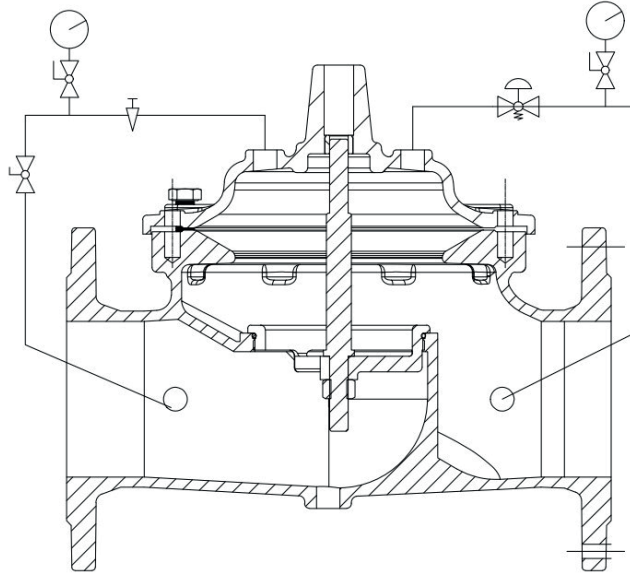

Main Valve Part List

N.	Part Name	Materials
1	Body	Ductile Iron
2	Stem	Stainless Steel 304
3	Seat	Stainless Steel 304
4	O-Ring	NBR
5	Disc Ring	NBR
6	Disc Retainer	Ductile Iron
7	Disc Guide	Ductile Iron
8	Diaphragm	EPDM
9	Diaphragm Washer	Ductile Iron
10	Spring	Stainless Steel 304
11	Cover Bearing	Stainless Steel 304
12	Screw	Stainless Steel 304
13	Washer	Stainless Steel 304
14	Cover	Ductile Iron
15	Strainer	Stainless Steel 304
16	Needle Valve	Stainless Steel 304
17	Pilot Valve	Stainless Steel 304
18	Ball Valve	Stainless Steel 304
19	Low Bypass Pilot Valve	Stainless Steel 304

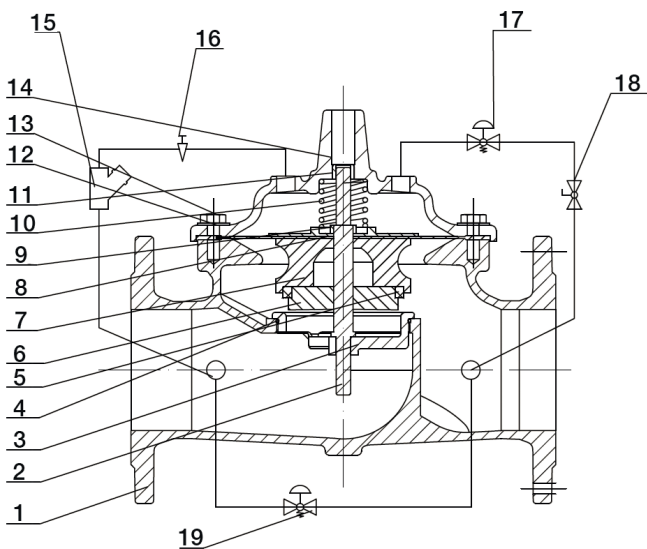



About Albion Valves (UK) Ltd

Albion has been supplying valves and fittings to the building services and industrial markets for the past 40 years.

Albion was created with the sole purpose of providing quality products at an affordable price. With a growing reputation for quality and reliability, Albion is now an established brand providing the industry with a trusted alternative to premium-priced products.

Our commitment to setting the highest standards in all areas of our business means, if you're looking for quality, service, delivery and choice — you'll find it's all at Albion.

Quality

Whatever you need, you can rest assured that if it comes from Albion it has been designed and manufactured to deliver optimum performance and is accredited with the necessary approvals. Our in-house quality department are always on hand too!

Service

We pride ourselves on our customer service – we have even won awards for it! Our cradle to grave approach means you will never be on your own!

Delivery

We know that time is money, and when a priority project depends on a part you can trust Albion to deliver – next day for all orders placed before 4:00PM.

Choice

We may have started out with a single brass ball valve, but our range has grown substantially since and we now consider ourselves to be a 'One Stop Shop' with our comprehensive range. It is becoming more and more apparent to the industry, that it really is all at Albion.